

ROTAX[®]
KARTING

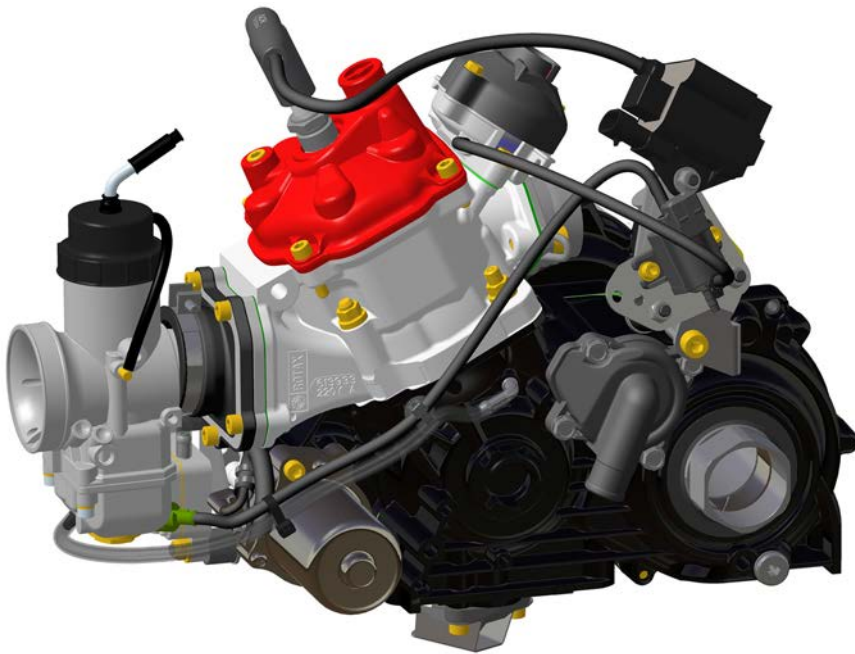

Installation instructions and Operator's Manual



for ROTAX[®]-engines type

125 MAX DD2 evo

Part no.: 297733

Edition: 10/2019

General information

BRP-Rotax recommends products of the following companies:



For information regarding the repair of the engine 125 MAX DD2 evo contact an authorized service center or consult the workshop manual (available on the internet at www.rotax-kart.com).

We ask to hand over this manual, the engine identity card and the product and service registration document to the new owner in case of a change of ownership.

Preface

This document and all technical data and procedures therein are property of BRP-Rotax GmbH & Co KG and based on the state of knowledge at the time of publication. The manual has been drawn up to the best of our knowledge. However, we exclude any liability.

We reserve all rights including technical modification and possibility of errors. Reprinting, translation or copies in whole or in part, are authorized only after written permission by BRP-Rotax GmbH & Co KG.

BRP-Rotax GmbH & Co KG reserves the right at any time to discontinue or change specifications, prices, designs, features, models or equipment without incurring any obligations.

Engine performance may vary depending on, among other things, general conditions, ambient temperature and altitude.

BRP-Rotax
INSTALLATION MANUAL

Table of Content

Chapter	INTRO –
Chapter	1 – Engine installation
Chapter	2 – Fuel system
Chapter	3 – Electric system
Chapter	4 – Cooling system
Chapter	5 – Exhaust system
Chapter	6 – Installation of the accessories
Chapter	7 – Finishing work

BRP-Rotax
INSTALLATION MANUAL

NOTES

BRP-Rotax INSTALLATION MANUAL

Chapter: INTRO

Preface

For information regarding repair of the engine 125 MAX DD2 evo contact an authorized service center or consult the workshop manual (available on internet under www.rotax-kart.com).

We ask to hand over this manual, the engine identity card and the product and service registration document to the new owner in case of a change of ownership.

Contents

This Installation Manual contains instructions for all the installation work on the ROTAX®-Engine Type 125 MAX DD2 evo.

General

This document and all technical data and procedures therein are property of BRP-Rotax GmbH & Co KG and based on the state of knowledge at the time of publication The Manual has been drawn up to the best of our knowledge. However, excluding any liability.

We reserve all rights including technical modification and possibility of errors. Reprinting, translation or copies in whole or in part, are authorized only after written permission by BRP-Rotax GmbH & Co KG.

BRP-Rotax GmbH & Co KG reserves the right at any time to discontinue or change specifications, prices, designs, features, models or equipment without incurring obligation. Engine performance may vary depending on, among other things, general conditions, ambient temperature and altitude.

NOTE

The registration document and engine identity card must be provided to the final consumer upon delivery by the authorized service center with handover date and company stamp.

NOTE

The data entered in the registration document and/or engine identity card is required for the verification of a warranty claim. Without a completely filled-in engine identity card, no warranty claim will be granted.

NOTE

In case of participating in the ROTAX® MAX CHALLENGE (RMC) the engine must be verified for conformity with the technical regulations and sealed. The serial number of the seal must be entered in the engine identity card.

BRP-Rotax INSTALLATION MANUAL

Symbols used

This Manual uses the following symbols to emphasize particular information. This information is important and must be observed.

⚠ WARNING
Identifies an instruction, which if not followed may cause injury or endanger the life of the driver, mechanic or third party.

ATTENTION
Identifies an instruction which, if not followed may cause injury or endanger the life of the driver, mechanic or third party.

ENVIRONMENTAL NOTE
Environmental notes give you tips on environmental protection.

NOTE

Indicates supplementary information which may be needed to fully complete or understand an instruction.

✓ Denotes a checking operation

TIP This information gives you additional advice and tips

BRP-Rotax INSTALLATION MANUAL

Safety information

⚠ WARNING

Non-compliance can result in serious injuries or death!

For the best possible engine operation, compliance with the following advice regarding installation of engine and equipment is required.

⚠ WARNING

Non-compliance can result in serious injuries or death!

Engine operation is permitted only with equipment supplied by ROTAX®

⚠ WARNING

Non-compliance can result in serious injuries or death!

Besides the engine-specific installation advice, also take note of information from the respective chassis manufacturer.

Introduction

Congratulations on choosing the ROTAX engine Type 125 MAX DD2 evo. The ROTAX® engine Type 125 MAX DD2 evo has been developed exclusively for use in Go-karts, which must only be run on specified tracks. This product has numerous technical innovations.

⚠ WARNING

Non-compliance can result in serious injuries or death!

Before starting with installation and operation of the engine, observe the installation instructions and Operator's Manual and follow all instructions.

⚠ WARNING

Non-compliance can result in serious injuries or death!

This engine performs better as comparable products

BRP-Rotax INSTALLATION MANUAL

UNBOXING AND PURCHASED PARTS PACKAGE

By buying a ROTAX Engine, you will receive two boxes. The engine box and the accessory box.



Figure 1.1: Unboxing

Engine box

The engine box contains the pre-assembled engine with the secure sticker, which describes the run-in procedure. Take the engine out of the box.

Accessory box

The accessory box contains all required parts for running the engine. Lay down all parts, so you have a good overview of the parts. Check, if all parts of the following table are delivered.

BRP-Rotax INSTALLATION MANUAL



KA_125_0320

Figure 1.2: Accessory box

Pos.	Description	Check mark
1	Radiator with coolant hoses	○
2	Mounting plate with ignition coil, solenoid valve and spark plug cap	○
3	Battery box and wiring harness	○
4	Battery charger	○
5	Intake silencer	○
6	Fuel pump with fuel hose	○
7	Exhaust system	○
8	Manuals and engine identity card	○
9	Several small parts (spark plug, screws,...)	○
10	Hose package for RAVE control unit	○
11	ECU	○
12	Carburetor	○
13	Paddle shift system	○

BRP-Rotax
INSTALLATION MANUAL

ENGINE INFORMATION

Engine serial number

The engine serial number is stamped on the clutch side housing-half.

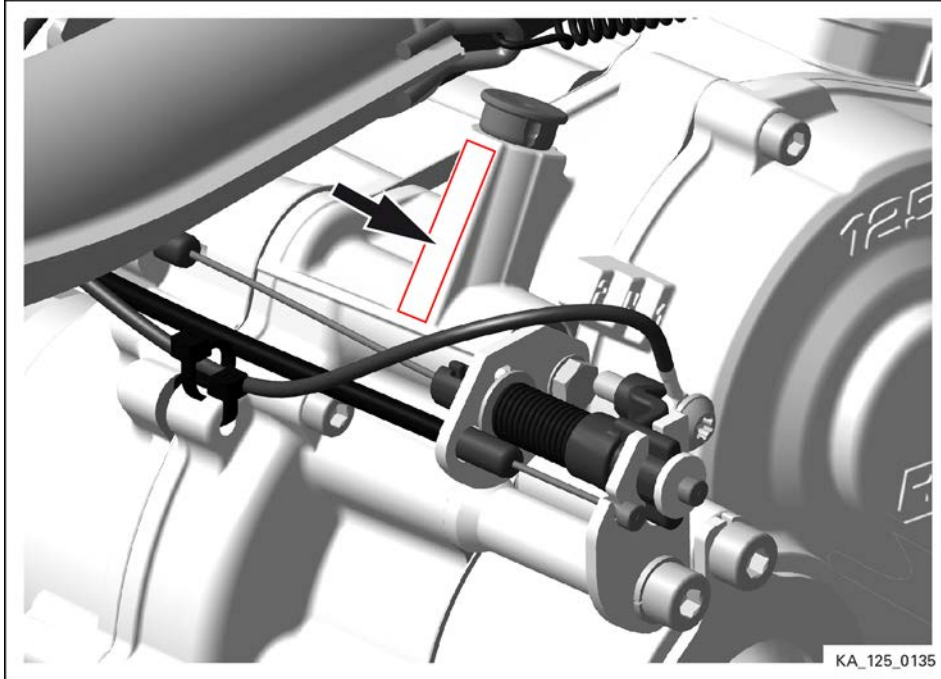

Figure 1.3: Serial number of the engine, TYPICAL

BRP-Rotax
INSTALLATION MANUAL

Gear oil and fuel specifications

See the latest Operators Manual.

Equipment and modifications

Modifications to engine and/or equipment are not allowed.

BRP-Rotax
INSTALLATION MANUAL

NOTES

BRP-Rotax
INSTALLATION MANUAL

Chapter: 1
ENGINE INSTALLATION

TOPICS IN THIS CHAPTER

Installation of overload clutch and engine with rear axle2
Engine installation with engine brackets3
Direct attachment of the engine to chassis.....5

BRP-Rotax INSTALLATION MANUAL

INSTALLATION OF OVERLOAD CLUTCH AND ENGINE WITH REAR AXLE

NOTE

The overload clutch is the link between the engine and the rear axle of the kart. In case that the rear axle has been blocked by (e.g. braking), the overload clutch is slipping slightly and is not transferring the peak load from the rear axle to the engine.

The plain bearings (pos. 2) are inside of the overload clutch (pos. 1).

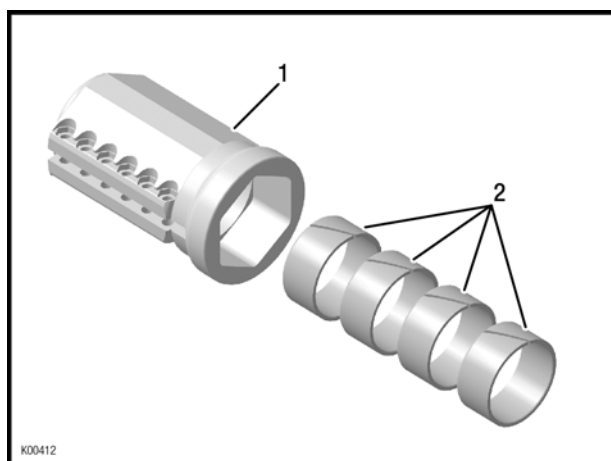

Figure 2.1

- 1 Overload clutch 2 Plain bearings

Step	Procedure
1	Slide the clamp ring (pos. 1, following figure) the thrust washer (pos. 2) and the overload clutch (3) to the middle of the rear axle.

NOTE

The rear axle of the kart must have a smooth surface (no grooves for keys) in the area of the 4 plain bearings of the overload clutch.

NOTE

Do not tighten the overload clutch and clamp ring yet (see section Engine attachment with engine brackets).

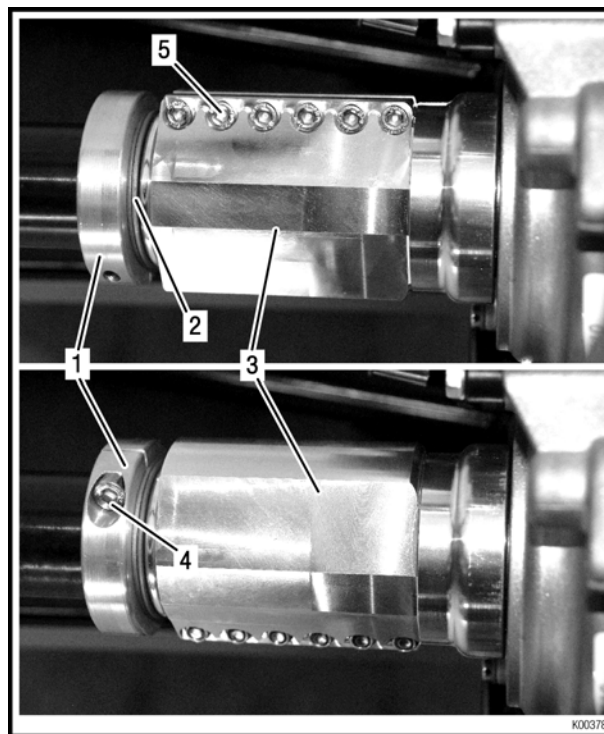

Figure 2.2: Overload clutch

- 1 Clamping ring 2 Thrust washer
3 Overload clutch 4 Allen screw M6x25
5 Allen screw M5x30

BRP-Rotax INSTALLATION MANUAL

ENGINE INSTALLATION WITH ENGINE BRACKETS

Tools required:

- Allen key 8mm
- Allen key 5 mm
- Allen key 4 mm
- Torque wrench

See Figure: Tightening sequence and Engine brackets.

The engine has to be fixed to the chassis by means of 2 engine brackets (pos. 1). Due to different distances of the 2 main rails of various chassis brands, the engine bracket is not included in the scope of supply.

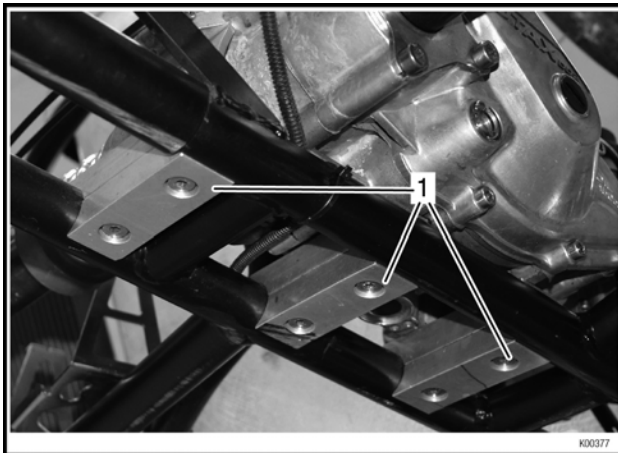

Figure 2.3: Engine brackets

FIGURE SIMILAR

NOTE

The 125 MAX DD2 engine can only be mounted on specially prepared chassis for this engine type.

⚠ WARNING

**Non-compliance can result in serious injuries
or death!**

For engine attachment to the chassis, please follow the instruction of the chassis manufacturer.

Step	Procedure
1	Slide the engine onto the rear axle and align the rear axle and the engine by measuring the distance between the front and the rear axle
2	After engine alignment, tighten the 4 Allen screws M8 x 25 to fix the upper engine bracket to the engine with 28 Nm (20.65 ft. lb). Fix and tighten the lower engine bracket to the upper bracket with 4 Allen screws M8 x 30 with 22 Nm (16.22 ft. lb). Secure the Allen screws with LOCTITE 243 blue.

NOTE

The minimum screw in length of the screws fixing the engine brackets onto the crankcase is 16 mm to 20 mm (0.6 - 0.95 in.).

Step	Procedure
3	Slide the overload clutch, thrust washer and clamp ring along the axle to the hollow shaft and then fix to the rear axle. Tighten the screw on the clamping ring with 10 Nm (89 in. lb).
4	Tighten the 6 Allen screws (pos. 1, Figure Tightening sequence) on the overload clutch with 7 - 8 Nm (62 - 71 in. lb). Make sure that every screw is tightened with the right tightening torque, repeat procedure if necessary.

BRP-Rotax INSTALLATION MANUAL

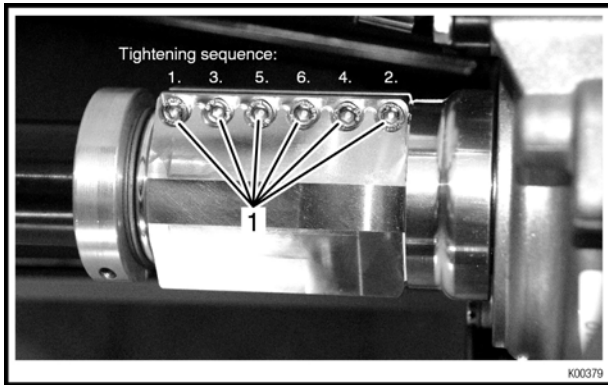

Figure 2.4: Tightening sequence

1 *Allen screws*

BRP-Rotax INSTALLATION MANUAL

DIRECT ATTACHMENT OF THE ENGINE TO CHASSIS

If the frame of the chassis is specially prepared for installation of the ROTAX® 125 MAX DD2 evo, then 2 sheet metal brackets with holes are welded onto the two frame tubes. The engine is clamped between the two brackets with 4 bolts.

NOTE

The minimum screw in length of the screws fixing the engine brackets onto the crankcase is 16 mm to 20 mm (0.6 - 0.95 in.).

NOTE

Secure bolts with bolt adhesive e.g. LOCTITE 243.

Step	Procedure
1	Mount engine directly on the brackets.

NOTE

Check for easy access to the pick-up sensor (pos. 1). There are two options to install the pick-up sensor. Choose the orientation which gives you the best fit for your chassis installation.

⚠ WARNING

Non-compliance can result in serious injuries or death!

For engine attachment to the chassis, please follow the instruction of the chassis manufacturer.

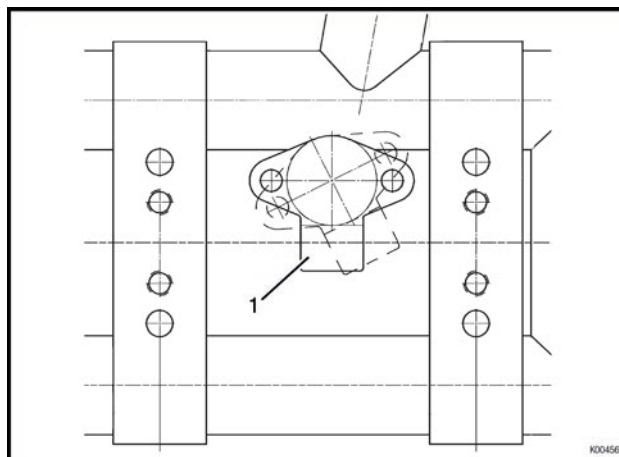

Figure 2.5

1 Pick-up sensor

BRP-Rotax
INSTALLATION MANUAL

NOTES

BRP-Rotax
INSTALLATION MANUAL

Chapter: 2
FUEL SYSTEM

TOPICS IN THIS CHAPTER

Installation and connection of the fuel pump.....	2
Installation of the Bowden cable for carburetor control.....	4
Installation and connection of the carburetor.....	6

BRP-Rotax INSTALLATION MANUAL

INSTALLATION AND CONNECTION OF THE FUEL PUMP

Tools required:

- Allen key 5 mm
- Circlip pliers

Step	Procedure
1	The retaining plate, rubber buffers, fuel pump, fuel hose (with 230 mm and 1800 mm length) is already pre-assembled.

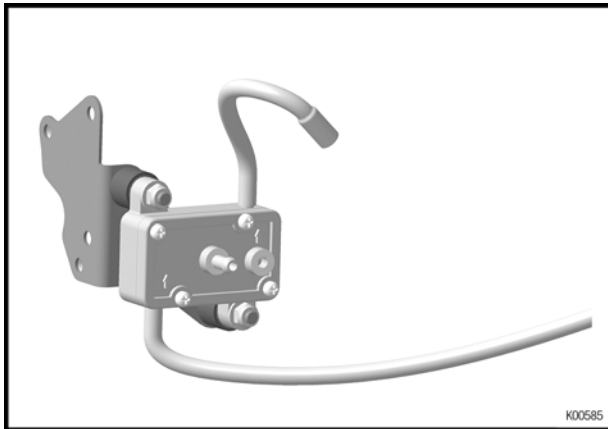

Figure 3.1

Step	Procedure
2	Install the retaining plate with fuel pump (pos. 1) on the gearbox cover by using 2 screws M6x30 (pos. 3) and washers (pos. 2).

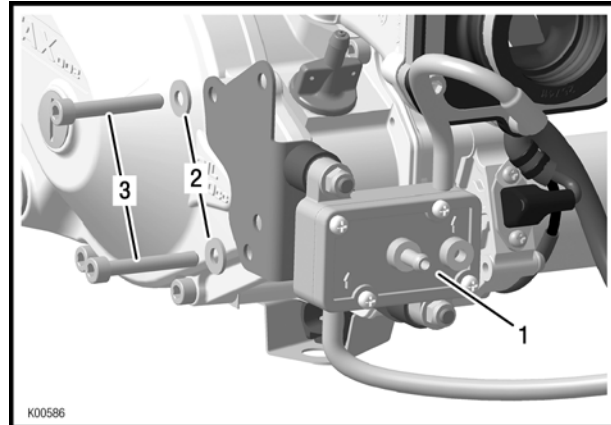

Figure 3.2

- 1 Fuel pump 2 Washer
3 Screws M6x30



Figure 3.3

TIP Facilitate the assembly of fuel hose by slightly widening the hose end with a pair of circlip pliers.

ATTENTION

Fuel hose can be damaged!
Avoid excessive widening of the fuel hose.

BRP-Rotax INSTALLATION MANUAL

Step	Procedure
3	The fuel hose with 230 mm length will be connected later to the carburetor, see carburetor installation.
4	The larger fuel hose (pos. 1) should be connected to the fuel filter (pos. 2) and to the fuel tank.

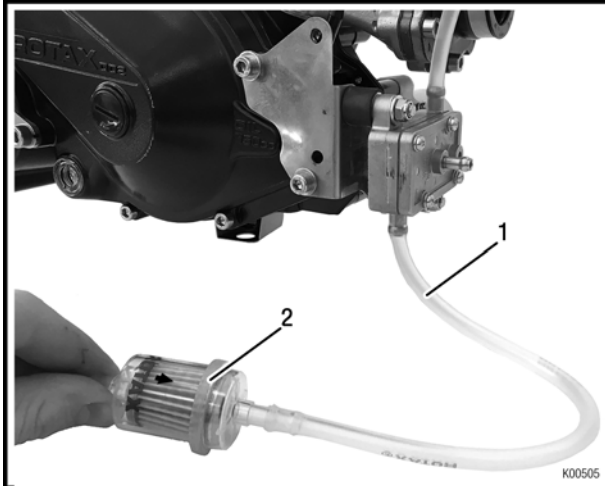

Figure 3.4

1 Large fuel hose 2 Fuel filter

ATTENTION

Pay attention to the direction of the arrow on the fuel filter.

This must point towards the fuel pump.

ATTENTION

Route the fuel line from the fuel tank to the fuel filter so that it does not touch any moving parts of the track and attach the fuel line onto the top side of the chassis tube.

ATTENTION

The flow in the impulse hose and fuel lines must not be restricted by the use of cable ties.

BRP-Rotax INSTALLATION MANUAL

INSTALLATION OF THE BOWDEN CABLE FOR CARBURETOR CONTROL

Tools required:

- Open-end wrench 10 mm

Step	Procedure
1	Carefully remove carburetor cover with rubber ring (pos. 7, 8).

ATTENTION

Reset spring of carb piston presses against carburetor cover and might eject carburetor cover at removal.

Step	Procedure
2	Remove nipple screw (pos. 5) with open-end wrench 10 mm from carburetor piston (pos. 2).
3	Engage nipple of Bowden wire (pos. 9) in nipple screw (pos. 5).
4	Fit nipple screw in carburetor piston and hand tighten with open-end wrench 10 mm.
5	Insert carburetor piston (pos. 2) into carb body with recess of piston towards intake silencer.
6	Pass Bowden wire through compression spring (pos. 6) and through cover with rubber ring (pos. 7, 8) of carburetor.
7	Fit carb cover (pos. 7) on carburetor.
8	Pass Bowden wire through Bowden conduit and through adjustment screw on chassis (throttle pedal).
9	Connect Bowden cable to throttle pedal.

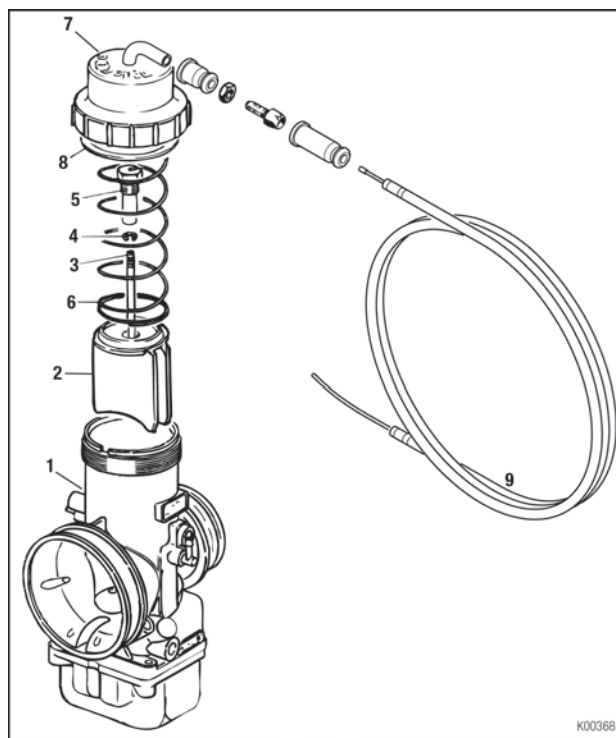

Figure 3.5

- | | |
|------------------|----------------------|
| 1 Carburetor | 2 Carburetor piston |
| 3 Jet needle K57 | 4 Clip |
| 5 Nipple screw | 6 Compression spring |
| 7 Carb cover | 8 Rubber ring |
| 9 Bowden cable | |

NOTE

Shorten Bowden cable as required.

Step	Procedure
10	Route carburetor Bowden cable on the top side of the chassis tubes and attach with the cable ties supplied. Make sure that the Bowden cable does not touch any moving parts or the track.

BRP-Rotax INSTALLATION MANUAL

WARNING

Non-compliance can result in serious injuries or death!

The carburetor Bowden cable must not be kinked or restricted as the carburetor piston might get stuck in full throttle position.

Step	Procedure
11	Set and secure the adjustment screw for Bowden cable on chassis so that the carburetor piston will remain in closed position when throttle pedal is not activated.
12	Set and secure the stop screw for throttle pedal so that, with pedal completely pressed down, the carburetor piston will be in the full open position. The Bowden cable must not be under full tension when the throttle is in fully open position.

BRP-Rotax
INSTALLATION MANUAL

INSTALLATION AND CONNECTION
OF THE CARBURETOR

Tools required:	
• Ratchet wrench with socket 7 mm	
• Phillips screwdriver	

Step	Procedure
1	Fit carburetor (pos. 1) into carburetor socket and secure with hose clamp (pos. 2) in vertical position.
2	Connect the outlet hose of the fuel pump with fuel inlet (pos. 3) on the carburetor.

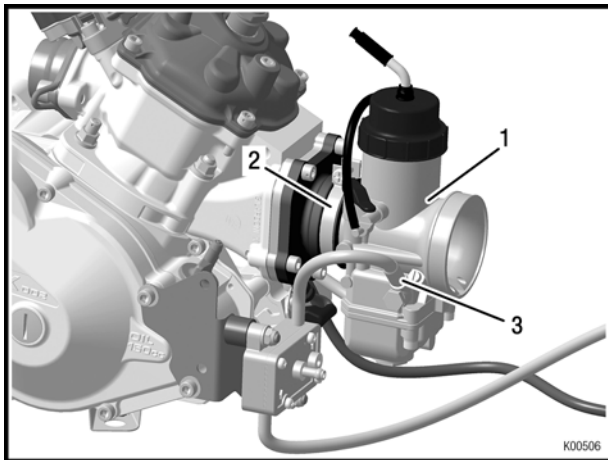

Figure 3.6

- 1 Carburetor 2 Hose clamp
3 Fuel inlet

BRP-Rotax
INSTALLATION MANUAL

Chapter: 3
ELECTRIC SYSTEM

TOPICS IN THIS CHAPTER

Electric system overview	2
Installation ECU into the battery clamp assy.....	3
Installation of the battery clamp assy.	5
Installation of the wiring harness	7

BRP-Rotax
INSTALLATION MANUAL

ELECTRIC SYSTEM OVERVIEW

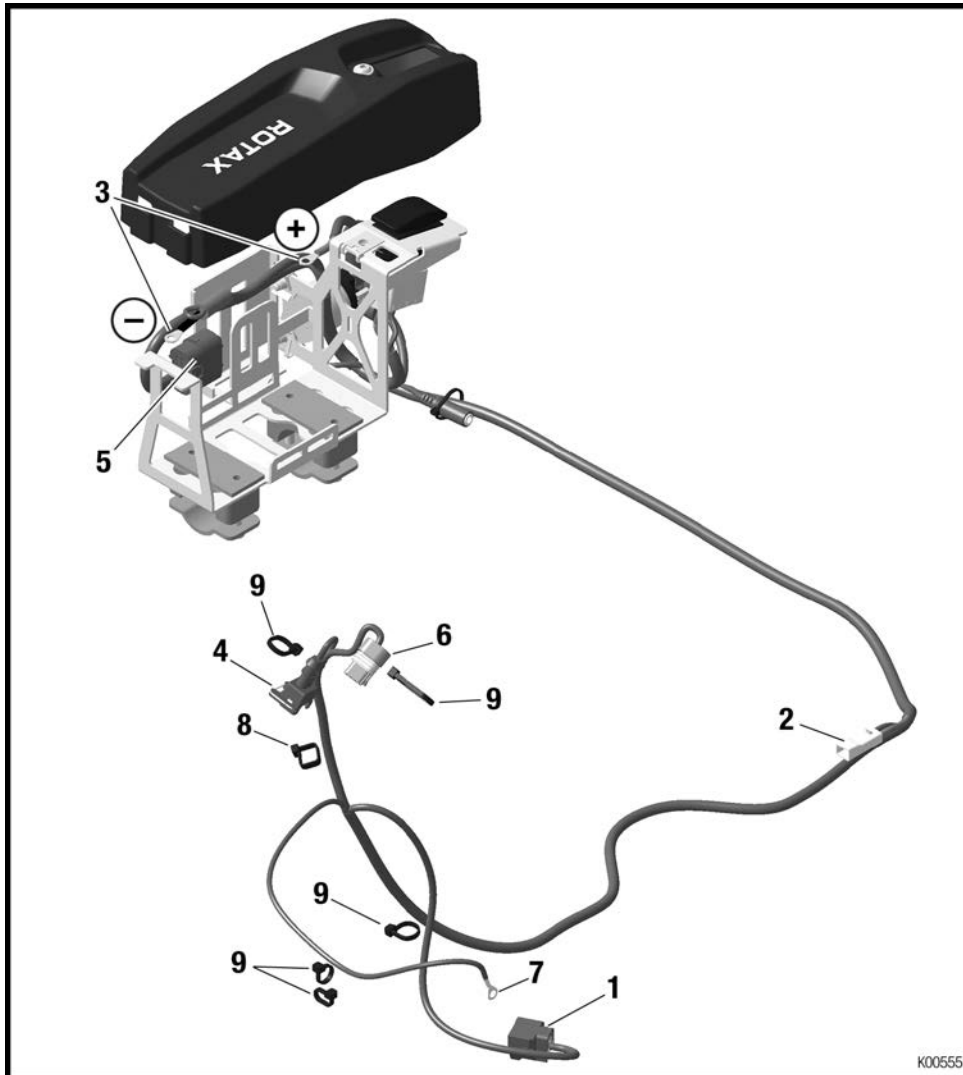

Figure 4.1

- | | |
|---------------------------|--|
| 1 Connector pickup sensor | 2 Connector starter |
| 3 Connector battery | 4 Connector RAVE (only applicable 125 MAX evo) |
| 5 Connector ECU | 6 Connector ignition coil |
| 7 Connector shift contact | 8 Tie wrap 250x4.8 |
| 9 Tie wrap 142x3.2 | |

BRP-Rotax INSTALLATION MANUAL

INSTALLATION ECU INTO THE BATTERY CLAMP ASSY.

Step	Procedure
1	Prepare rubber pad (consists of two halves) (pos. 1) and the ECU (pos. 2) for installation.

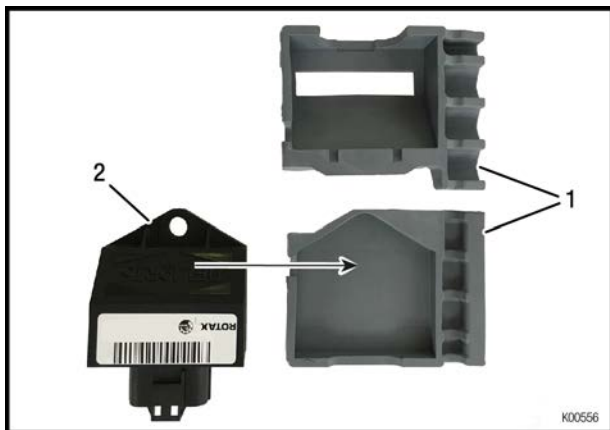

Figure 4.2

1 Rubber pad

2 ECU

Step	Procedure
2	Install the rubber pad (pos. 1) onto the ECU.

TIP Align at the triangular bottom of the ECU. It fits only in one position to the rubber pad.

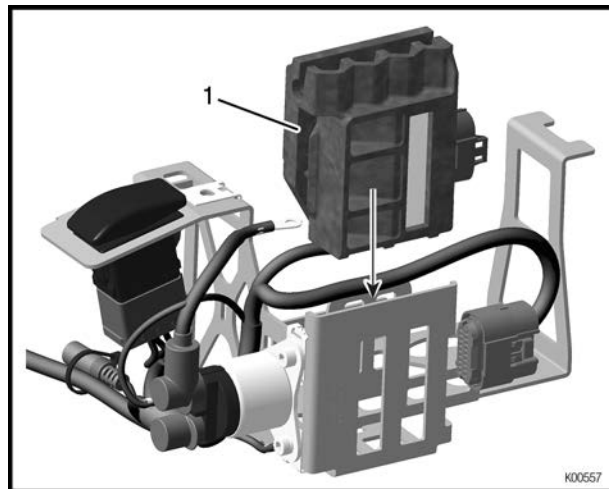

Figure 4.3

1 Rubber pad

Step	Procedure
3	Insert the complete unit into the battery clamp assy..

NOTE

If difficulties at insertion occur, the inside of the battery clamp assy. can be easily bent inward so that the distance increases slightly.

ATTENTION

Make sure that the connection cable has been installed between the two pads.

The connection of the ECU is on the rear side (against the driving direction).

BRP-Rotax INSTALLATION MANUAL

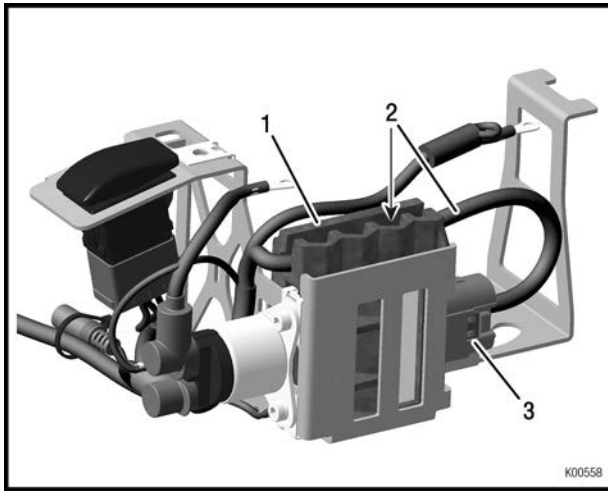

Figure 4.4

- | | | | |
|---|----------------------|---|-------------------------|
| 1 | <i>Rubber pad</i> | 2 | <i>Connection cable</i> |
| 3 | <i>ECU connector</i> | | |

BRP-Rotax INSTALLATION MANUAL

INSTALLATION OF THE BATTERY CLAMP ASSY.

Tools required:

- Allen key 4 mm
- Ratchet wrench with socket 8 mm or Phillips screwdriver

⚠ WARNING

Non-compliance can result in serious injuries or death!

Make absolutely sure to avoid short-circuiting of battery terminals. A short circuit will ruin the battery and could cause an explosion.

Step	Procedure
1	Attach the battery fixture (pos. 5) with the two pipe clamps (pos. 1 – 4) on the left side box beside the driver's seat.

NOTE

The clamps (pos. 2, 3) are designed for chassis tubes of 30 - 32 mm (1.18 – 1.26 in) diameter.

ATTENTION

Risk of clamp fracture!

Do not over tighten the screw of the pipe clamps.

Step	Procedure
2	Install rubber pad (pos. 6) with battery (pos. 7) into the battery holder (pos. 5).
3	Put the battery (pos. 7) into the fixture and install the cover (pos. 8) with pre-assembled wiring harness using the Allen screw with rounded flange head (pos. 9).

TIP The battery fixture (pos. 5) can be fixed with one screw on one side of the clamp (pos. 3).

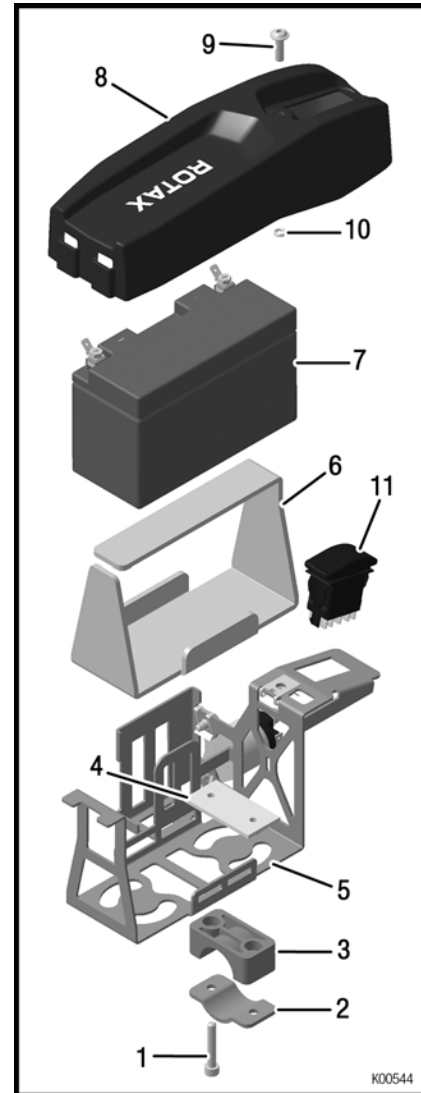

Figure 4.5

- | | |
|-----------------|-----------------------------|
| 1–4 Pipe clamps | 5 Battery fixture |
| 6 Rubber pad | 7 Battery |
| 8 Battery cover | 9 Flange head screw |
| 10 O-ring | 11 Multiple function switch |

BRP-Rotax INSTALLATION MANUAL

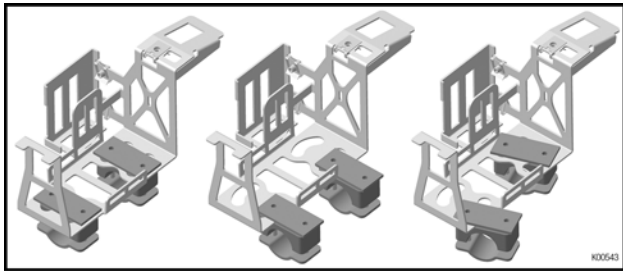

Figure 4.6

NOTE

The battery terminals must point in the direction of the control unit.

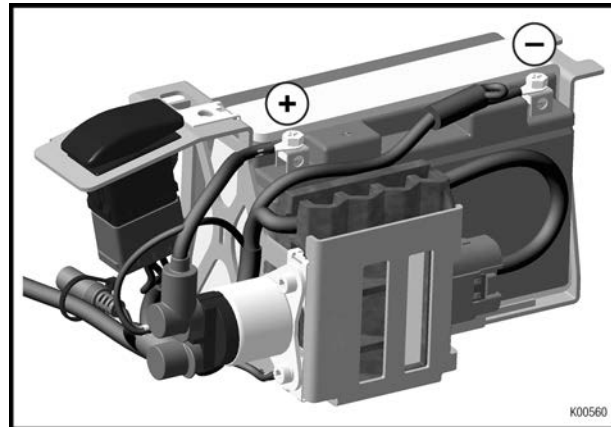

Figure 4.8

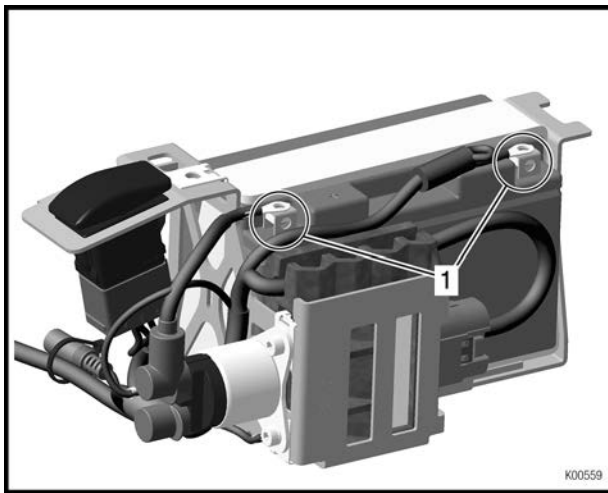

Figure 4.7

1 Battery terminals

Step	Procedure
5	Install the battery cover onto the battery holder.

NOTE

Make sure that the two retaining lugs (pos. 1) are in the notches of the battery cover!

Step	Procedure
6	Tighten flange head screw (pos. 2) of the battery cover.

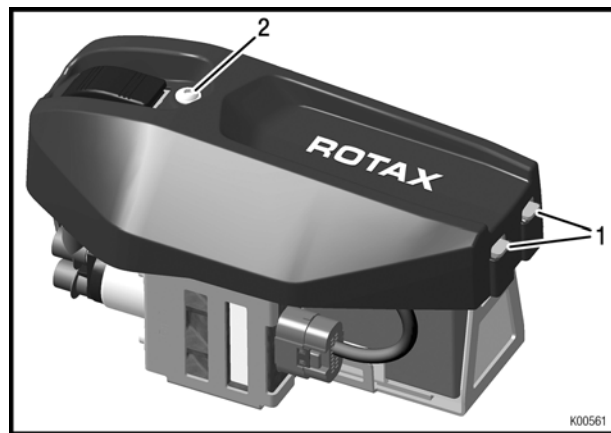

Figure 4.9

1 Retaining lugs

2 Flange head screw

Step	Procedure
3	Connect the positive terminal (red) of the battery.
4	Connect the negative terminal (black) of the battery.

BRP-Rotax INSTALLATION MANUAL

INSTALLATION OF THE WIRING HARNESS

Tools required:

- Torx screwdriver T30

The wiring harness is delivered partly pre-assembled to facilitate the installation. This means that the relay, the master switch and the battery cover are already pre-assembled and wired.

NOTE

The connector assignment is shown on the following pages. Details on the assignment of cables and pins are given in the wiring diagram.

NOTE

Cable lugs may break after repeated bending.

Step	Procedure
1	Place the wiring harness loosely on the chassis.

NOTE

Always start the installation at the engine side to work without tension on the wiring harness.

ATTENTION

Strain relief of the plug connections must be ensured.

NOTE

Compensate excessive length of wiring harness by routing cables in loops.

⚠ WARNING

Non-compliance can result in serious injuries or death!
The wiring harness must not touch moving parts of the track.

NOTE

When unplugging connections on ignition pick up and ignition coil, press the integrated catch first.

NOTE

Disconnect any electrical plug connection only by pulling on the plugs.

Step	Procedure
2	Pre-mount cable tie large through the two holes provided on the mounting plate.

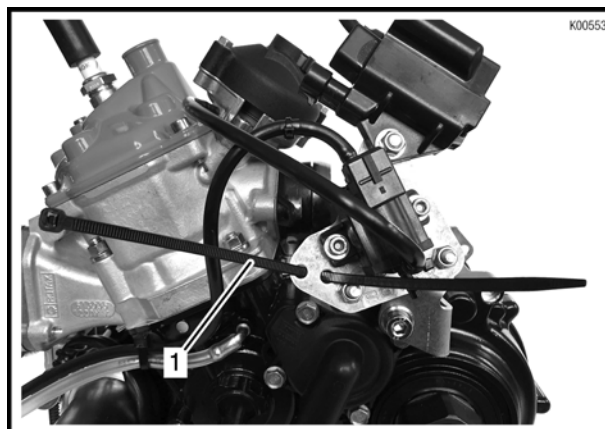

Figure 4.10: Installation

1 Cable tie

Step	Procedure
3	Connect solenoid valve and ignition coil. Attach both connectors (signed green) on the two components.
4	Fasten cables with cable ties on the mounting plate.

BRP-Rotax INSTALLATION MANUAL

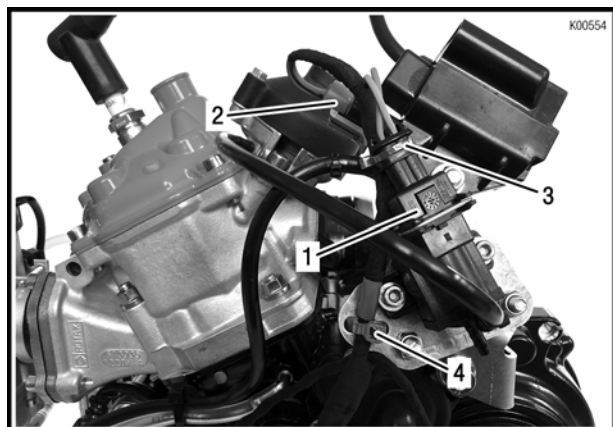

Figure 4.11

- 1 Solenoid valve 2 Ignition coil
- 3 Connectors (signed green) 4 Cable tie

Step	Procedure
5	Remove isolation tape from the shift contact wire (pos. 1) and loosely fasten with a tie wrap (pos. 2) (about 130 mm from the cable lug).

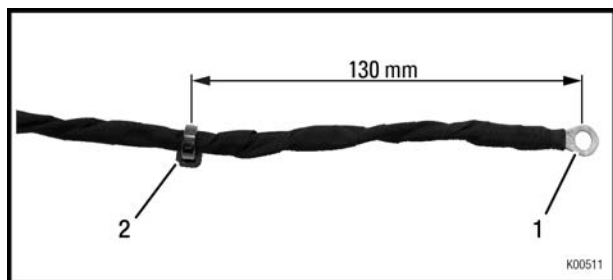

Figure 4.12

- 1 Contact wire 2 Tie wrap

NOTE

Do not tighten tie wrap yet in order to be able to change its position later on.

Step	Procedure
6	Fasten the cable lug (pos. 3) to the shift contact assy. using the Plastite screw M6x25 (pos. 4). Pay attention to correct sequence of the components! See following Figures. For correct adjusting of the plastite screw find the according section inside the latest Operators Manual.

NOTE

Fasten the cable lug (pos. 3) between the fuel tube 8 mm (pos. 2) and the Plastite screw M6x25 (pos. 4). See following Figure.

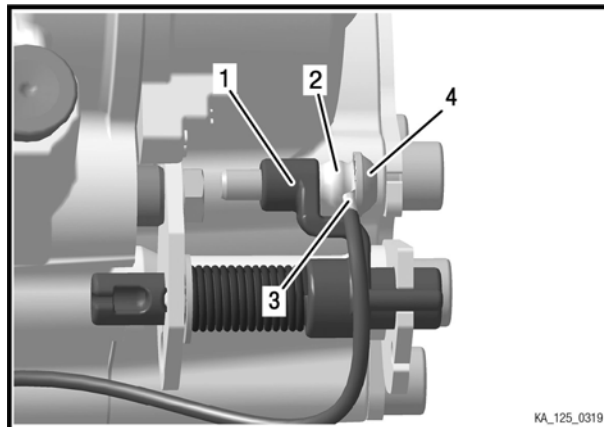

Figure 4.13

- 1 Shift contact assy. 2 Fuel tube
- 3 Cable lug 4 Plastite screw M6x25

NOTE

The correct adjustment of the shift contact is described in the Operators Manual, section "Adjustment of gear shifting".

Step	Procedure
7	Fasten the wire of the shift contact assy. with a tie wrap (pos. 1) on the bottom of the engine.

BRP-Rotax INSTALLATION MANUAL

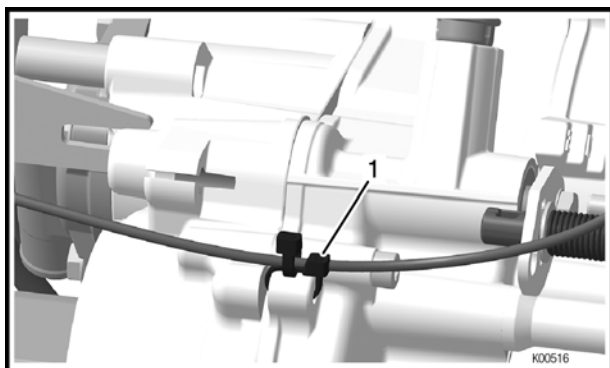

Figure 4.14

1 Tie wrap

Step	Procedure
9	Attach ignition cables to the spark plug.

Step	Procedure
8	Connect pick up connector to pick up sensor (pos. 1). Pay attention to the engagement of the connector. See also section: Direct attachment of the engine to chassis.

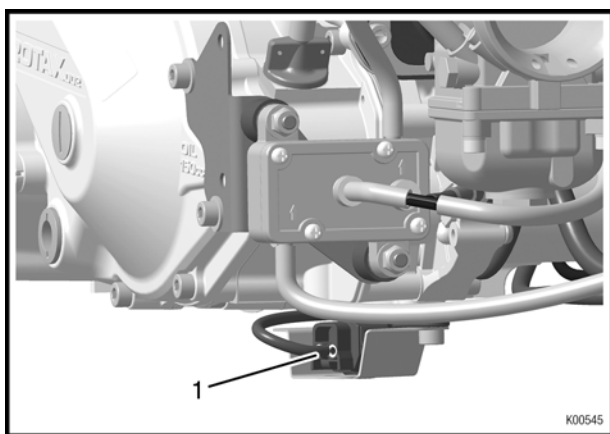

Figure 4.15

1 Pick up sensor

NOTE

If it's not possible to plug in the connector of the pick-up sensor, unscrew the pick-up sensor and change the angle or direction. See also section: Direct attachment of the engine to chassis.

BRP-Rotax
INSTALLATION MANUAL

NOTES

Notes

BRP-Rotax
INSTALLATION MANUAL

Chapter: 4
COOLING SYSTEM

TOPICS IN THIS CHAPTER

Cooling system overview	2
Installation of the radiator	3
Intake silencer	4
Installation of the intake silencer with integrated airfilter	5

BRP-Rotax
INSTALLATION MANUAL

COOLING SYSTEM OVERVIEW

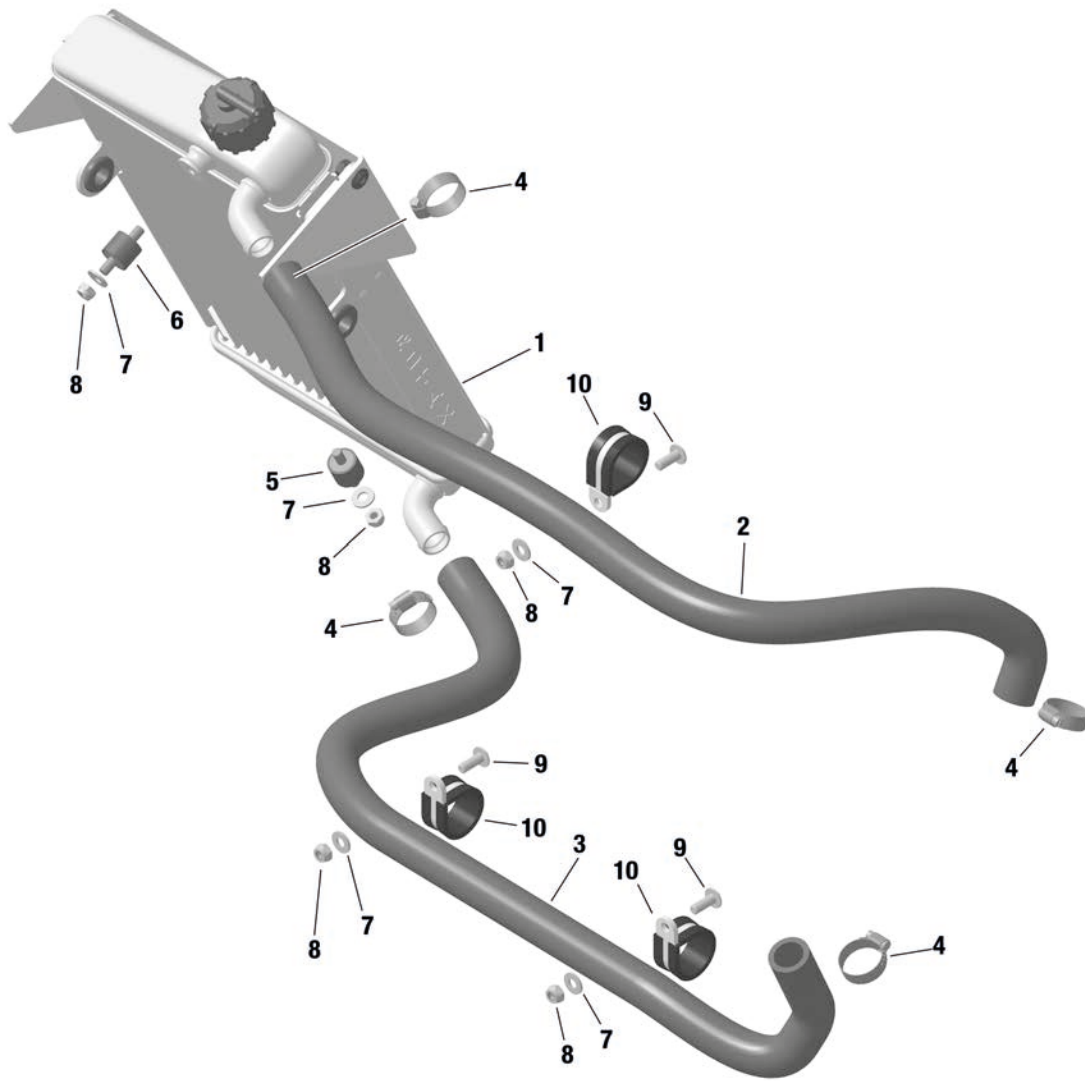

KA_125_0012

Figure 5.1

- | | |
|-------------------------------------|----------------------------|
| 1 Radiator | 2 Upper coolant water hose |
| 3 Lower coolant water hose | 4 Clamp 16–25 |
| 5 Rubber puffer | 6 Rubber puffer |
| 7 Washer | 8 Lock nut |
| 9 Allen screw — rounded flange head | 10 Hose clamps |

BRP-Rotax INSTALLATION MANUAL

INSTALLATION OF THE RADIATOR

Tools required:

- Ratchet wrench with socket 7 mm or Phillips screwdriver

Step	Procedure
1	Mount radiator (pos. 1) using the provided rubber buffer (pos. 5) and lock nut (pos. 8) with washer (pos. 7) on the lower support bracket on the chassis.
2	Mount the radiator support with the rubber buffer (pos. 6) and lock nut (pos. 8) with washer (pos. 7) on the upper radiator mount and onto the chassis.

NOTE

For an optimum of cooling efficiency, we recommend to install the radiator in an angle of 25° +/- 5° tilted backwards.

⚠ WARNING

Non-compliance can result in serious injuries or death!

For radiator installation to the chassis, please follow the instruction of the chassis manufacturer.

Step	Procedure
3	Put the four supplied hose clamps (pos. 10) on the coolant hoses.
4	Push the upper coolant water hose (pos. 2) onto the upper socket of the radiator as well onto water socket of the cylinder head cover.
5	Push the lower coolant water hose (pos. 3) onto the lower socket of the radiator as well onto the water socket of the water pump housing.

Step	Procedure
6	Secure the coolant hoses with the hose clamps (pos. 10).
7	Secure the upper coolant water hose to the driver's seat (pos. 2) using the provided cable tie.

ATTENTION

The coolant water hose between radiator and engine must not rub with the drivers seat.
Arrange the routing of the coolant water hose accordingly.

Step	Procedure
8	Secure the lower coolant water hose (pos. 3) using two of the provided cable ties to the chassis.

⚠ WARNING

Non-compliance can result in serious injuries or death!

Please follow the instruction of the chassis manufacturer for mounting the lower coolant water hose to the chassis.

Step	Procedure
9	Establish connection between overflow socket on radiator filling socket and the overflow bottle with an appropriate piece of hose.

ATTENTION

Warrant the best possible engine cooling.
Ensure that the air stream covers the complete radiator area.

BRP-Rotax
INSTALLATION MANUAL

INTAKE SILENCER

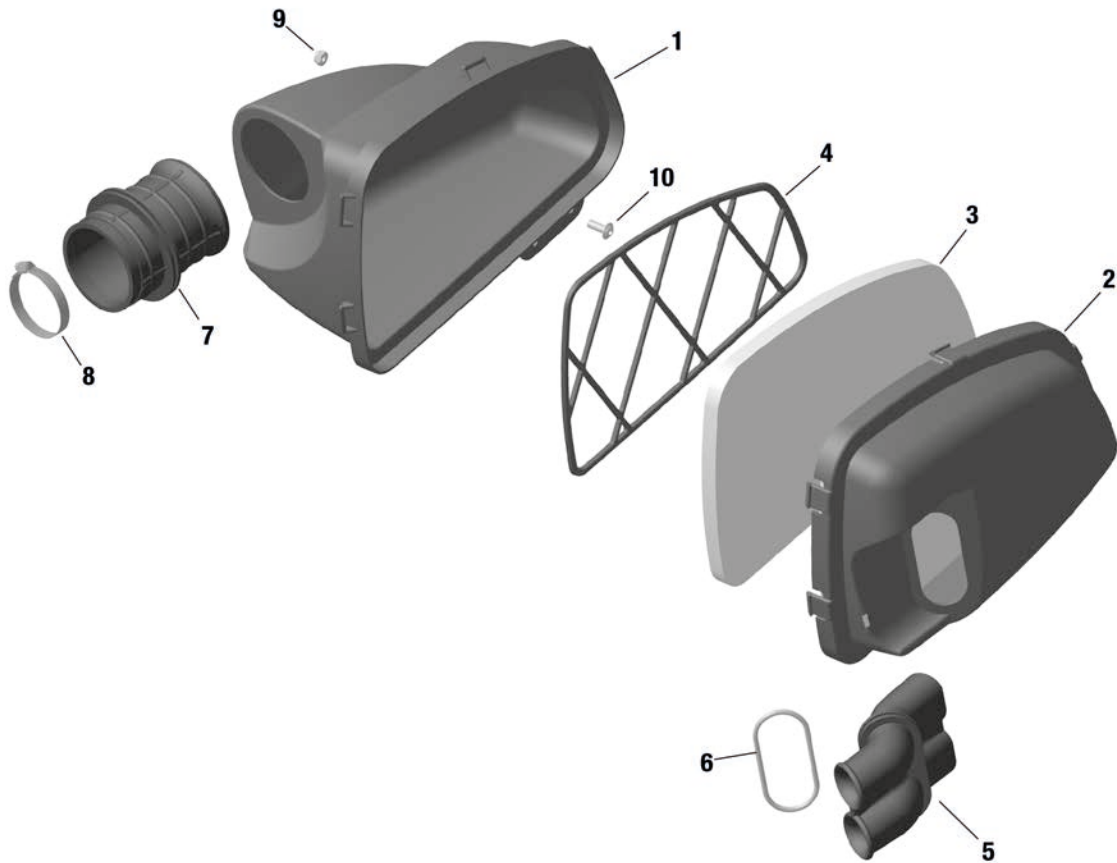

Figure 5.2: Overview

- | | | | |
|---|----------------------|----|------------------------------------|
| 1 | Intake silencer case | 2 | Intake silencer cover |
| 3 | Filter element | 4 | Holder for filter element |
| 5 | Intake silencer tube | 6 | O-ring |
| 7 | Carburetor socket | 8 | Clamp 50–70 |
| 9 | Lock nut M6 | 10 | Allen screw w. rounded flange head |

INSTALLATION OF THE INTAKE SILENCER WITH INTEGRATED AIRFILTER

Tools required:	
<ul style="list-style-type: none">• Allen key 4 mm• Ratchet wrench with socket 7 mm or Phillips screwdriver	

Step	Procedure
1	Install the rubber intake pipe (pos. 5) in a vertical position into the bottom half (pos. 2) of the intake silencer so that the rounded intake openings point outwards.
2	Fit the carburetor socket (pos. 7) into the inner side half of silencer (pos. 1) so that the arrow on the socket points towards the carburetor.
3	Install the filter element (pos. 3) with holder (pos. 4).
4	Assemble filter box and filter insert as shown in the intake silencer overview figure. Make sure that the locking is interlocked properly.
5	Attach the intake silencer with the supplied hose clamps (pos. 8) to the carburetor.

NOTE

The carburetor socket (pos. 7) is slightly tilted in one direction and can be turned so that the best possible position between carburetor and intake silencer can be achieved.

Step	Procedure
6	Attach the intake silencer on the chassis using the M6 Allen screw with rounded flange head (pos. 10).

BRP-Rotax
INSTALLATION MANUAL

NOTES

BRP-Rotax
INSTALLATION MANUAL

Chapter: 5
EXHAUST SYSTEM

TOPICS IN THIS CHAPTER

Exhaust system overview.....2
Installation of the exhaust system3

BRP-Rotax
INSTALLATION MANUAL

EXHAUST SYSTEM OVERVIEW

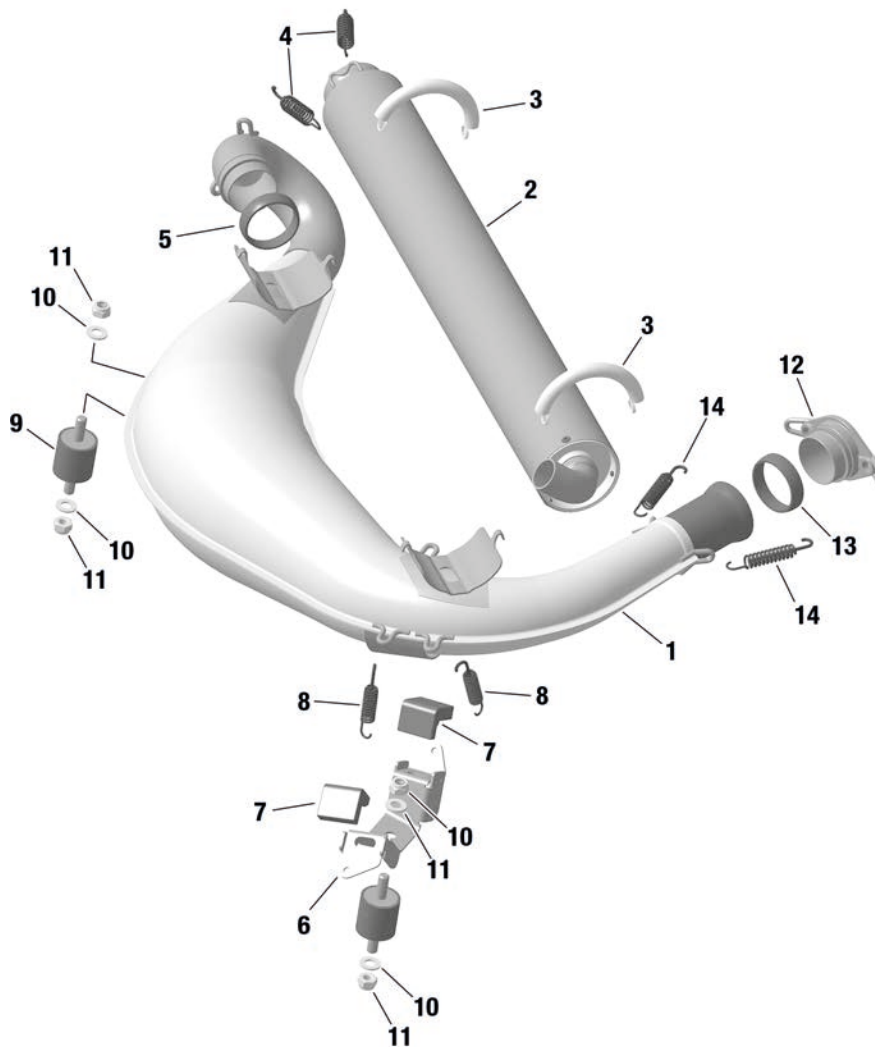

Figure 6.1

- | | |
|-------------------|-------------------------|
| 1 Exhaust system | 2 Silencer assy. |
| 3 Tension spring | 4 Spring stainless |
| 5 Exhaust gasket | 6 Retaining plate |
| 7 Rubber buffer | 8 Spring stainless |
| 9 Rubber buffer | 10 Washer 8.4 |
| 11 Lock nut M8 | 12 Exhaust socket assy. |
| 13 Exhaust gasket | 14 Spring stainless |

BRP-Rotax INSTALLATION MANUAL

INSTALLATION OF THE EXHAUST SYSTEM

Tools required:

- Open-end wrench 13 mm
- Spring hook

NOTE

On the underside of the exhaust system, two different mounting mechanisms are provided. At the front, the assembly is carried out with rubber buffers (pos. 7) between the retaining plate (pos. 6) and the exhaust system and attached by extension springs (pos. 8). At the rear, the exhaust system is mounted directly using a rubber mount M8 (pos. 9).

ATTENTION

A rigid suspension of the exhaust system could result in fractures in the exhaust system.

Step	Procedure
1	Attach the heat-resistant rubber mount (pos. 9) to the support lug on the underside of the exhaust.
2	Arrange the chassis-specific supports so that the exhaust system follows the straightest possible course from the exhaust socket on the cylinder to the muffler.
3	The gasket (pos. 13) is the only sealing between engine and the exhaust system. Additional heat-resistant LOC-TITE is not necessary anymore.

Step	Procedure
4	Secure the exhaust system on the exhaust socket using the two supplied exhaust springs (pos. 14).

NOTE

For easier installation use the special tool "Spring hook" part no. 251680.

ATTENTION

Do not over-stress the springs when fitting them.

Step	Procedure
5	Attach the exhaust system on the chassis supports such that the sealing of the ball joint between cylinder and exhaust system will not be impaired.

BRP-Rotax
INSTALLATION MANUAL

NOTES

BRP-Rotax
INSTALLATION MANUAL

Chapter: 6
INSTALLATION OF THE ACCESSORIES

TOPICS IN THIS CHAPTER

Installation of mounting plate	2
Fitting of the spark plug.....	3
Installation and connection of the RAVE control unit	4
Assembly of paddle shift system.....	7

INSTALLATION OF MOUNTING PLATE

Tools required:

- Allen key 6 mm

Step	Procedure
1	The holding bracket, the mounting plate, the solenoid valve and the ignition coil are already pre-assembled.
2	Install whole bracket kit with Allen screw M8x50 (pos. 2) and distance sleeve 8.2/12/25.5 (pos. 3) onto the engine.

ATTENTION

Slot of mounting plate has to be installed in the correct position.

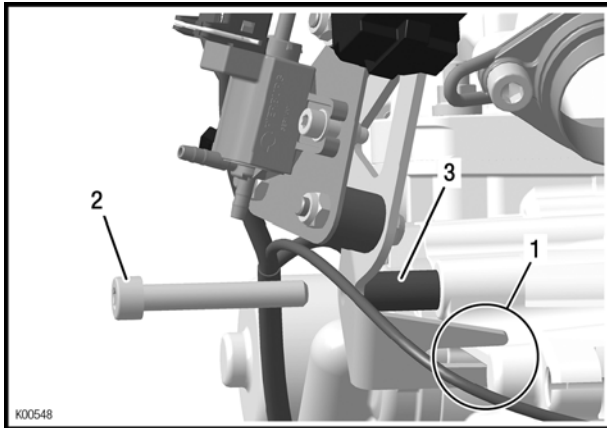

Figure 7.1

- 1 Slot 2 Allen screw M8x50
3 Distance sleeve 8.2/
12/25.5

NOTE

Distance sleeve (pos. 3) has to be install between engine housing and retaining plate. Distance sleeve can be replaced by fitting of an additional seat stay.

BRP-Rotax INSTALLATION MANUAL

FITTING OF THE SPARK PLUG

The engine will be supplied with a spark plug.

Tools required:

- Feeler gauge
- Socket 21 mm
- Torque wrench

Step	Procedure
1	Remove the transport plug from the cylinder head.
2	Check electrode gap of spark plug. Adjust as required.

NOTE

Check technical regulations to assure conformity when setting the electrode gap.

Step	Procedure
3	Fit supplied spark plug (pos. 1) and tighten 25 Nm (221 lbf in) to 27 Nm (239 lbf in).
4	Install the spark plug connector (pos. 2), ensure correct engagement.

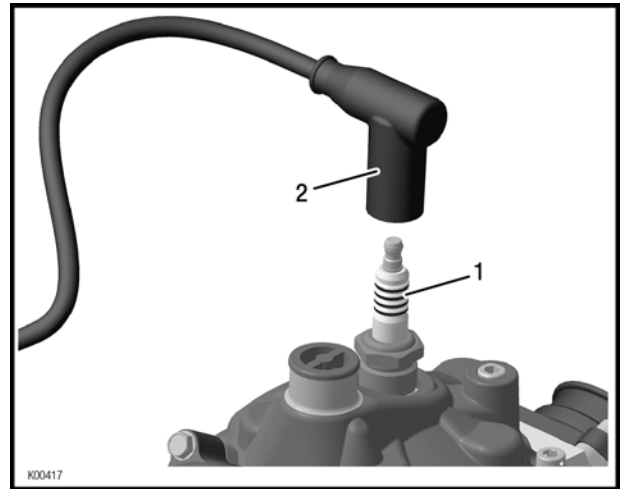

Figure 7.2

1 Spark plug

2 Spark plug connector

BRP-Rotax INSTALLATION MANUAL

INSTALLATION AND CONNECTION OF THE RAVE CONTROL UNIT

NOTE

The hose package of the RAVE control is already pre-assembled.

NOTE

The impulse restrictor is offered optionally.

Step	Procedure
1	Insert impulse nozzle (pos. 6) about 25 mm into the 420 mm pressure line (pos. 7) using an Allen key SW4. Pay attention to the mounting direction! It also works without an impulse nozzle, this only serves to choke the opening of the exhaust valve.

NOTE

In order to prevent the displacement of the impulse nozzle (pos. 6), a small cable tie (pos. 8) should be attached directly afterwards to the pressure line. Do not tie up the pressure line completely!

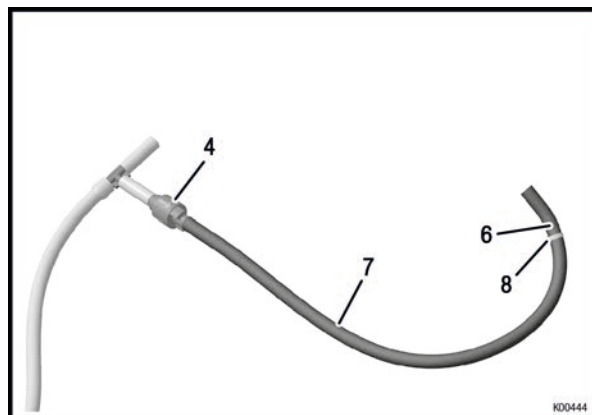
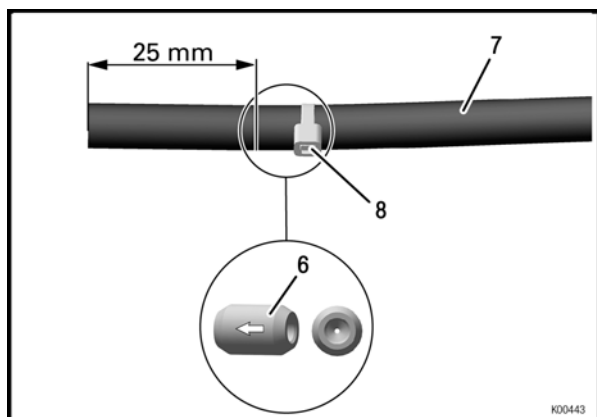

Figure 7.3

- 4 Check valve
- 6 Impulse nozzle
- 7 Pressure line
- 8 Tie wrap small

Step	Procedure
2	Attach the black hose of the hose package (pos. 1) to the metal connector (pos. 2) of the magnetic valve

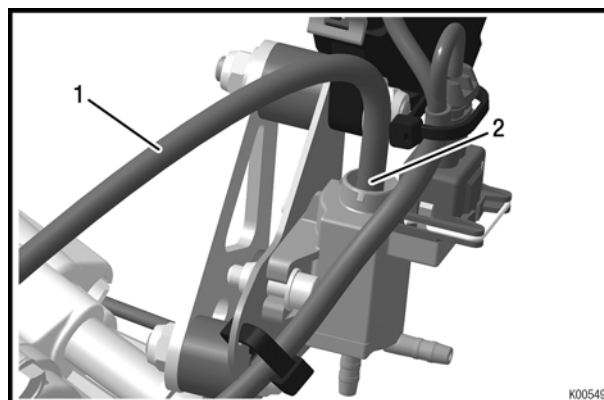

Figure 7.4

- 1 Hose package
- 2 Metal connector

Step	Procedure
3	Attach the other end of the hose package (pos. 1) (short end with T-piece) to the fuel pump.

BRP-Rotax INSTALLATION MANUAL

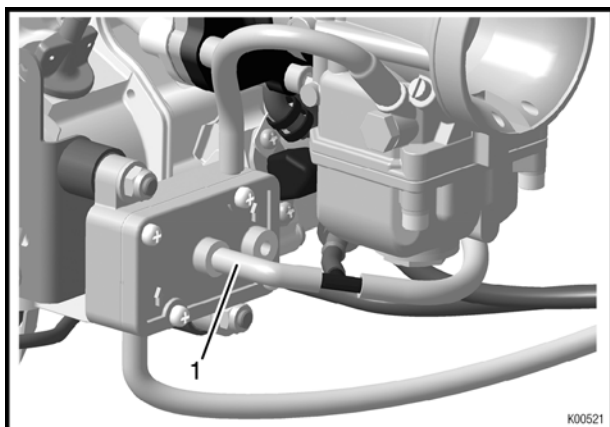

Figure 7.5

1 Hose package

Step	Procedure
4	Attach the fuel line of the hose package (pos. 1) to the impulse nipple on the engine housing..

NOTE

Check that valve is not the lowest point of the impulse circuit to prevent that condensation affects a proper operation.

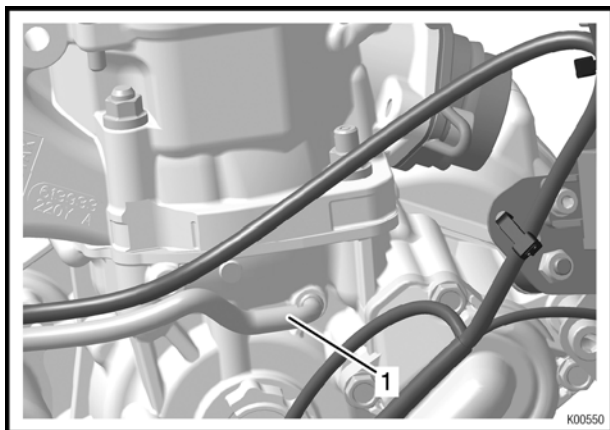

Figure 7.6

1 Hose package

Step	Procedure
5	Attach cable tie with mount (pos. 1) to the housing.

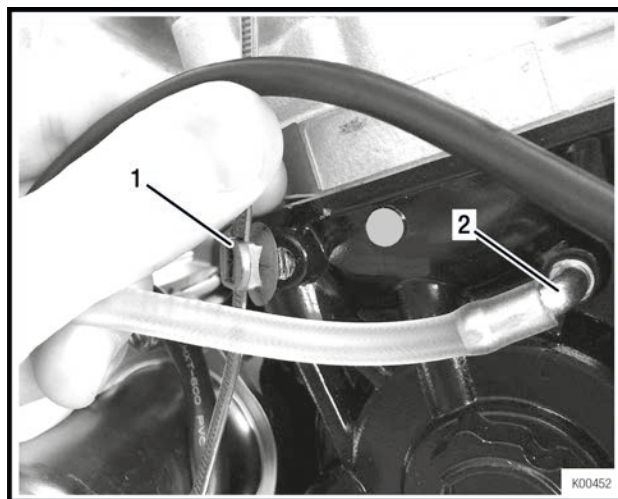

Figure 7.7

1 Cable tie

2 Impulse nipple

Step	Procedure
6	Secure both lines with cable tie, ensuring that the black hose is on top.

ATTENTION

Do not tighten cable ties too tight, because constricted lines can lead to loss of function.

Step	Procedure
7	Attach an additional cable tie (pos. 3) as shown in figure.

BRP-Rotax INSTALLATION MANUAL

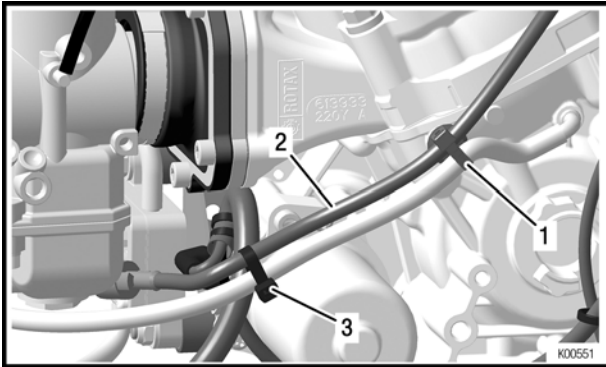

Figure 7.8: Cable tie

- 1 Cable tie
- 2 Black hose
- 3 Cable tie

Step	Procedure
8	Attach the 220 mm pressure line (pos. 1) to the magnetic valve (pos. 3). Secure the pressure line on the magnetic valve with a tie wrap (pos. 4). Attach the other end of the pressure line to the exhaust valve (pos. 2).

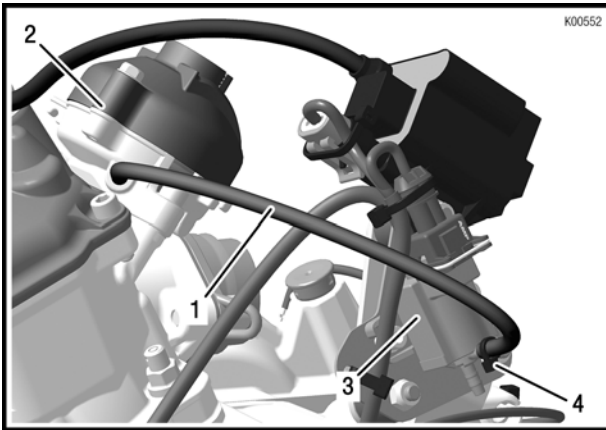

Figure 7.9

- 1 Pressure line
- 2 Exhaust valve
- 3 Magnetic valve
- 4 Cable tie

BRP-Rotax INSTALLATION MANUAL

ASSEMBLY OF PADDLE SHIFT SYSTEM

Tools required:	
<ul style="list-style-type: none"> • Allen key 6 mm • Allen key 5 mm 	

Step	Procedure
1	Install spacer (pos. 1) into the appropriate bore (pos. 2) of the engine housing.

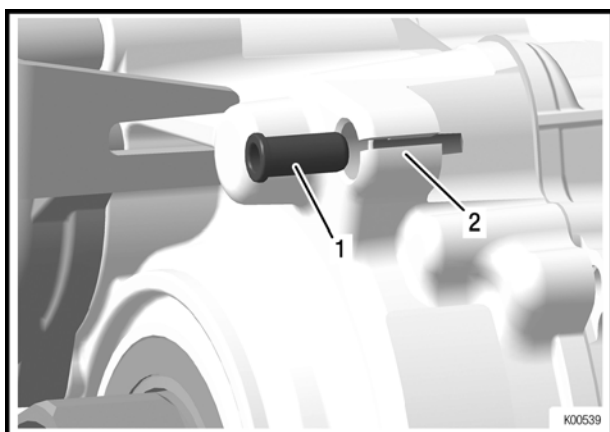

Figure 7.10

1 *Spacer* 2 *Appropriate bore*

Step	Procedure
2	Install washer (pos. 1) on one of the two Bowden cables (pos. 2).

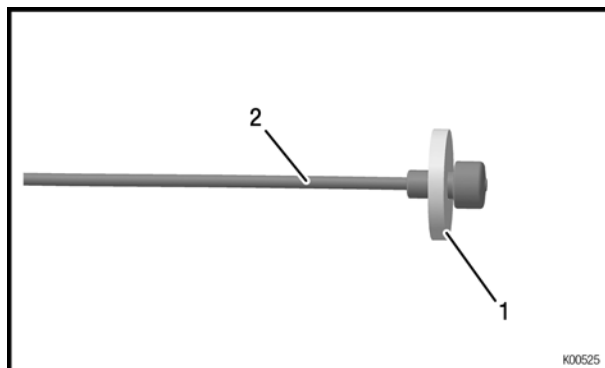

Figure 7.11

1 *Washer* 2 *Bowden cable*

Step	Procedure
3	Mount Bowden cable (pos. 2) with washer (pos. 1) onto the shift contact guidance (pos. 3).

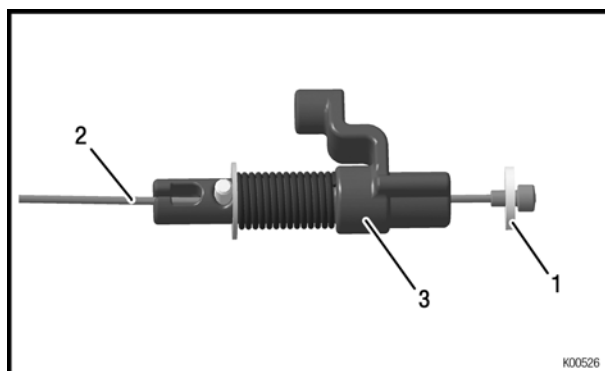

Figure 7.12

1 *Washer* 2 *Bowden cable*
3 *Shift contact guidance*

Step	Procedure
4	Mount Bowden cable with shift contact guidance (pos. 1) to the retaining plate (pos. 2).

BRP-Rotax INSTALLATION MANUAL

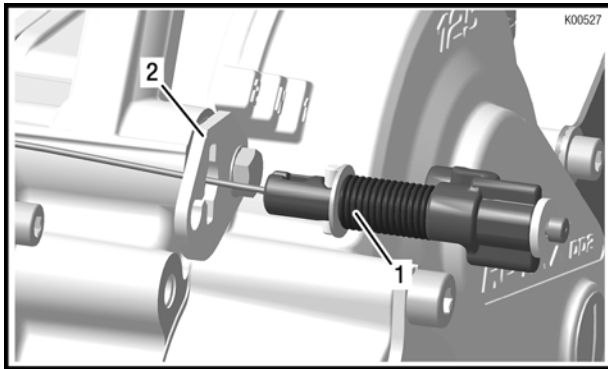

Figure 7.13

- 1 Shift contact guidance 2 Retaining plate

Step	Procedure
5	Mount Allen screw (pos. 1), lock washer (pos. 2) and spacer (pos. 3) together with the shift contact guidance (pos. 4) to the engine housing. Tightening torque 22 Nm.

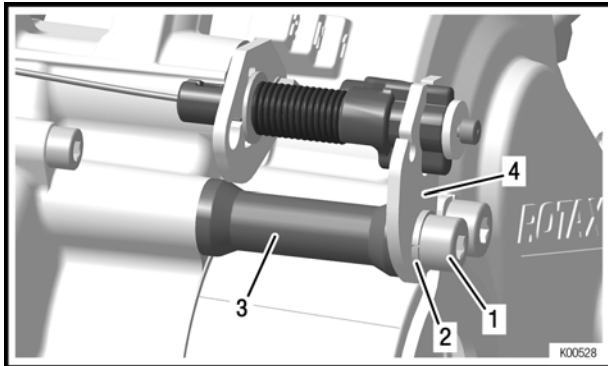

Figure 7.14

- 1 Allen screw 2 Lock washer
3 Spacer 4 Shift contact guidance

Step	Procedure
6	The alignment between point -1- and point -2- must be given. Otherwise it can cause increased friction, which has a negative impact on shifting behavior.

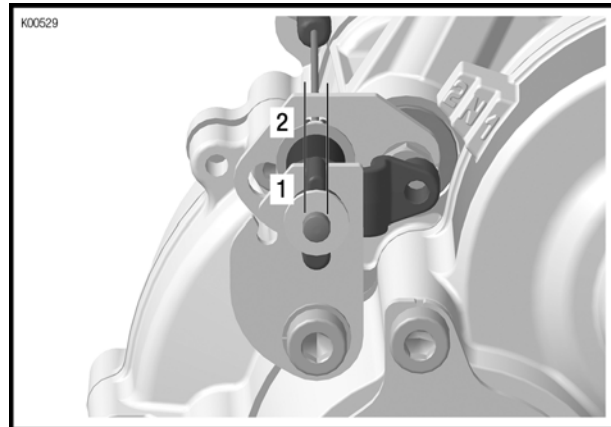

Figure 7.15

- 1 Point 1 2 Point 2

Step	Procedure
7	Mount sleeve (pos. 1) onto the retaining plate (pos. 2).

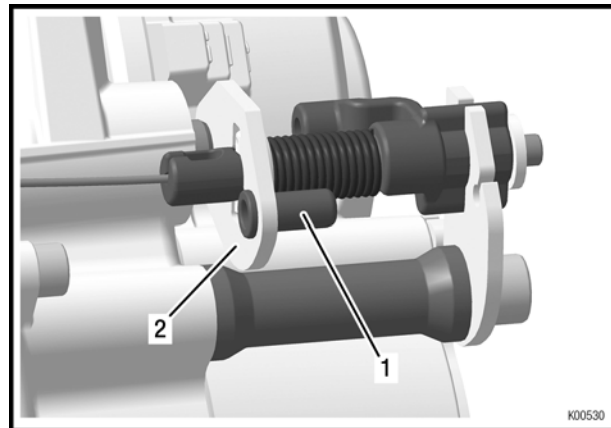

Figure 7.16

- 1 Mount sleeve 2 Retaining plate

Step	Procedure
8	Mount second Bowden cable (pos. 1) through shift contact guidance and sleeve onto the retaining plate (pos. 2). No washer is necessary on this Bowden cable.

BRP-Rotax INSTALLATION MANUAL

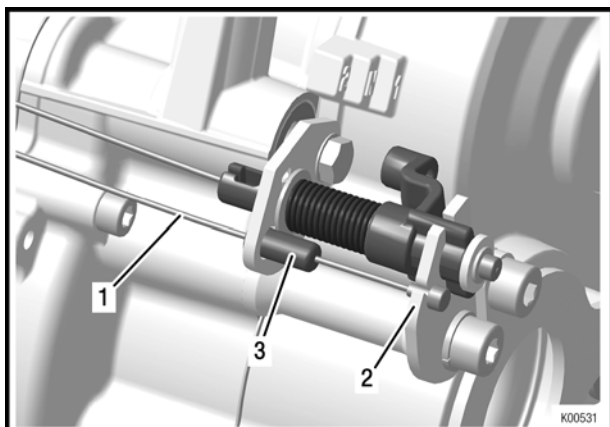

Figure 7.17

- 1 Bowden cable
- 2 Retaining plate
- 3 Guidance

Step	Procedure
9	Install Bowden cables (pos. 1) into the support on the back of the engine.

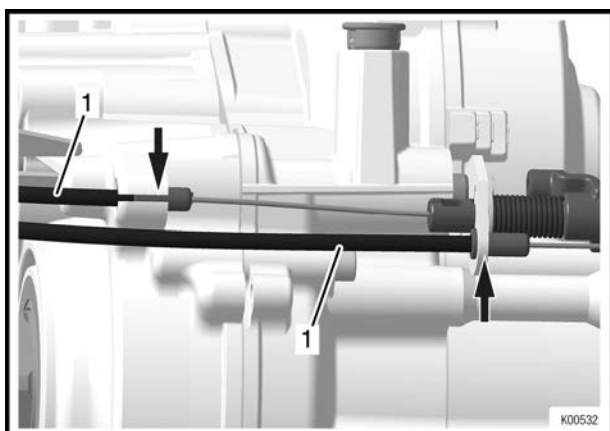

Figure 7.18

- 1 Bowden cable

Step	Procedure
10	Thread both ends of the Bowden cables (pos. 1) through the cable support (pos. 2). Install the set screw (pos. 3) onto the cable support – just pre-assemble it, do not tighten yet.

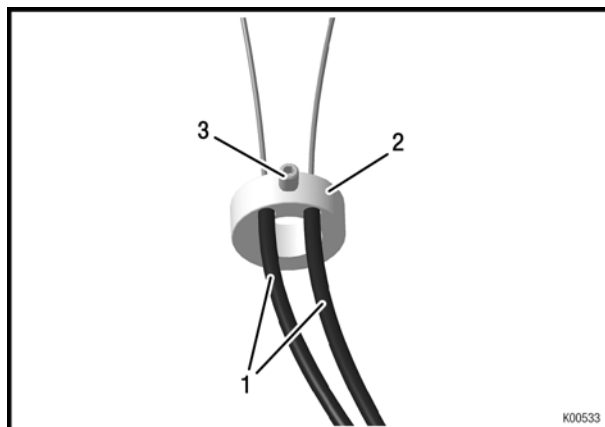

Figure 7.19

- 1 Bowden cables
- 2 Cable support
- 3 Set screw

Step	Procedure
11	Hand-tighten both Bowden cables (pos. 1) onto the control whip (pos. 2), using M6. Allen screws (pos. 3) and washers (pos. 4). Pay attention to the correct installation of the control whip!

NOTE

The oblique millings (pos. 5) of the control whip serve to guide the cables. The cable ends must look away from the center of the control whip.

The Bowden cables can be attached to the control whip in two different ways:

- Version 1:

Fasten Bowden cable to position 5 inside.
Feature: Shift travel longer, but less effort.

- Version 2

Fasten Bowden cable to position 5 outside.
Feature: Short shift, but higher effort.

BRP-Rotax INSTALLATION MANUAL

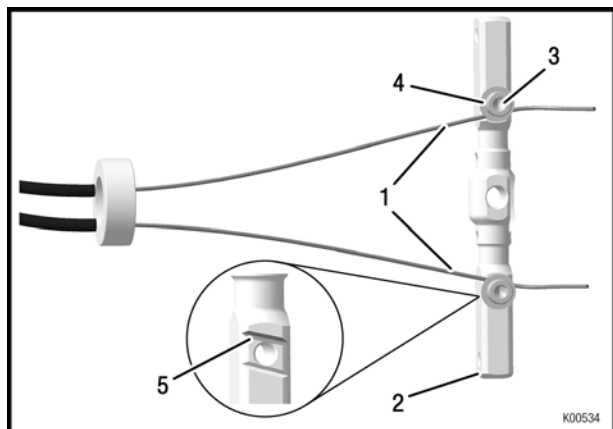

Figure 7.20

- 1 Bowden cable
- 2 Control whip
- 3 Allen screw
- 4 Washer
- 5 Oblique millings

Step	Procedure
12	Hand-tighten control lever left and right (pos. 1) onto the control whip (pos. 4), using M6 Allen screws (pos. 2) and washers (pos. 3).

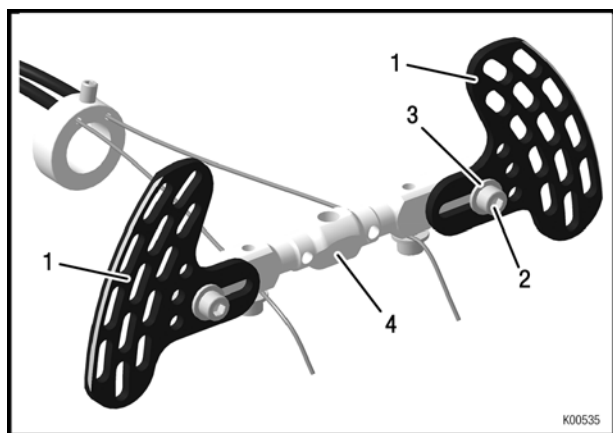

Figure 7.21

- 1 Control lever
- 2 Allen screw
- 3 Washer
- 4 Control whip

NOTE

The control lever can also be attached on the back, depending on how it is more ergonomic for the driver.

Step	Procedure
13	Install spacer (pos. 1) with washer (pos. 2) onto the bottom side of the control whip (3).

NOTE

The bottom side is, where the screws of the Bowden cables are fixed.

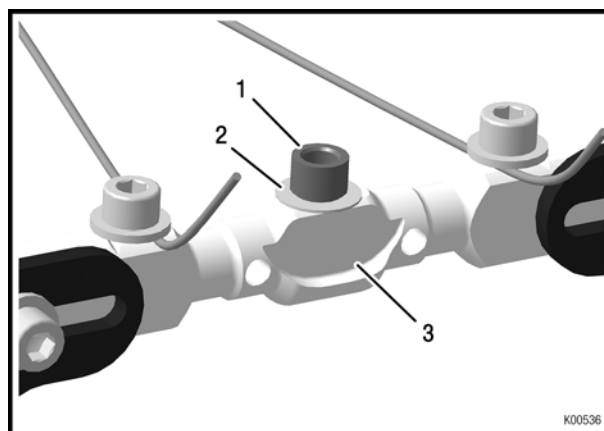

Figure 7.22

- 1 Spacer
- 2 Thrust washer
- 3 Control whip

Step	Procedure
14	Tighten Allen screw M6x60 (pos. 1) and washer (pos. 2) onto the top of the control whip (pos. 3).

NOTE

Top is the opposite side, where the screws of the Bowden cables are attached.

BRP-Rotax INSTALLATION MANUAL

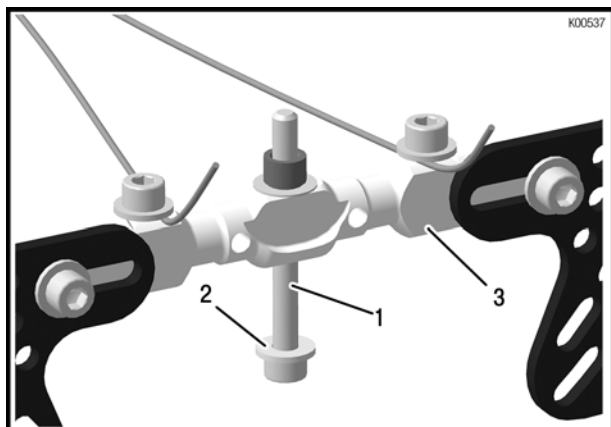

Figure 7.23

- 1 Allen screw M6x60 2 Washer
- 3 Control whip

Step	Procedure
15	Place the entire shifting unit onto the steering wheel and tighten it using Allen screw M6x 60 (pos. 3), M6 lock nut (pos. 1) with washer (pos. 2).

NOTE

Control whip must run smoothly.

NOTE

Spacer must fit into the bore provided on the steering wheel.

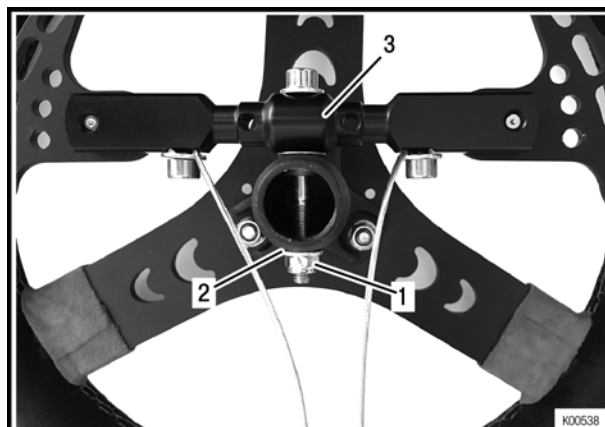

Figure 7.24

- 1 Lock nut M6 2 Washer
- 3 Allen screw M6x60

Step	Procedure
16	The setting of the shifting is carried out in neutral gear, which means that the control whip must be in horizontal position.
17	Tighten screw (pos. 2) of the cable abutment (pos. 1) and the screws of the Bowden cables on the control whip (pos. 3).

NOTE

At full steering angle, no gear must engage. If a gear engages by itself, the distance between control whip and cable abutment must be adjusted.

Step	Procedure
18	Finally, the length of the Bowden cables can be adjusted so that they do not disturb the driver when shifting.

BRP-Rotax
INSTALLATION MANUAL



Figure 7.25

- 1 Cable abutment
- 2 Screw
- 3 Control whip

BRP-Rotax
INSTALLATION MANUAL

Chapter: 7
FINISHING WORK

TOPICS IN THIS CHAPTER

Check oil level in gearbox.....	2
Venting of the gear compartment	4
Run-in procedure	4

NOTE

To determine the best possible transmission ratio, the use of a rev-counter is required for observation of the speed limits.

NOTE

To warrant engine operation within temperature limits of the coolant, a temperature sensor for observation of the coolant temperature is required.

NOTE

Refer to Operators Manual for operating limits.

BRP-Rotax INSTALLATION MANUAL

CHECK OIL LEVEL IN GEARBOX

The gearbox is already filled with the appropriate amount of oil by the engine manufacturer. However, before the engine is installed in the frame, the oil level must be verified or replenished.

Step	Procedure
1	Place engine on a horizontal surface and/or assembling trestle.

ATTENTION

When placing the engine on a horizontal surface, take care not to damage the crankcase sensor, which is mounted on the bottom of the crankcase.

Step	Procedure
2	The oil level can be checked on inspection glass (pos. 1). It should reach approximately to one-third of the inspection glass, see following figure. If the oil level is not sufficient, replenish oil as described in the following steps.

NOTE

For gearbox oil specifications and oil capacity (total) see the latest Operators Manual.

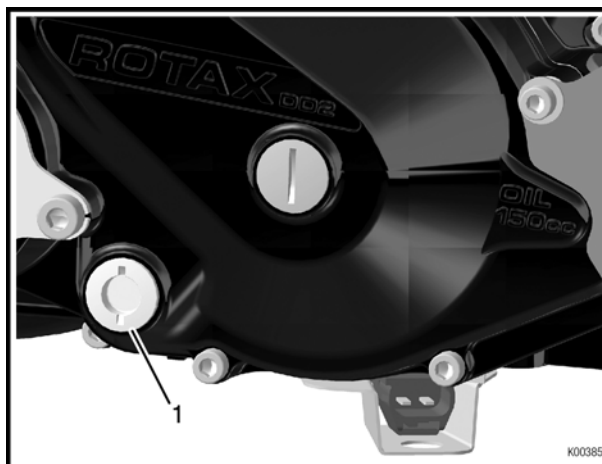

Figure 8.1

1 Inspection glass

Step	Procedure
3	Remove the air vent screw (pos. 1) and slowly fill in oil until oil level is in the middle of the inspection glass.
4	Hand-tighten air vent screw (pos. 1).

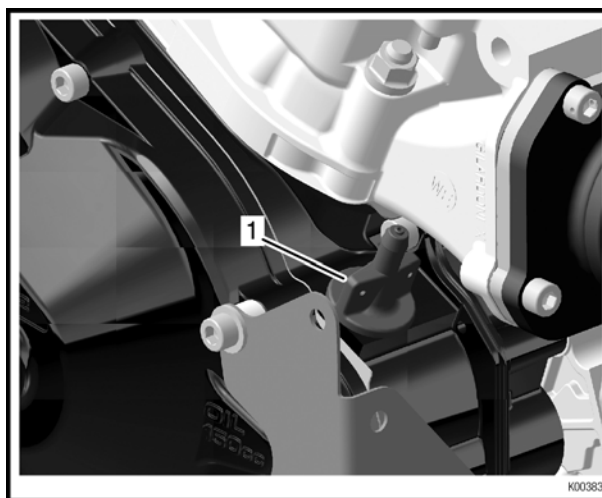

Figure 8.2

1 Air vent screw

BRP-Rotax INSTALLATION MANUAL

NOTE

For draining the oil from the gear case, remove the magnetic oil drain plug (pos. 1) and sealing ring (pos. 2). Clean the oil drain plug before installation. Always use a new sealing ring.

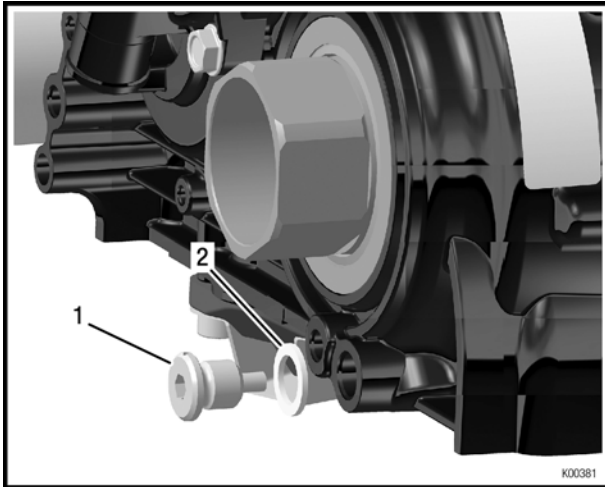

Figure 8.3

- 1 Magnetic oil drain plug 2 Sealing ring

NOTE

Tighten magnetic oil drain plug (pos. 1) to 20 Nm (177 lbf.in.).

⚠ WARNING

Non-compliance can result in serious injuries or death!

Do not run the engine without gear oil. This will lead to engine failure.

BRP-Rotax
INSTALLATION MANUAL

VENTING OF THE GEAR COMPARTMENT

Step	Procedure
1	Remove cap from the venting screw.
2	Establish a connection between the venting screw and a collecting reservoir using a piece of the supplied fuel hose of an appropriate length.

NOTE

The venting hose must not reach all the way to the bottom of the collecting reservoir.

ATTENTION

Do not attach the venting hose on the bottom of the collecting reservoir, if only one reservoir is in use.

Run-in Procedure

⚠ WARNING

Non-compliance can result in serious injuries or death!

Running in has to be done with a "long" gear ratio and a rich main jet (2 sizes bigger than the recommended main jet size based on altitude and temperature - see operators manual) as follows:

ATTENTION

For the first 10 liters of fuel use a mixing ratio of 1:33 (=3% or 0,3 liter oil per 10 liters fuel).

NOTE

BRP - Powertrain recommends to use XPS Kart -Tec oil.

Step	Procedure
1	15 min. up to 10.000 rpm 15 min. up to 12.000 rpm 15 min. full load
2	Reduce the main jet size step by step (e.g. 172 - 170 - 168 ...)

NOTE

Make sure that the coolant temperature reaches a minimum of 55°C (130 °F).

At cold ambient temperature radiator needs to get partly covered by tape.

BRP-Rotax
INSTALLATION MANUAL

Index

B

Battery, installation5
Bowden cable, installation.....4

C

Carburetor, connection6
Carburetor, installation.....6
Cooling system1
Cooling system overview2

D

Direct attachment of the engine to chassis5

E

ECU, Installation3
Electric system.....1
Electric system overview.....2
Engine information3
Engine, installation3
Exhaust system1
Exhaust system overview2
Exhaust system, installation3

F

Finishing work.....1
Fuel pump, connection2
Fuel pump, installation.....2
Fuel system, installation1

I

Intake silencer4
Intake silencer, installation5
INTRO1

M

Mounting plate, installation.....2

O

Oil level, check in gearbox2
Overload clutch, installation2

P

Paddle shift system, assembly7

R

Radiator, installation3
RAVE control unit, installation4
Run-in Procedure4

S

Spark plug, fitting3

U

Unboxing.....1

V

Venting of the gear compartment.....4

W

Wiring harness, installation7

Operator's Manual

Table of Content

Chapter	INTRO – GENERAL INFORMATION
Chapter	1 – Technical Description
Chapter	2 – Operating fluids and battery
Chapter	3 – Engine calibration
Chapter	4 – Engine operation
Chapter	5 – Preservation and transport

BRP-Rotax
Operators Manual

NOTES

BRP-Rotax
Operators Manual

Chapter: INTRO
GENERAL INFORMATION

Preface

Before operating the engine, read the Operators Manual carefully.
If any passages of the Manual are not clearly understood or if you have questions, please contact an authorized Distribution or Service Center for ROTAX®-kart engines.
This document and all technical data and procedures therein are property of BRP-Rotax GmbH & Co KG and based on the state of knowledge at the time of publication The Manual has been drawn up to the best of our knowledge. However, excluding any liability. We reserve all rights including technical modification and possibility of errors. Reprinting, translation or copies in whole or in part, are authorized only after written permission by BRP-Rotax GmbH & Co KG.
BRP-Rotax GmbH & Co KG reserves the right at any time to discontinue or change specifications, prices, designs, features, models or equipment without incurring obligation. Engine performance may vary depending on, among other things, general conditions, ambient temperature and altitude.

Contents

This Operators Manual contains instructions about how to operate the ROTAX®-Engine Type 125 MAX DD2 evo.

Symbols used

This Manual uses the following symbols to emphasize particular information. This information is important and must be observed.

⚠ WARNING
Identifies an instruction, which if not followed may cause injury or endanger the life of the driver, mechanic or third party.

ATTENTION
Denotes an instruction which if not followed may severely damage the engine. Noncompliance might lead to health hazards under certain conditions.

<u>ENVIRONMENTAL NOTE</u>
Environmental notes give you tips on environmental protection.

NOTE

Indicates supplementary information which may be needed to fully complete or understand an instruction.

✓ Denotes a checking operation

TIP This information gives you additional advice and tips

BRP-Rotax
Operators Manual

NOTES

BRP-Rotax
Operators Manual

Chapter: 1
TECHNICAL DESCRIPTION

TOPICS IN THIS CHAPTER

Design of the ROTAX engine 125 MAX DD2 evo.....	2
General	2
Cooling circuit	2
Balance gear.....	3
Ignition unit	3
Electric starter	3
Electro pneumatically exhaust timing control	3
Intake silencer.....	3
Exhaust system.....	4
Gearbox	4
Electronic Shifting Assistant (ESA)	4
Fuel pump	4
Carburetor	4
Centrifugal clutch	5
Overload clutch	5

DESIGN OF THE ROTAX ENGINE 125 MAX DD2 EVO

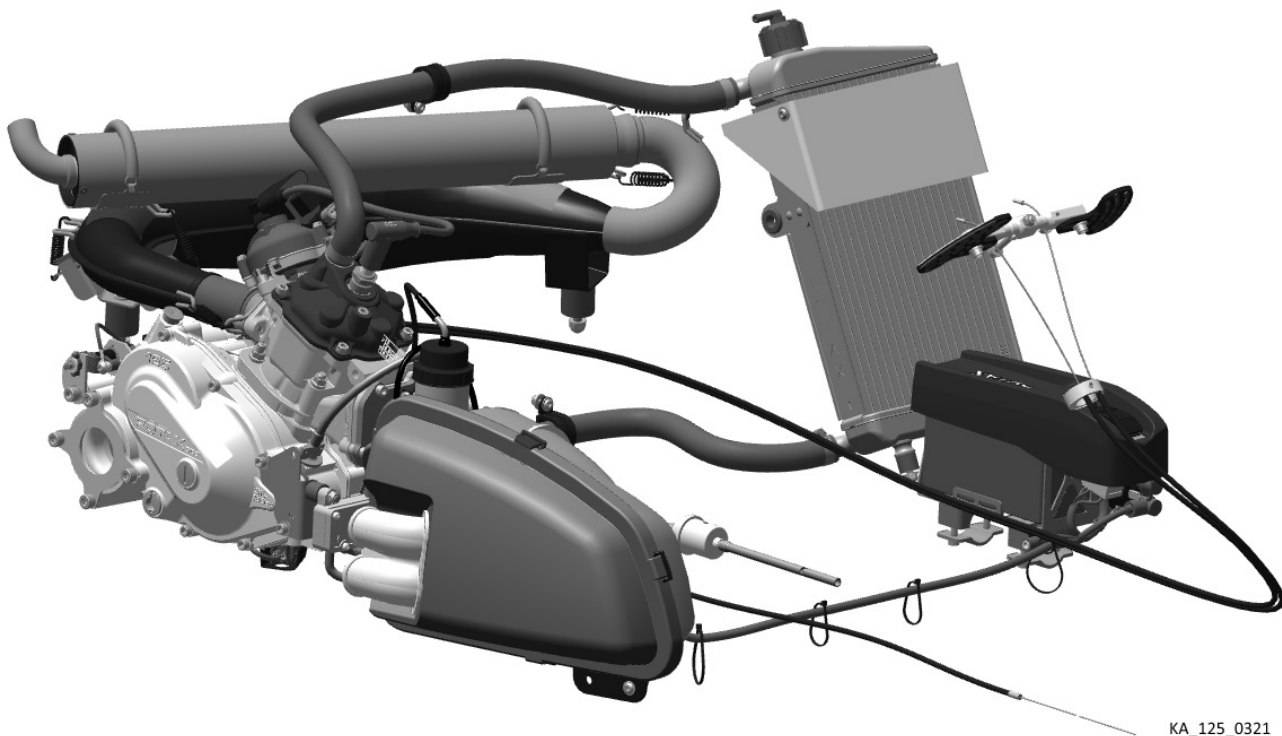

Figure 1.1

GENERAL

The Rotax 125 MAX DD2 evo engine is a single cylinder two stroke engine with reed valve controlled inlet and 125 cm³ displacement. Mixture lubrication is achieved by adding oil to the gasoline in a specified mixing ratio.

The power transmission to the rear axle takes place via a manually shift able integrated 2-speed gearbox.

COOLING CIRCUIT

The coolant is pumped from the radiator to the water pump which is driven by the clutch shaft. The water pump conveys the coolant through cylinder and the cylinder head back to the radiator.

The cooling circuit is equipped with a thermostat (opening point 45 °C / 113 °F). It assures that the engine reaches its operating temperature quickly and keeps it at a relatively constant level.

The thermostat is integrated in the cylinder head cover.

BRP-Rotax

Operators Manual

BALANCE GEAR

The balance gear is mounted on the primary shaft and rotates counter-wise to the crankshaft to reduce engine vibration.

IGNITION UNIT

The control of the ignition system is exercised by the ECU (Engine Control Unit). To calculate the ignition timing, an engine speed sensor is needed, which is installed on the bottom of the engine housing. There is no manual adjustment of the ignition system necessary and/or possible.

If the power button is pressed once, the ignition is activated and the button lights up. To start the engine, it only needs to be pressed once again. To turn off the engine as well as the ignition, proceed in reverse order.

ELECTRIC STARTER

By pressing the "START" button, the circuit between the battery and the electric starter will be closed by a relay. The electric starter drives the starter gear on the crankshaft via an intermediate gear with free wheeling, until the engine starts to run. An automatic switch reset from "START" to "ON" is integrated.

ELECTRO PNEUMATICALLY EXHAUST TIMING CONTROL

The engine type 125 MAX DD2 evo is equipped with an electro-pneumatic exhaust control. The E-RAVE (Electronic ROTAX Adjustable Variable Exhaust) system is controlled by an electro-pneumatic valve via the ECU. The vacuum required is provided by the engine crankcase.

If the engine is running at idle speed or below the opening point of the E-RAVE system (between approximately 8000-9000 rpm) the exhaust valve is closed. With the engine running, it closes or opens the electro-pneumatic valve of the exhaust depending on the speed and, therefore it provides optimum performance characteristics.

INTAKE SILENCER

The intake silencer incorporates an air filter to clean the intake air. The intake silencer has been designed for optimum reduction of air intake noise level and represents a tuned system with the engine.

The air filter consists of several layers and has been optimized in the area of air passage and filter efficiency. If soiled or during engine maintenance work, clean the filter with biodegradable products.

EXHAUST SYSTEM

The exhaust system is designed as resonance system with an after-muffler and represents a tuned system with engine.

GEARBOX

The power transmission to the rear axle takes place via manually shiftable integrated 2-speed gearbox and not as usual, via a maintenance intensive chain drive. Changing the gear activates the gear shift fork as well as a shifting sleeve, which slides on the hollow shaft between the 1st and 2nd gear and then engages in the respective idle gear.

The gear is kept in position by an index pin, which keeps the gearshift fork in the selected position, 1st gear, neutral or 2nd gear.

To allow shifting into 2nd gear without lifting the foot from the gas pedal, the ignition is cut off for a moment when actuating the shifting paddle.

ELECTRONIC SHIFTING ASSISTANT (ESA)

To optimize the shifting from 1st to 2nd gear, the ignition is interrupted for a short time. This releases load from the gearset and, gear shifting is faster and less stressful for the gearset.

FUEL PUMP

The fuel pump functions due to the alternating negative pressure and overpressure in the crankcase and sucks fuel from the fuel tank into the carburetor via the fuel pump. In the suction side of the fuel pump (between fuel tank and fuel pump) a fuel filter is installed to prevent contamination of the fuel pump and carburetor.

CARBURETOR

The carburetor (DELL'ORTO VHSB 34) is a slide type carburetor with float system. The standard main jet is suitable for almost all operating conditions. For extreme operating conditions, the main jet size must be adjusted to the actual conditions according to this manual.

BRP-Rotax

Operators Manual

CENTRIFUGAL CLUTCH

The engine is equipped with a centrifugal clutch operating in an oil bath. This clutch separates the engine from the gearbox at less than 2.500 rpm. Only at an engine speed of approx. 4.000 rpm. the centrifugal clutch is completely engaged.

OVERLOAD CLUTCH

The engine has a mechanical overload clutch, which is installed on the rear axle. It is to protect the crankshaft from hard shocks from the drive components which are not usual during normal operation (e.g. the blocking of the rear axle).

BRP-Rotax
Operators Manual

NOTES

Chapter: 2
OPERATING FLUIDS AND BATTERY

TOPICS IN THIS CHAPTER

Coolant	2
Battery	3
Battery charging unit	4
Fuel	6

See also table “important information (summary)” in Chapter 5.

BRP-Rotax

Operators Manual

COOLANT

Use only distilled water as engine coolant. If the kart is stored below the freezing temperature of water, make sure to drain the water from the cooling radiator and engine completely.

Step	Procedure
1	Open radiator cap and fill the system with coolant. Small radiator: approx. 0.52 liter / 0.137 gal for the complete cooling system Big radiator: approx. 0.7 liter / 0.185 gal for the complete cooling system
2	Close radiator cap.

ATTENTION

Observe the storage conditions.

Storage below the freezing temperature of water could lead to a damage of the cooling system and the engine.

ATTENTION

Exceeding the engine temperature could lead to serious engine failure.

The engine temperature should not exceed 85 °C / 185 °F.

BRP-Rotax

Operators Manual

BATTERY

See Fig. [Pos. 1: Charging connector](#).

The power for the ignition unit and electric starter is only supplied from the battery. With a fully charged battery of 12 V and 6.5 Ah, the engine can be started approximately one hundred times and operated over a period of approximately five hours. With the battery voltage decreasing to approximately 11 V the point will be reached when the battery voltage is too low to generate a spark for ignition.

ATTENTION

The lifespan of the battery will be drastically reduced by exhausting the battery completely.

Fully re-charge the battery before and after any operation of the kart.

NOTE

It is recommended to always carry a charged spare battery. The installed battery should be replaced with a fully charged battery before it is completely exhausted.

NOTE

If the spark plug is removed, to check if the battery still generates a spark, consider the following: with the spark plug removed it is easier for the electric starter to crank the engine, which reduces current absorption of the electric starter, resulting in battery voltage adequate to generate a spark. If the spark plug is fitted again, it may happen that the engine does not start.

NOTE

To charge a battery, the delivered battery charging unit specified by ROTAX® should be utilized (battery charger part no. 265148). When using the lithium battery available as spare part, the battery charger Optimate Lithium (part no. 581325) is mandatory.

NOTE

To be able to use the battery charger in your home country, please contact your nearest authorized ROTAX® distributor or one of their ROTAX® Service Centers to receive an adapter plug or adapter cable, respectively.

NOTE

This battery charger will switch over automatically to maintenance charge as soon as the target voltage is reached. Therefore overcharging with the result of ruining the battery will be impossible.

ATTENTION

Use of any other battery charger can impair the battery life or may ruin the battery.

BATTERY CHARGING UNIT

When charging the battery take note of the following:

Step	Procedure
1	Connect battery charger to the charging connector (pos. 1).

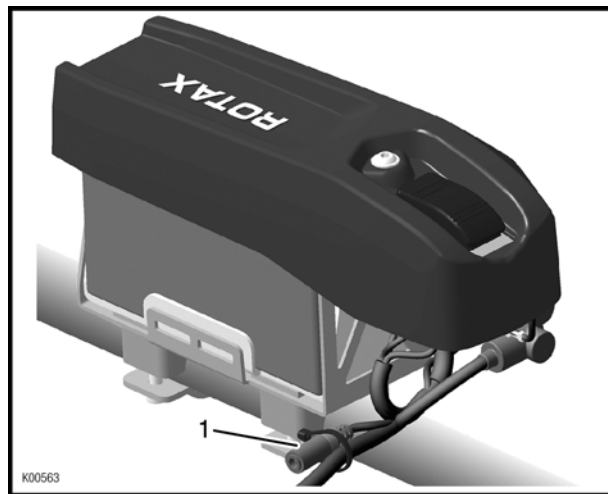

Figure 2.1: Pos. 1: Charging connector

Step	Procedure
2	Connect the battery charging unit on 110-230V, 50 - 60Hz power supply. During the charging procedure, the charge indicating lamp will light up red.
3	At completion of the charging process, the control lamp will change to green, but the charging current will remain, thus warranting a fully charged battery.
4	The charging time amounts to approx. 12 hours.

NOTE

The battery charger may be connected to the battery for a longer period, as the battery takes just the current required to be fully charged.

NOTE

A non-extinguishing red control lamp, even after 24 hours of charging, indicates that the charging capacity of the battery is diminishing.

NOTE

A red/green blinking of the charging control lamp indicates transition from main charging to additional charging and does not signal a faulty battery charger.

BRP-Rotax Operators Manual

Step	Procedure
5	Unplug power supply to battery charging unit.
6	Remove output wires of the battery charger from the battery.
7	The battery is ready again for use.

ATTENTION

In addition to these directives, follow the advice of the battery charging unit manufacturer.

NOTE

When the battery is charged while not mounted on the kart, use the connector cable (part no. 266022). If needed, contact your authorized distributor or one of their ROTAX® Service Centers.

The charging condition of the battery can be estimated by using a commercially available measuring instrument.

BRP-Rotax

Operators Manual

FUEL

For engine operation, a mixture of unleaded gasoline of at least ROZ_{min.} 95 / 91 (RON +MON) / 2 and **fully synthetic** two-stroke oil, mixed at ratio 1: 50 (2% oil) has to be used.

ATTENTION

Carry out a correct running-in procedure.

See Chapter 4 section: Running-in procedure for the engine.

⚠ WARNING

Non-compliance can result in serious injuries or death!

When mixing fuel and fuelling do not smoke or allow open fire. Gasoline is highly flammable and explosive under certain conditions.

⚠ WARNING

Non-compliance can result in serious injuries or death!

Never perform mixing and fuelling in closed rooms, handle fuel in well ventilated areas only.

⚠ WARNING

Non-compliance can result in serious injuries or death!

Fuel the kart only when engine is not running and the combination switch is at OFF position.

⚠ WARNING

Risk of fire and explosion!

Make sure that fuel will not splash onto hot engine components or equipment.

⚠ WARNING

Non-compliance can result in serious injuries or death!

Pay attention to the safety advice of the kart manufacturer.

ATTENTION

Possible engine trouble!

Too much oil in the fuel mixture (more than 2%) could lead to engine trouble (e.g. coking of the exhaust valve, piston ring sticking).

BRP-Rotax
Operators Manual

ATTENTION

Possible engine blow-up!

Insufficient amount of oil in the fuel mixture (less than 2%) could result in e.g. piston seizure.

ATTENTION

Engine damage and damage to the intake system may occur.

Do not try any different sorts of fuel.

ATTENTION

Before each fuelling, shake fuel container well to ensure adequate mixing of the gasoline with the oil.

ATTENTION

Ensure that no contamination enters the fuel tank and the carburetor.

ATTENTION

Unleaded fuel has a limited storage life.

Store only the quantity of fuel in a container which will be needed in the near future.

ENVIRONMENTAL NOTE

Don't spill fuel. Absorb spilled fuel with appropriate drying agent and ensure ecological disposal.

BRP-Rotax
Operators Manual

NOTES

Chapter: 3
ENGINE CALIBRATION

TOPICS IN THIS CHAPTER

ENGINE CALIBRATION	2
Performance graphs	2
Carburetor calibration	3
Automatic-set-up	4
Manual set-up	7
Change of the carburetor main jet	11
Choose of gear ratio	14
Exchange of gear reduction ratio	16
Operation of the gear box	18
Adjustment of gear shifting	19

ENGINE CALIBRATION

PERFORMANCE GRAPHS

In this diagram, the different performance characteristics of the MAX engines are shown. The vertical Y-axis shows the power in kilowatts (kW). The horizontal X-axis shows the rotational speed in revolutions per minute (rpm).

For more information, please check the performance data sheets on www.rotax-kart.com.

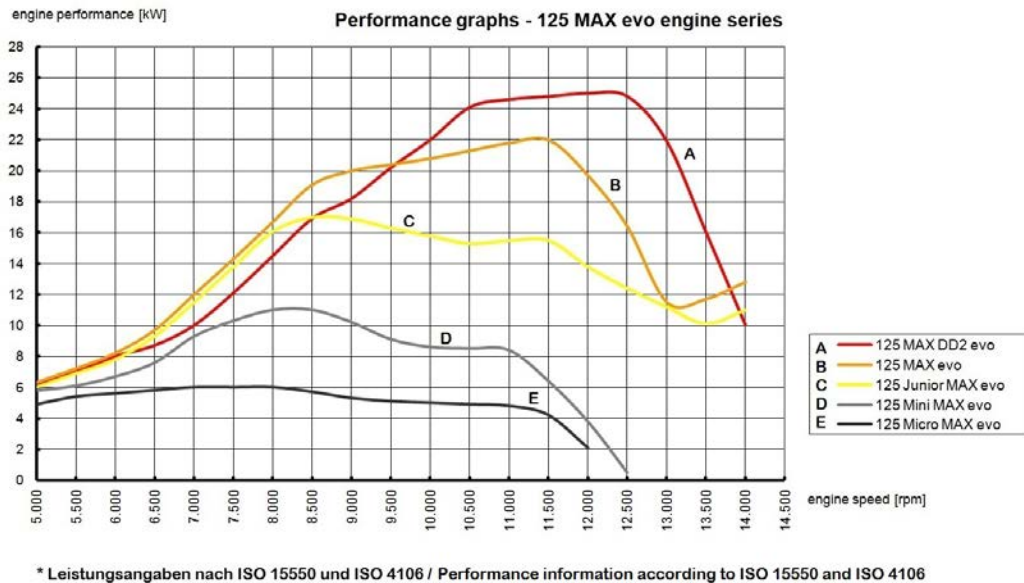

Figure 3.1: Performance graphs

CARBURETOR CALIBRATION

The standard carburetor calibration is for an ambient temperature of 25 °C / 77 °F and 400 m / 1310 ft above sea level. At operation with different temperatures and altitudes, the main jet of the carburetor has to be changed in accordance with Table 1, to optimize engine performance.

NOTE

For engine operation at an ambient temperature below 10 °C / 50 °F, make sure not to demand full power before the coolant temperature has reached 45 °C / 113 °F.

NOTE

The warranty by BRP-Rotax will no longer apply, if the carburetor calibration is carried out improperly and causes engine damage.

The following application for smartphones shows the individual setting of your ROTAX® 125 Max DD2 evo engine:

The ROTAX® Max Jetting Guide is an App for Android™ and iOS devices, designed to assist users with setting up the recommended main jet based on the ambient conditions and the type of engine. The perfect set-up can be calculated in two ways, either automatically - which requires a GPS signal and an internet connection, or manually - which requires certain knowledge about altitude and weather conditions.

BRP-Rotax Operators Manual

AUTOMATIC-SET-UP

Step	Procedure
1	Click on the white button located at the top of the screen saying "USE GPS POSITION FOR WEATHER DATA". After a short time the app will automatically provide all the necessary information regarding weather and geographical position.



Figure 3.2

Step	Procedure
2	As a second step, the engine type of the kart needs to be selected. Therefore, the button underneath the weather data needs to be clicked. The app will automatically show all potential Max evo engines, from which one can be selected by clicking on a certain engine type.

BRP-Rotax Operators Manual

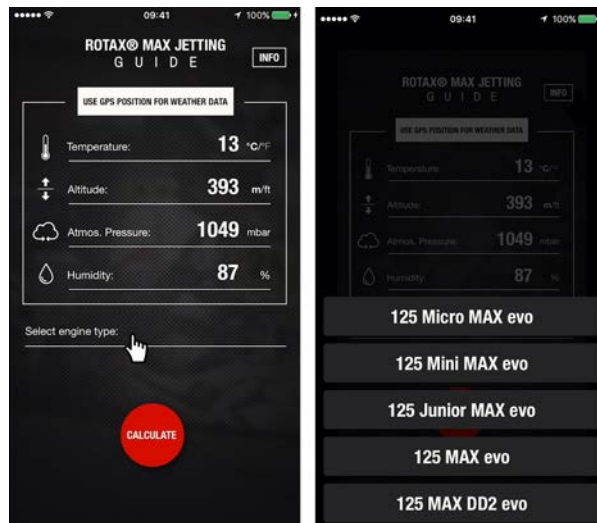

Figure 3.3

Step	Procedure
3	After all the necessary information has been provided and selected, you only need to click the circular red button saying “CALCULATE” at the bottom of the screen.

BRP-Rotax Operators Manual



Figure 3.4

Step	Procedure
4	Now the recommended main jet value will be provided. In case a second calculation needs to be made, you can start over by simply pressing the button saying "RESET" next to the calculated value.

BRP-Rotax Operators Manual



Figure 3.5

MANUAL SET-UP

Step	Procedure
1	In case no GPS signal or internet connection is available, the necessary data needs to be added manually, which of course requires knowledge about current weather conditions at the race track as well as the altitude. By clicking on the empty space next to “Temperature”, “Altitude”, “Atmos. Pressure” and “Humidity”, you are able to enter the required information. In terms of “Atmos. Pressure”, the atmospheric pressure at sea level has to be entered, usually the barometer shows the actual level.
2	As a second step, the engine type of the kart needs to be selected. Therefore, the button underneath the weather data needs to be clicked. The app will automatically show all potential Max evo engines, from which one can be selected by clicking on a certain engine type.
3	After all the necessary information has been provided and selected, you only need to click the circular red button saying “CALCULATE” at the bottom of the screen.
4	Now the recommended main jet value will be provided. In case a second calculation needs to be made, you can start over by simply pressing the button saying “RESET” next to the calculated value.

BRP-Rotax Operators Manual

Additional Information

- In case values are being entered manually, the provided numbers will turn from white to red if they are considered to be unrealistic.
- Depending on their preference, users can decide if they would like to use the metric or the imperial system. You can change between Celsius and Fahrenheit by simply clicking on the small °C or °F next to the value for temperature. The same works with feet and meter, where you can just click on the small m or ft located next to the value for altitude in order to change between the systems.

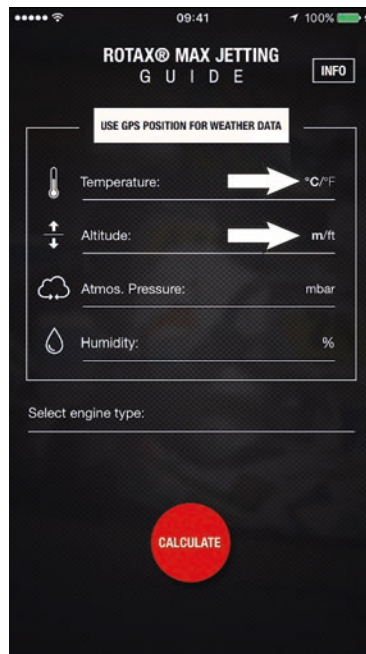

Figure 3.6

- In the top right corner, you can find a button called "INFO". By clicking this button, additional information about the app as well as setting up the carburetor like float height, position of the jet needle or the air adjustment screw can be found. By clicking the small red X underneath the info button, you can return to the home screen.

BRP-Rotax Operators Manual

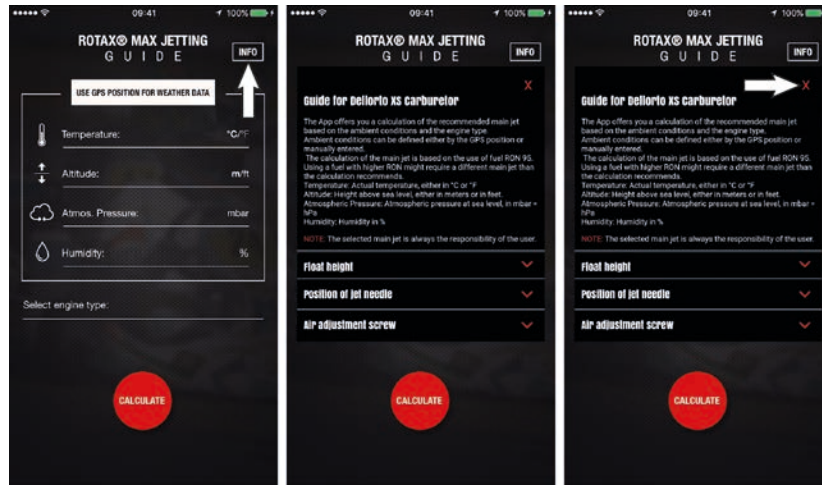

Figure 3.7

Please scan the following QR-code for a detailed instruction video:



Figure 3.8: QR- code

App Download

Please scan the following QR-code for your mobile device:



Figure 3.9: QR- code, Android device



Figure 3.10: QR- code, iOS device

For better understanding and as help for carburetor adjustment, the following figure describes the effect of the various adjustments, depending on the throttle position.

BRP-Rotax Operators Manual

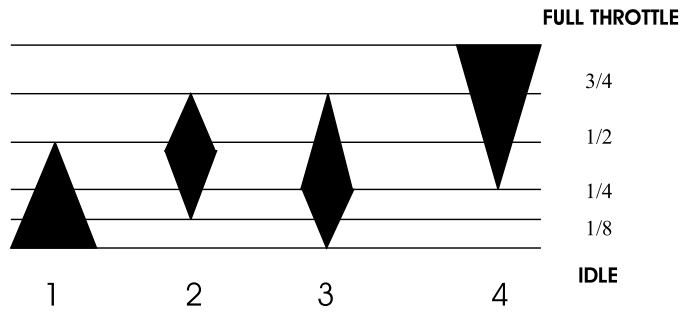

1 - AIR SCREW AND PILOT JET

2 - TYPE AND POSITION OF JET NEEDLE

3 - TYPE OF NEEDLE JET

4 - MAINJET

Figure 3.11: Various adjustments

BRP-Rotax Operators Manual

CHANGE OF THE CARBURETOR MAIN JET

To change the carburetor main jet, proceed as follows:

Tools required:

- Open-end wrench 19 mm
- Flathead screwdriver

NOTE

The carburetor must not be removed from the engine in order to change the jetting.

⚠ WARNING

Non-compliance can result in serious injuries or death!
Handle fuel in well-ventilated areas only.

⚠ WARNING

Non-compliance can result in serious injuries or death!
When handling with fuel, do not smoke or allow open flames. Gasoline and gasoline vapor are highly flammable and explosive under certain conditions.

⚠ WARNING

Risk of fire and explosion!
Make sure that fuel will not splash onto hot engine components or equipment.

ENVIRONMENTAL NOTE

Don't spill fuel. Absorb spilled fuel with appropriate drying agent and ensure ecological disposal.

Step	Procedure
1	Drain the fuel in the float chamber into a suitable clean tray by removing the plug screw (pos. 27) and gasket ring (pos. 26). NOTE <i>The fuel drained from the float chamber may be poured back into the fuel tank.</i>
2	Remove the main jet (pos. 15) and the main jet cup (pos. 14). NOTE <i>The size of the jet is imprinted on the face of the main jet.</i>

BRP-Rotax Operators Manual

Step	Procedure
3	Select the appropriate size of main jet, refer to ROTAX® Max Jetting Guide.
4	Install the main jet cup (pos. 14) in position and fit the corresponding main jet (see ROTAX® Max Jetting Guide).
5	Fit and hand-tighten the plug screw (pos. 27) and gasket ring (pos. 26).

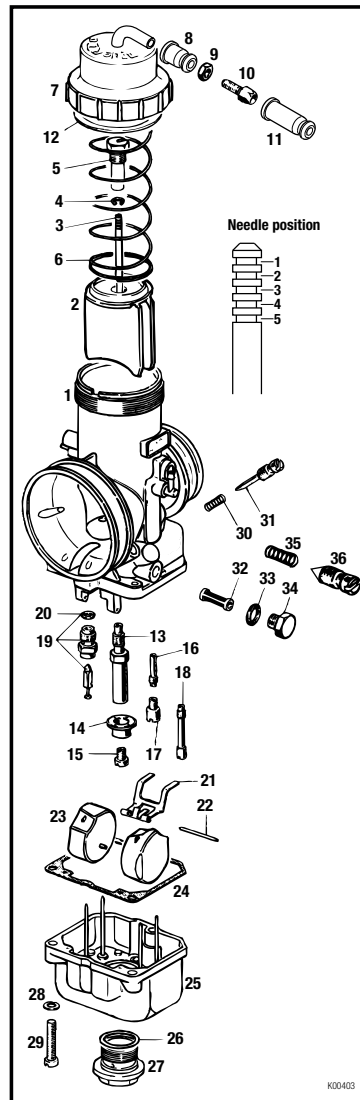

Figure 3.12: Components of carburetor

BRP-Rotax

Operators Manual

NOTE

In a disassembled carburetor, the position of the jet needle (pos. 3) can be changed. The standard position of the jet needle is 'position 2'. If the clip (pos. 4) is set in 'position 1' of the jet needle, the full mixture in part and full-load will become slightly leaner. If the clip (pos. 4) is set into 'position 5', the fuel mixture will become slightly richer in the part and full-load range.

NOTE

The fuel filter (pos. 32) is located below the fuel inlet on the carburetor, preventing contamination from entering the carburetor, which could impair operation of the carburetor.

Step	Procedure
6	Remove the hex. screw (pos. 34) and gasket ring (pos. 33).
7	Pull out the fuel filter (pos. 32) and clean the filter and fuel inlet.
8	Refit the fuel filter (pos. 32), the gasket ring (pos. 33) and hex. screw (pos. 34).

NOTE

When trying to start the engine it, will take a few seconds for the fuel pump to fill the float chamber and for the engine to start.

NOTE

With the adjustment screw (pos. 36), the idle speed of the engine can be adjusted. By turning in the adjustment screw (pos. 36) the idle speed increases and by turning out the screw (pos. 36) the idle speed will be reduced.

NOTE

With the adjustment screw (pos. 31), the fuel mixture formation can be adjusted. By turning in the adjustment screw (pos. 31), the air-fuel mixture will become richer at idling and by turning out the screw (pos. 31), the air-fuel mixture will become leaner at idling. The default setting of the adjustment screw are two full turns and one quarter of a turn (2 ¼) from inside to outside.

BRP-Rotax Operators Manual

CHOOSE OF GEAR RATIO

In spite of its 2 gears, the 125 MAX DD2 evo engine offers a broad performance band. Therefore, the frequent changing of the primary gear ratio is not necessary.

NOTE

It is not possible to change the 1st and 2nd gear individually.

On most of the Kart circuits you will be well served with the standard gear ratio (35/62 which is equivalent to 12/90 for 1st gear and 14/79 for 2nd gear). If due to the special shape of the circuit (e.g. extremely sharp corners or long straights), it is deemed necessary, the primary gear ratio can be changed both, a shorter or a longer ratio.

If the rpm. range from 9.200 to 12.200 rpm. is not sufficient because of a particular track shape (extremely long straight), the maximum engine speed of 13.600 rpm. should be aimed for.

NOTE

A basic requirement for the full use of the speed range between 12.200 to 13.600 rpm. is optimized carburetor jetting (see chapter 4.1. Carburetor calibration).

The acceleration potential between 9.200 and 12.200 rpm. is essentially higher than between 12.200 and 13.600 rpm. Therefore, it does not always make sense to use this rpm. range (high top speed on a straight) and to not take advantage of the acceleration potential of the lower rpm. range (out of sharp corners).

This is a suggestion. The optimum choice can only be found with the exact knowledge of the race track.

To approach and optimize the reduction gear ratio, the following charts should be helpful. The optimization procedure regarding the reduction gear ratio for a new race track is explained step by step by the following example:

Procedure
Start with the standard gear ratio (35/62, equivalent to 12/90 at 1 st gear and 14/79 at 2 nd gear).

Based on the following criteria, you must decide, whether a shorter or longer gear ratio is necessary.

Does the engine reach 12.500 rpm in 2nd gear at the end of the longest straight?

IF YES, proceed as follows

Procedure
Choose the next longer gear ratio (36/61 equivalent to 12/87 in 1 st gear and 14/76 in 2 nd gear).

IF NO, proceed as follows

Procedure
Choose the next shorter gear ratio (34/63 equivalent to 11/87 in 1 st gear and 14/83 in 2 nd gear).

BRP-Rotax

Operators Manual

If these gear ratios are still not sufficient, try the next shorter or next longer gear ratio.

NOTE

When using short gear ratios, it may happen that the response behavior of the engine in 1st gear is aggressive and the vehicle handling becomes difficult. For a good lap time, often a longer gear ratio is helpful to achieve reasonable performance behavior.

NOTE

To help with the choice of adequate gear ratios, the two charts below illustrate the traditional gear ratios and the top speeds in [kmh] that can be reached in the respective gear at an engine speed of 12.500 rpm.

Gear ratio 1 st gear				
Number of teeth of primary drive gear	Number of teeth of secondary drive gear	Gear ratio	Traditional gear ratio (in sprocket size)	Theoretical max. speed (in km/h / mile/h) (at 12.500 rpm and wheel diameter 870 mm /34.25 in.)
32	65	8.65	10 to 87	75 / 47
33	64	8.26	11 to 91	79 / 49
34	63	7.89	11 to 87	83 / 52
35	62	7.55	12 to 90	86 / 53
36	61	7.22	12 to 87	90 / 56
37	60	6.91	12 to 83	94 / 58
38	59	6.61	12 to 80	99 / 62

gear ratio of 1 st gear (cannot be changed)	4.26
--	------

Gear ratio 2 nd gear				
Number of teeth of primary drive gear	Number of teeth of secondary drive gear	Gear ratio	Traditional gear ratio (in sprocket size)	Theoretical max. speed (in km/h / mile/h) (at 12.500 rpm and wheel diameter 870 mm /34.25 in.)
32	65	6.52	14 to 91	100 / 62
33	64	6.23	14 to 87	105 / 65
34	63	5.95	14 to 83	110 / 68
35	62	5.69	14 to 79	115 / 72

BRP-Rotax Operators Manual

Gear ratio 2 nd gear				
Number of teeth of primary drive gear	Number of teeth of secondary drive gear	Gear ratio	Traditional gear ratio (in sprocket size)	Theoretical max. speed (in km/h / mile/h) (at 12.500 rpm and wheel diameter 870 mm /34.25 in.)
36	61	5.44	14 to 76	120 / 75
37	60	5.21	14 to 73	125 / 78
38	59	4.98	15 to 75	131 / 81

gear ratio of 2 nd gear (cannot be changed)	3.21
--	------

NOTE

To facilitate the change of gear ratio, it is recommended to carry a clutch drum with a primary drive gear and the respective secondary gear for each gear ratio.

NOTE

To allow easier matching of primary and secondary gears, please note that the sum of the last digits of the teeth number must always be 7 or 17 (35 / 62).

EXCHANGE OF GEAR REDUCTION RATIO

Tools required:
<ul style="list-style-type: none"> • Torque wrench • Allen key 5 mm • Allen key 6 mm

At first glance, the exchange of the gear ratio seems to be more complicated than you are used to. If, however, you follow the hints below, you will notice that the work involved is not much different.

Step	Procedure
1	Lift engine side of the kart and place the vehicle on a trolley.
2	Remove the right rear hub with wheel.
3	<p>Unscrew 4 Allen screws M6x30 (pos. 1), 4 Allen screws M8x70 (pos. 2) and 2 Allen screws M6x40 (pos. 3). Remove the gear cover.</p> <p>NOTE</p> <p><i>If the gear cover is difficult to remove, it can be levered off at the separating lugs.</i></p>

BRP-Rotax Operators Manual

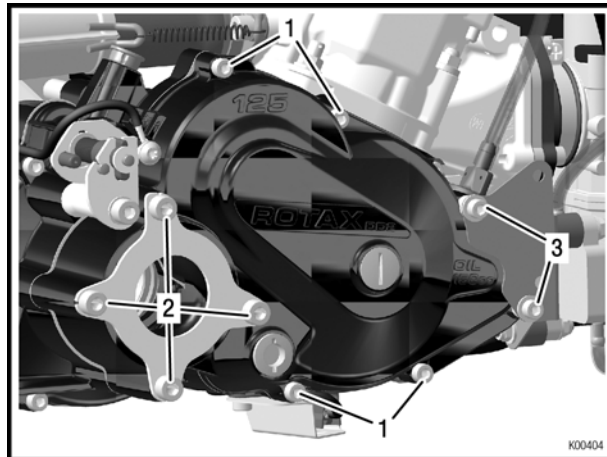

Figure 3.13: Gear cover

Step	Procedure
4	Remove the primary drive gear (pos. 4) and secondary gear (pos. 5) and fit the gear pair of your choice. NOTE <i>At re-assembly, proceed in reverse sequence. Tighten the screws to the following torque settings: M6: 10 Nm (88 lbf. in.) / M8: 22 Nm (195 lbf. in.)</i>

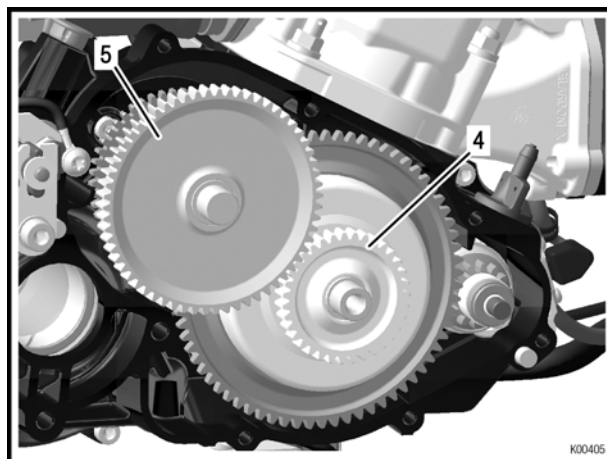

Figure 3.14: Gear ratio

OPERATION OF THE GEAR BOX

The ROTAX® 125 MAX DD2 evo is fitted with a 2-speed gearbox that is changed manually via a shifting device. The engine also has an electronic ignition cut-off which when changing from 1st to 2nd gear, interrupts the ignition, relieving the load from the gearbox and thereby makes gear shifting easier and faster.

NOTE

Gear shifting might not be possible when the engine is not running as it is not assured that the gear engages.

In principle, the gear shifting is very simple, only some points have to be observed:

Engagement of the 1st gear

ATTENTION

It is prohibited, to rev the engine up in idle mode in order to change engage the 1st gear. This could lead to engine failure.

Shifting from 1st to 2nd gear

- In principle, this is possible at any engine speed (rpm.). The optimum timing for shifting is at about 12.200 1/min.
- Due to the electronic ignition cut-off, the gas pedal can stay fully activated during the shifting operation.

Shifting from 2nd to 1st gear

- Due to the high difference in rpm. between the two gears, it is not recommended to shift down at a speed of over 10.200 rpm.

ADJUSTMENT OF GEAR SHIFTING

The perfect functioning of gear shifting depends to a great extent on the correct adjustment of the gear shifting mechanism.

NOTE

When the engine is not running, it may not be possible to engage gears, depending on the position between shifting sleeve and idle gear of the first or second gear. In this case, turn the rear axle until you find a position allowing gears to engage.

Step	Procedure
1	<p>Check, whether the shift paddle aligns with the steering wheel when in „NEUTRAL“. If this is not the case, correct the Bowden cable accordingly.</p> <p>NOTE</p> <p><i>For adjustment of gear shifting, please follow the instruction of the chassis manufacturer.</i></p> <p>NOTE</p> <p><i>If the gearshift cables are excessively tensioned, the gears are hard to shift.</i></p>
2	<p>The distance between shift contact and screw head at the gearshift shaft must be 1,0 – 1,5 mm / 0.04 – 0.06 in. The distance can be adjusted by turning the Allen screw (pos.1) in or out. See Fig. “Adjusted”</p> <p>NOTE</p> <p><i>If the distance between shift contact and screw head is not correctly adjusted, the function of the ignition cut-off is not assured. This may cause gear shifting problems.</i></p> <p>NOTE</p> <p><i>If changing the gear becomes difficult after some operating hours, check , whether the retaining plate is bent, replace it with a new one or try to bend the support back into the correct position.</i></p>

BRP-Rotax Operators Manual

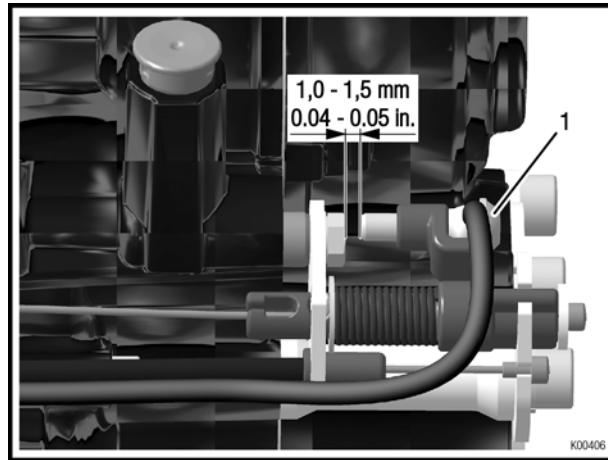

Figure 3.15: Adjusted

BRP-Rotax
Operators Manual

Chapter: 4
ENGINE OPERATION

TOPICS IN THIS CHAPTER

ENGINE OPERATING	2
Engine start	2
Stopping the engine.....	4
Running – in procedure for the engine.....	5
Setting of the exhaust valve timing	6
Maintenance schedule for engine components	9
Operating Limits.....	11

ENGINE OPERATING

ENGINE START

Before starting the engine, make sure you have completed all necessary tasks for running the engine:

- ✓ Fuel tank full.
- ✓ Battery charged and connected.
- ✓ Battery voltage over 12 V.
- ✓ Carburetor Bowden cable is moving freely and carburetor piston connected in idle position.
- ✓ For safety reasons, it's recommended to put the shifting device in "**Neutral**" (no gear engaged).

At engine start proceed as follows:

Step	Procedure
1	On a cold engine, pull the choke lever (pos. 1,) into a vertical position.

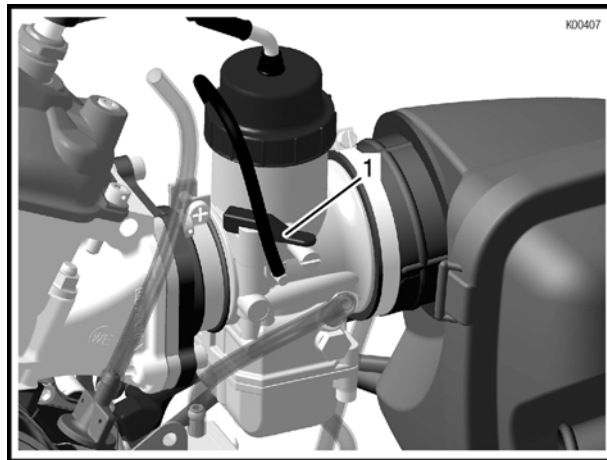

Figure 4.1: Choke lever

Step	Procedure
2	Press the power button once, the ignition system is activated (light turns on). Press the button again until the engine starts. See Fig. "Power button" NOTE <i>If the engine does not start, repeat the operation after a few seconds in the same manner.</i>

BRP-Rotax Operators Manual

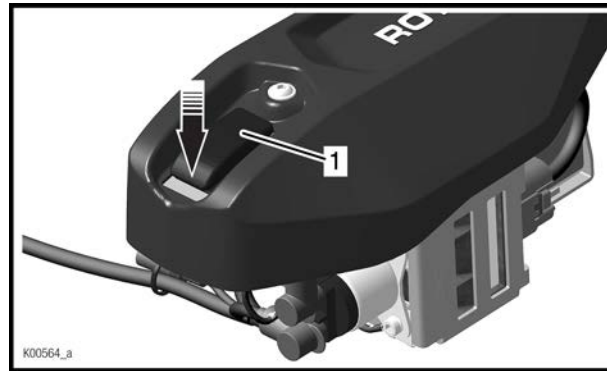

Figure 4.2: Power button

Step	Procedure
3	After engine start, take choke back until engine idles smoothly without choke.

⚠ WARNING

Non-compliance can result in serious injuries or death!

Always wear protective clothing for kart operation (helmet, overall, gloves, shoes, neck and rib guards).

⚠ WARNING

Non-compliance can result in serious injuries or death!

Do not touch the engine, the radiator or the exhaust system during and immediately after kart operation. Risk of burning!

⚠ WARNING

Non-compliance can result in serious injuries or death!

During kart operation, beware of body or clothing contact with moving components of the kart.

⚠ WARNING

Non-compliance can result in serious injuries or death!

Comply with the safety advice of the engine and kart manufacturer.

⚠ WARNING

Non-compliance can result in serious injuries or death!

Inspect any part prone to wear (tyres, bearings etc.) before each kart event for good condition, in accordance with the directives of the kart manufacturer.

BRP-Rotax Operators Manual

ATTENTION

Non-compliance can result in engine damage!
Keep to running-in procedure as directed.

⚠ WARNING

Non-compliance can result in serious injuries or death!
Operate engine only within the specified limits.

⚠ WARNING

Non-compliance can result in serious injuries or death!
Only get in and out of the kart if engine is not running.

STOPPING THE ENGINE

See Fig. [Power button](#)

Step	Procedure
1	Press the power button and the engine will stop.

NOTE

If electric starter is activated, the ignition system will consume current. This can cause a deep discharge and damage to the battery.

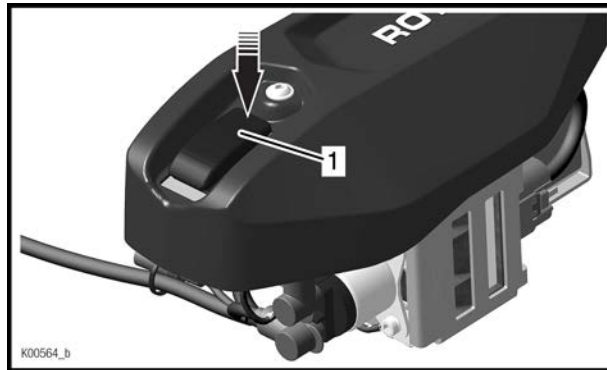

Figure 4.3: Power button

1 Power button

RUNNING – IN PROCEDURE FOR THE ENGINE

⚠ WARNING

Non-compliance can result in serious injuries or death!
Pay attention to the safety advice of the kart manufacturer.

To ensure that components have the longest possible lifespan, the engine must undergo a defined running-in period at first operation or after a repair of the crankshaft or displacement parts.

NOTE

Cover the radiator with the mounted windshield to reach the operating temperature earlier.

Make sure following requirements are fulfilled:

- ✓ Use a long gear ratio (standard or higher).
- ✓ Use our JETTING APP and choose a 1 to 2 number bigger sized main jet than recommended.
- ✓ For the first 10 liters of fuel use a mixing ratio of 1:33 (= 3% or 0.3 liter oil per 10 liters fuel).
- ✓ Make sure that the coolant temperature reaches 45 °C (113 °F) before going full throttle.
- ✓ Run the kart for 15 minutes at continuously changing load and engine speed fluctuation up to maximum rotational speed. Rotational speed for max. 2 seconds!
- ✓ Afterwards reduce the main jet size step by step until standard size is reached.

After this running-in procedure, the full power of the engine may be used.

ATTENTION

Use only fully synthetic 2-stroke oil.
BRP-Rotax recommends the use of XPS Kart Tec oil.

ATTENTION

The engine may never be operated without load.
Is it operated without load (i.e. on the trolley) rpm. over 13.800 1/min are possible, which shortens the life time of components (con rod, big end bearing etc).

SETTING OF THE EXHAUST VALVE TIMING

Tools required:
<ul style="list-style-type: none">• Allen key 4 mm or Socket wrench 8 mm

The opening time of the exhaust valve is set in the ECU and depends on the engine speed. However, the ECU allows two different modes of the exhaust valve opening. These can be selected by connecting an additional cable to the cylinder head cover.

ATTENTION
The ground wire must be continuously connected. This is important for the general function of the engine.

Variant 1: Additional cable on battery ground

A:

See [Ground wire](#)

The additional cable is **NOT** attached to the ground wire. The control of the exhaust valve timing is activated at 9100 rpm.

NOTE

Isolate the additional cable with an electrical/insulating tape to the ground wire so that a possible contact with the engine ground does not affect the function.

B:

See [Ground wire](#)

The additional cable is attached to the ground wire. The control of the exhaust valve timing is activated at 8800 rpm.

BRP-Rotax Operators Manual

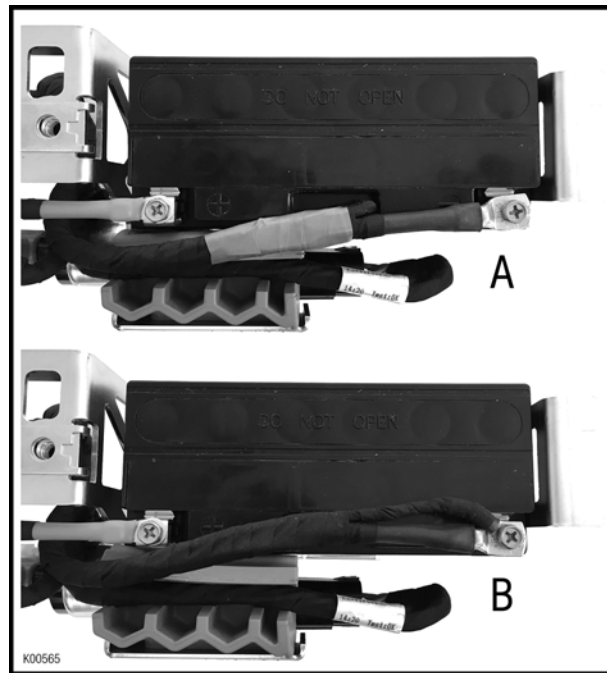

Figure 4.4: Ground wire

Variant 2: Additional cable on starter relay

A:

See [Cable on starter relay](#).

The additional cable is **NOT** attached to the ground wire. The control of the exhaust valve timing is activated at 9100 rpm.

NOTE

Isolate the additional cable with an electrical/insulating tape to the ground wire so that a possible contact with the engine ground does not affect the function.

B:

See [Cable on starter relay](#).

The additional cable is attached to the ground wire. The control of the exhaust valve timing is activated at 8800 rpm.

BRP-Rotax
Operators Manual

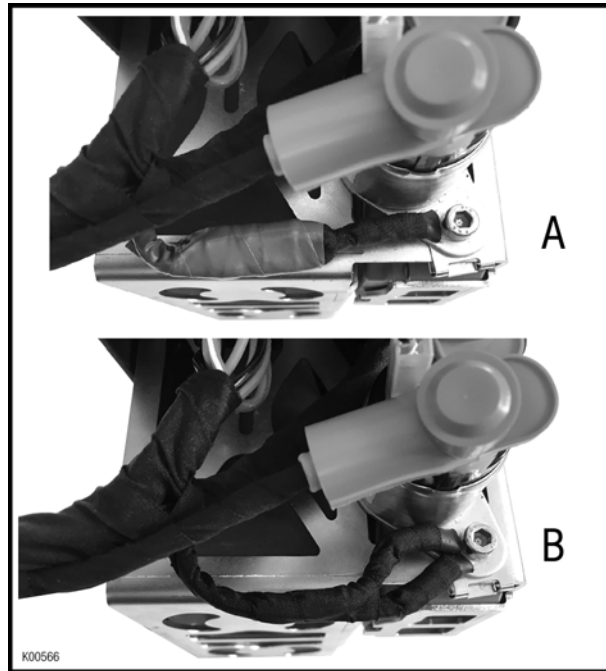

Figure 4.5: Cable on starter relay

NOTE

Either variant 1 or variant 2 has been installed in your engine.

BRP-Rotax
Operators Manual

MAINTENANCE SCHEDULE FOR ENGINE COMPONENTS

ATTENTION

Non-compliance with the specified maintenance schedule could result in engine damage.

ENGINE	FREQUENCY						NOTES
	Before every operation	After every operation	Every 2 hours of operation	Every 5 hours of operation	Every 10 hours of operation	Every 50 hours of operation	
Check oil level in gearbox			X				
Exchange oil in gearbox							after first 5 hours of operation, then inspect the oil every 5 hours and change it if necessary
Clean exhaust valve and check if moving freely				X			
Check overflow bottle, empty if needed	X						
Tear-down inspection of engine (must be conducted by an authorized ROTAX® Service Center)						X	Inspect following components and replace if requested: piston, piston pin and piston pin bearing, conrod and conrod bearing, main bearings of crankshaft.
Clean airfilter, apply oil, replace in case of visible damage				X			after each rainy session, use air filter cleaner kit
Visually inspect connections between engine and carburetor and check fit and tightness of intake silencer	X						right after every collision
Visually inspect fuel filter regarding dirt, replace if needed	X						
Replace fuel filter						X	

BRP-Rotax
Operators Manual

ENGINE	FREQUENCY						NOTES
	Before every operation	After every operation	Every 2 hours of operation	Every 5 hours of operation	Every 10 hours of operation	Every 50 hours of operation	
Renew damping material in after muffler of exhaust system				X			
Check fit and tightness of exhaust	X						
Inspect for oil or water on the leakage bore at the crankcase	X						right after every collision
Verify a tight fit and non leakage of radiator hoses and clamps at engine and radiator	X						right after every collision
Replace spark plug						X	as requested
Dirt catching groove on secondary gear					X		
Overload clutch inspection	X						
RAVE			X				Clean hoses with compressed air.

BRP-Rotax

Operators Manual

OPERATING LIMITS

Operating the engine is only permitted under following conditions:
Recommended coolant temperature rang: 45 °C – 85 °C (113 °F – 185 °F).

ATTENTION

Operating the engine at a too low temperature could result in piston seizure.
The engine is only allowed to be run at peak performance after reaching the specified operating temperature.

NOTE

If the engine does not reach the minimum specified operating temperature due to the low ambient temperature, then the cooling efficiency of the radiator must be reduced by partially covering the radiator with adhesive tape.

⚠ WARNING

Non-compliance can result in serious injuries or death!
The maximum operating temperature of the engine must not be exceeded. If the temperature is too high, it may result in piston seizure.

NOTE

Dirt must be cleared from the lamination of the radiator at regular intervals to achieve the best cooling performance.

BRP-Rotax
Operators Manual

NOTES

Chapter: 5
PRESERVATION AND TRANSPORT

TOPICS IN THIS CHAPTER

Preservation and transport	2
Preservation of engine and equipment	2
Transport of the kart.....	2
IMPORTANT INFORMATION (SUMMARY).....	3
Notes	4

PRESERVATION AND TRANSPORT

PRESERVATION OF ENGINE AND EQUIPMENT

For longer periods out of operation (winter time), make sure that the engine will be properly preserved.

Step	Procedure
1	Detach carburetor, drain fuel from carburetor and close carburetor openings to ensure that no dust or dirt can enter.
2	If the vehicle gets stored at temperatures below freezing, drain the entire cooling system and clean the cooling circuit with pressure air.

⚠ WARNING

Not following this may lead to engine damage.

Step	Procedure
3	Close intake and exhaust port of engine with adhesive tape so that they are airtight.
4	Apply oil on exhaust system to prevent corrosion.
5	Remove battery from the fixture and charge periodically with the specified battery charger.

TRANSPORT OF THE KART

If the carburetor is still filled with fuel, the kart is only allowed to be transported in a horizontal position.

If the kart is to be transported in a vertical position, the fuel must be drained from the carburetor first.

NOTE

If the kart is in a vertical position at transport, the remaining fuel in the carburetor might flow into the crankcase with the result that the engine won't start at next try.

Step	Procedure
1	Remove drain screw on float chamber of carburetor and collect the fuel in a suitable container.
2	Clean drain screw and refit.

BRP-Rotax
Operators Manual

IMPORTANT INFORMATION (SUMMARY)

IMPORTANT INFORMATION	Liter	GAL.	SPECIFICATION	RECOMMENDED BRANDS
FUEL			Unleaded fuel of minimum octane level of 95 ROZ resp. 91 MOZ	
2-STROKE OIL			Fully synthetic	XPS Kart-Tec
OIL IN FUEL MIX-ING RATIO			During break-in: 1:33 (=3% oil) During normal use: 1:50 (=2% oil)	
COOLING SYSTEM	0.90	0.237	Pure water resp. antifreeze if kart is stored at temperatures below 0 °C/ 32 °F	
GEARBOX OIL	0.150	0.039	Engine oil SAE 15W-40	XPS Kart-Tec
SPARK PLUG			see IPC	NGK

BRP-Rotax
Operators Manual

Index

A

Adjustment of gear shifting.....	19
Automatic-set-up.....	4

B

Balance gear	3
Battery and battery charging unit.....	3
Battery charging unit	4

C

Carburetor	4
Carburetor calibration	3
Centrifugal clutch	5
Change of the carburetor main jet.....	11
Choose of gear ratio	14
Coolant	2
Cooling circuit.....	2

D

Design of the ROTAX engine 125 MAX DD2 evo	2
--	---

E

Electric starter.....	3
Electro pneumatically exhaust timing control	3
Electronic Shifting Assistant (ESA)	4
Engine calibration	2
Engine operating.....	2
Engine operation.....	1
Engine start	2
Exchange of gear reduction ratio	16
Exhaust system	4

F

Fuel	6
Fuel pump	4

G

Gearbox	4
---------------	---

General	2
---------------	---

I

Ignition unit.....	3
IMPORTANT INFORMATION (SUMMARY).....	3
Intake silencer	3
INTRO	1

M

Maintenance schedule for engine components	9
Manual set-up.....	7

N

NOTES	4
-------------	---

O

Operating limits.....	11
Operation of the gear box	18
Overload clutch.....	5

P

Performance graphs.....	2
Preservation and transport.....	2
Preservation of engine and equipment.....	2

R

Running – in procedure for the engine	5
---	---

S

Setting of the exhaust valve timing.....	6
Stopping the engine	4

T

Technical Description	1
Transport of the kart	2

ROTAX[®]
KARTING

