

# REPAIR MANUAL

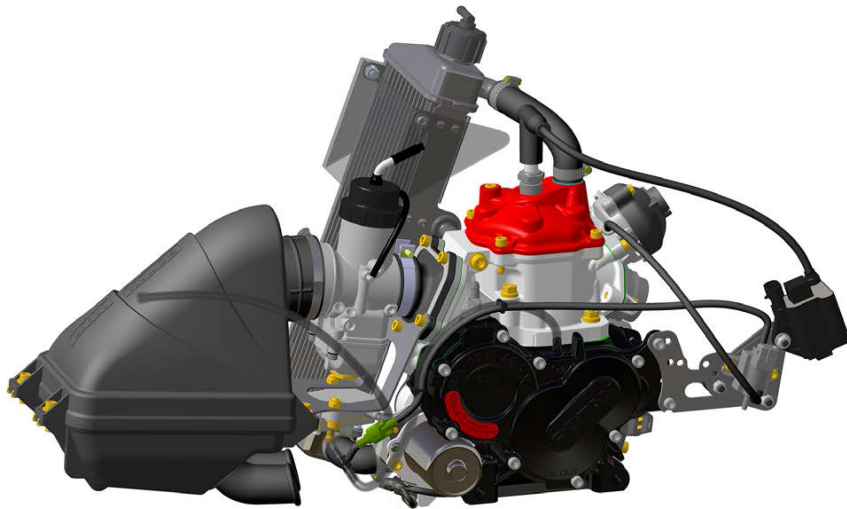

*for ROTAX<sup>®</sup>-engines type*

**125 MAX evo**

**125 JUNIOR MAX evo**

**125 MINI MAX evo**

**125 MICRO MAX evo**

Part no. 298061

**BRP-Rotax**  
**REPAIR MANUAL**

**Chapter: INTRO**  
**GENERAL INFORMATION**

- Preface** Before carrying out repair work on the engine, read the Repair Manual carefully. If any passages of the Manual are not clearly understood or if you have questions, please contact an authorized Distribution or Service Center for ROTAX®-kart engines.
- Contents** This Repair Manual contains instructions for all the necessary repair and maintenance work on the ROTAX®-Engine Type 125 MAX evo, 125 Junior MAX evo, 125 Mini MAX evo and 125 Micro MAX evo.
- Symbols used** This Manual uses the following symbols to emphasize particular information. This information is important and must be observed.

**⚠ WARNING**

**Identifies an instruction, which if not followed may cause injury or endanger the life of the driver, mechanic or third party.**

**ATTENTION**

**Denotes an instruction which if not followed may severely damage the engine. Noncompliance might lead to health hazards under certain conditions.**

**ENVIRONMENTAL NOTE**

**Environmental notes give you tips on environmental protection.**

**NOTE**

*Indicates supplementary information which may be needed to fully complete or understand an instruction.*

✓ Denotes a checking operation

**TIP** This information gives you additional advice and tips

**BRP-Rotax**  
REPAIR MANUAL

NOTES

**BRP-Rotax  
REPAIR MANUAL**

**Chapter: Chapter 1  
GENERAL NOTE**

**TOPICS IN THIS CHAPTER**

<b>Abbreviations and terms used in this Manual</b> .....	<b>3</b>
<b>Safety</b> .....	<b>4</b>
Safety notice .....	4
Instruction .....	5
Technical documentation.....	6
Use for intended purpose .....	6
<b>Technical data</b> .....	<b>7</b>

# BRP-Rotax REPAIR MANUAL

- Purpose** This Repair Manual is based on information and the state-of-knowledge of BRP-Rotax of the product current at the date of issue.
- Documentation** For additional information on engines, maintenance or parts, you can also contact your nearest authorized ROTAX®-Engine distributor.
- ROTAX® distributors** ROTAX® Authorized Distributors for Kart Engines. See on web at the official Homepage <http://www.rotax-kart.com>.
- Engine serial number** If you have any concerns or questions, always keep your engine serial number ready for questions from your dealer, as the manufacturer makes modifications to the engine for product improvement. The engine number is stamped on the clutch side housing half. See Figure 1.

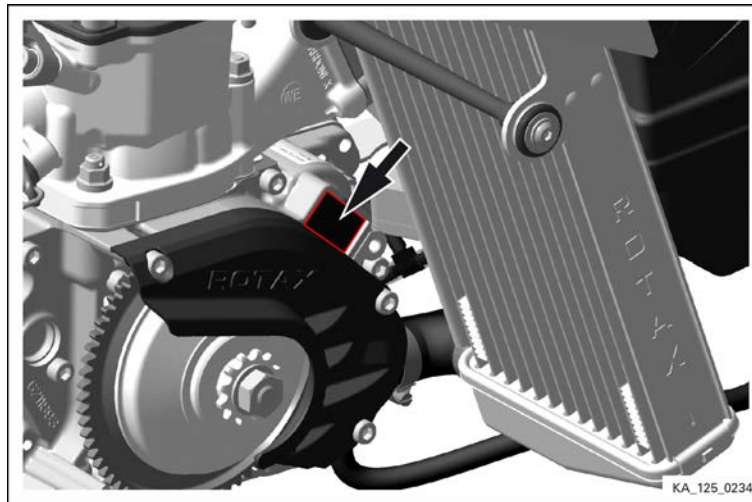

Figure 1.1: Position of the engine serial number

**BRP-Rotax**  
**REPAIR MANUAL**

**ABBREVIATIONS AND TERMS USED IN THIS MANUAL**

**Abbreviations**

<b>Abbreviations</b>	<b>Description</b>
°C	Degree Celsius (Centigrade)
°F	Degree Fahrenheit
rpm	Revolutions per minute
125 MAX evo	see Manual (Type designation)
125 Junior MAX evo	see Manual (Type designation)
125 Mini MAX evo	see Manual (Type designation)
125 Micro MAX evo	see Manual (Type designation)
INTRO	Introduction
IPC	Illustrated Parts Catalog
h	hours
OM	Operators Manual
kg	kilograms
MON	Motor Octane Number
n.a.	not available
Nm	Newton meter
Rev.	Revision
RON	Research Octane Number
RM	Repair Manual
S/N	Serial Number
SI	Service Instruction
SL	Service Letter
part no.	Part number
V	Volt

# BRP-Rotax REPAIR MANUAL

## SAFETY

- General note** Although the reading of such information does not eliminate the hazard, the understanding the information will promote its correct use. Always take care by conducting manual work and use safety equipment. The information and components-/system descriptions contained in this Manual are correct at the time of publication. BRP-Rotax, however, maintains a policy of continuous improvement of its products without imposing upon itself any obligation to install them on its products previously manufactured.
- Revision** BRP-Rotax reserves the right at any time, and without incurring obligation, to remove, replace or discontinue any design, specification, feature or other details.
- Specifications** Specifications are given in the SI metric system with the USA equivalent in parenthesis.

## SAFETY NOTICE

### General note

#### **WARNING**

**Non-compliance can result in serious injuries or death!**  
Comply with the safety advice of the engine and kart manufacturer.

This information relates to the preparation and use of ROTAX® Kart engines and has been utilized safely and effectively by BRP-Rotax. However, BRP-Rotax disclaims liability for all damage and/or injuries resulting from the improper use of the contents. BRP-Rotax strongly recommend that any service be carried out and/or verified by a highly skilled professional mechanic.

- Manual** This Manual has been prepared as a guide to correctly service and maintain all ROTAX® Kart engines.  
This Manual uses technical terms which may be slightly different from the ones used in the Illustrated Parts Catalog.  
It is understood that this Manual may be translated into another language. In the event of any discrepancy the English version prevails.
- Warning** It is your responsibility to be completely familiar with the safety instructions including warnings and cautions described in this Manual. These warnings and cautions advise of specific operating and servicing methods that, if not observed, can cause a serious engine malfunction or cause the engine to lose power which can result in serious injury, damage to equipment or even to death.  
It is, however, important to understand that these warnings and cautions are carefully checked. BRP-Rotax can not evaluate and advise the user of all conceivable ways in which service might be done or of the possible hazardous consequences that may occur.
- Safety instruction** In addition to observing the instructions in our Manual, general safety and accident preventative measures, legal regulations and regulations of any superior authority must be observed.  
Where differences exist between this Manual and regulations provided by any authority, the more stringent regulation should be applied.

# BRP-Rotax REPAIR MANUAL

**Illustration** The content depicts parts and/or procedures applicable to the particular product at its time of manufacture. It does not include dealer modifications, whether authorized or not by BRP-Rotax, after manufacturing the product.

**Locking devices** Locking devices (e.g. locking tab, self-locking fasteners, etc.) must be installed or replaced with new ones, where specified. If the efficiency of a locking device is impaired, it must be replaced.

**Torque wrench tightening** Torque wrench tightening specifications must be strictly adhered to.

## NOTE

*If not specified otherwise, the threads are not lubricated when fastened.*

## INSTRUCTION

**General note** Engines require instructions regarding their application, use, operation, maintenance and repair. Technical documentation and directions are useful and necessary complementary elements for personal instructions, but can by no means substitute theoretical and practical instructions. These instructions should cover explanation of the technical context, advice for operation, maintenance, use and operational safety of the engine.

**Safety notice** In this technical Manual passages concerning safety are especially marked. Pass on safety warnings to other users!

**Modifications** Non-approved modifications to the engine and associated components likewise releases BRP-Rotax from its warranty obligations.

**Accessories** This engine must only be operated with accessories supplied, recommended and released by BRP-Rotax. Modifications are only allowed after the exceptional advice or approval by the engine manufacturer.

## Spare parts

### ATTENTION

Spare parts must comply with the requirements defined by the engine manufacturer. This is only warranted by use of GENUINE ROTAX® spare parts and/or accessories (see IPC) or suitable equivalent in the manufacturer's opinion. Otherwise, any limited warranty by BRP-Rotax is null and void (see latest Warranty Conditions). Spare parts are available at the authorized ROTAX® Distribution- and Service Center. Any warranty by BRP-Rotax becomes null and void if spare parts and or accessories other than GENUINE ROTAX® spare parts and/or accessories are used (see latest Warranty Conditions).

## Tools

### ATTENTION

Use only tools and appliances which are either cited in this Manual or in the Illustrated Parts Catalog of the relevant engine type for exceptional repair work.

# BRP-Rotax REPAIR MANUAL

**Engine** A fundamental requirement is that on removal of the engine for repair or maintenance purposes it should be secured on the Special Tools part no. 877930 (Trestle support) and part no. 676052 (Trestle adapter) available at your authorized Distributor or Service center for ROTAX® Kart Engines.

## TECHNICAL DOCUMENTATION

**General note** The information contained is based on data and experience that are considered applicable for skilled mechanics under normal conditions.  
Due to the fast technical progress and fulfillment of particular specifications of the customers it may occur that existing laws, safety prescriptions, constructional and operational regulations cannot be transferred completely to the object bought, in particular for special constructions, or may not be sufficient.

**Status** The current edition of the Manual is shown at the bottom of the pages or on the front cover.

**Reference** Any reference to a document refers to the latest edition issued by BRP-Rotax, if not stated otherwise.

**Illustrations** The illustrations in this Manual are sketches and show a typical arrangement. They may not represent in full detail or the exact shape of the parts which have the same or similar function. Therefore deduction of dimensions or other details from illustrations is not permitted as the scale may not be 1:1.

### NOTE

*The Illustrations and Documents in this Manual are stored in a database and are provided with a consecutive number.*

*This number (e.g. KA\_125MAX\_001) is of no significance for the content.*

## USE FOR INTENDED PURPOSE

### Safety note

**⚠ WARNING**

**Non-compliance can result in serious injuries or death!**

**Use** The ROTAX Engine Type 125 MAX has been designed and developed exclusively for use in a Kart. Any other use renders the BRP-Rotax factory limited warranty null and void.

**Maintenance and repair conditions** Use for intended purpose also includes observation of the operational, maintenance and repair conditions prescribed by the manufacturer. This is a crucial factor concerning the reliability of the engine and can increase the durability of the engine.

**BRP-Rotax**  
REPAIR MANUAL

**TECHNICAL DATA**

Engine Type	125 MAX evo / 125 Junior MAX evo / 125 Mini MAX evo / 125 Micro MAX evo
Bore/stroke	54.00 mm / 54.5 mm
Displacement	125.0 ccm
Nominal power (max.) 125 MAX evo 125 Junior MAX evo 125 Mini MAX evo 125 Micro MAX evo	22 kW at 11500 rpm 17 kW at 8500 rpm 11 kW at 8500 rpm 6 kW at 7500 rpm
Torque (max.) 125 MAX evo 125 Junior MAX evo 125 Mini MAX evo 125 Micro MAX evo	21 Nm at 9000 rpm 19 Nm at 8500 rpm 13 Nm at 8000 rpm 9 Nm at 7500 rpm
Idle speed	between 1500 and 2000 rpm
Highest permissible speed 125 MAX evo 125 Junior MAX evo 125 Mini MAX evo 125 Micro MAX evo	13500 rpm (at operation on the track, under load) 12200 rpm (at operation on the track, under load) 11500 rpm (at operation on the track, under load) 10500 rpm (at operation on the track, under load)
Ignition unit	Contactless, (variable) digital coil ignition
Spark plug	NGK GR8DI-8 or NGK GR9DI-8
Electrode gap	<1 mm <1.20 mm for 125 Micro, 125 Mini MAX evo
Fuel	Super, unleaded fuel
RON (min.)	Min. 95 Octane
Cooling	Liquid cooling: Cooling circuit with integrated coolant pump
Flow rate of the coolant pump	approx. 22 liters at 11000 rpm
Coolant mixture	100 % Water (distilled). Drain water after operation in cold condition to prevent freezing.
Coolant capacity	0.6 liter
Engine lubrication	Oil-in-gasoline lubrication, synthetic 2 Stroke oil (ROTAX XPS KART-TEC Oil part no. 29460 and ROTAX SYNMAX Oil recommended).
Mixture ratio	1:50 (2 % oil)

**BRP-Rotax**  
REPAIR MANUAL

Engine Type	125 MAX evo / 125 Junior MAX evo / 125 Mini MAX evo / 125 Micro MAX evo
Lubrication of the differential drive	SAE Engine oil 15W-40
Engine oil capacity	50 ml (for plastic balance gears) 100 ml (for steel balance gears)
Engagement speed	approx. 4000 rpm
Power transmission from centrifugal clutch to the rear axle of the kart	roller chain
Chain dimension	7.75 x 4.6 x 4.5
Number of teeth of the drive sprocket	11, 12, 13, 14, 15, 16 teeth
Weight /dry	approx 12 kg without intake silencer, carburetor, fuel pump, radiator, exhaust and battery

**BRP-Rotax**  
**REPAIR MANUAL**

**Chapter: Chapter 2**  
**MAINTENANCE**

**TOPICS IN THIS CHAPTER**

<b>General note</b> .....	<b>2</b>
<b>Authorized personnel</b> .....	<b>3</b>
<b>Process advice</b> .....	<b>4</b>
<b>Consumable materials</b> .....	<b>6</b>
<b>Special tools</b> .....	<b>8</b>
<b>Inspection and servicing intervals of the engine components</b> .....	<b>10</b>

**Contents**            The information given in the Repair Manual is based on data and experience which are considered to be applicable for a skilled mechanic under normal working conditions.

**Table of contents**    In this chapter the repair of engine ROTAX® 125 MAX evo (incl. Junior-, Mini-, Micro MAX evo) is described. Some overlapping maintenance instructions are treated as generally valid information at the beginning of this section.

**BRP-Rotax**  
**REPAIR MANUAL**

**GENERAL NOTE**

**Safety notice**

**⚠ WARNING**

**Non-compliance can result in serious injuries or death!**

Besides our instructions in the documentation supplied, also respect the generally valid safety and accident preventive directives and legal regulations.

<b>Procedures and limits</b>	The procedures and limits in this Manual constitute the manufacturers official recommendation for engine maintenance and operation
<b>Instruction</b>	The guidelines given in the Repair Manual are useful and necessary supplements to training. They, however, cannot substitute competent theoretical and practical personal instruction.
<b>Modifications</b>	Non-authorized modifications as well as the use of components and auxiliary components not corresponding to the installation instructions exclude any liability of the engine manufacturer
<b>Parts and accessories</b>	We particularly emphasize that parts and accessories not supplied as genuine BRP-Rotax parts are not verified for suitability by BRP-Rotax and thus are not authorized for use. Installation and/or use of such products may possibly change or negatively influence the constructive characteristics of the engine. For damages resulting from use of non-genuine parts and accessories manufacturer refuses any liability
<b>Special tools</b>	Maintenance of engines and systems requires special knowledge and special tools. Use only the special tools recommended by BRP-Rotax when disassembling and assembling the engine.

**BRP-Rotax**  
**REPAIR MANUAL**

**AUTHORIZED PERSONNEL**

**General note**

It is a requirement that all organizations or individuals have the required special tooling available and the necessary, training or experience to perform all tasks outlined.

**Type-specific training**

Any task outlined herein may be performed if the organization or individual has met the following conditions:

<b>Requisite knowledge</b>
<ul style="list-style-type: none"><li>• Experience in performing the task <b>and</b> knowledge of ROTAX® Installation/Operators Manual and Repair Manual</li></ul>
<b>Including:</b>
<ul style="list-style-type: none"><li>• Suitable work environment to prevent contamination or damage to engine parts or modules.</li><li>• Appropriate tools and fixtures as outlined in the ROTAX® Repair Manual.</li><li>• Reasonable maintenance practices are utilized.</li></ul>

**Information**

Maintenance organizations and individuals are encouraged to contact BRP-Rotax through its worldwide distribution network for information and guidance on any of the tasks outlined herein.

**BRP-Rotax**  
**REPAIR MANUAL**

**PROCESS ADVICE**

**Safety note**

**⚠ WARNING**

**Non-compliance can result in serious injuries or death!**  
When carrying out maintenance and service work, respect without fail the safety regulations.

**Ignition “OFF”**

**⚠ WARNING**

**Non-compliance can result in serious injuries or death!**  
This precautionary measure serves to avoid any injuries in case of an unintentional start of the engine. Principally ensure the following at each maintenance event: 1.) Ignition “OFF” and system grounded, 2) Disconnect battery and secure engine against unintentional operation.

**Handling of fluids**

**⚠ WARNING**

**Non-compliance can result in serious injuries or death!**  
Non-compliance with this instruction may cause severe burns or scalding! Hot engine parts! Always allow the engine to cool down to ambient temperature before starting work.

At maintenance of cooling-, lubricating and fuel system take care without that no contamination, metal chips, foreign material and/or dirt enters the system.

**Disassembly**

At disassembly of the engine, mark the components as necessary to avoid any mix-up. Take care of these marks, do not ruin them.

**Tool**

**ATTENTION**

In order to avoid mechanical damages, never loosen or tighten screws and nuts with pliers but only with the specified tools.

**Safety wiring**

**ATTENTION**

If during disassembling/reassembling the removal of a safety item (e.g. safety wiring, self-locking fastener, etc.) should be necessary, it must be always replaced by a new one.

# BRP-Rotax REPAIR MANUAL

## Cleaning of parts

### ATTENTION

All metal and synthetic parts are generally washed with suitable cleaning agents. Before using new and unknown cleaning agents check the compatibility of materials.

## Removed parts

Before re-using disassembled parts, clean, check and refit them as per instructions. Use clean screws and nuts only and inspect face of nuts and thread for damage. Check the contact faces and threads for damages. In case of doubt, use new screws and nuts

## Measurements

When making low tolerance measurements ( $s < 0.1$  mm) and in measuring bearing and housing components, the temperature of the components and their surroundings must be in the range 20 °C - 25 °C (68 °F – 77 °F). Only used certified measuring tools!

## Nuts

Once loosened, **always** replace self-securing nuts!

## Sealing rings, O-rings

At reassembly of the engine, replace all sealing rings, gaskets, securing elements, O-rings and oil seals.

## Re-assembly

Before re-assembly check components whether parts are missing. Only use adhesives, lubricants, cleaning agents and solvents indicated in the maintenance instructions. If not respected, damage may be the consequence and no warranty claim.

**BRP-Rotax**  
**REPAIR MANUAL**

**CONSUMABLE MATERIALS**

**General note**

**ATTENTION**

Use only the specified or **technically equivalent** materials from BRP-Rotax for all maintenance work. When handling chemicals, comply with all the customary regulations and specifications of the producer, including the expiry date and instruction.

**NOTE**

*If necessary contact the manufacturer concerning the comparability of the consumable materials. In some cases information can be obtained from the local authorized distributors and service partners for ROTAX engines.*

**NOTE**

*Respect the manufacturers instruction concerning the curing time and the expire date of the particular surface sealing compound.*

The materials specified have been tested for a long time and are suitable for all operating conditions indicated by the manufacturer.

No.	Part no.	Description, Application	Qty.
1	897651	<b>LOCTITE 243 blue</b> , medium-duty screw securing agent	10 ml (0.003 US gal.)
2	899788	<b>LOCTITE 648 geen</b> , high strength screw securing agent	5 ml (0.001 US gal.)
3	297434	<b>LOCTITE Anti-Seize 15378</b> , for the prevention of fretting corrosion	50 g (0.11 lb)
4	897161	<b>MOLYKOTE 111</b> long-term lubricant for shaft seal	100 g (0.22 lb)
5	897330	<b>Lithium-based grease or Dow Corning</b> to prevent leakage current	250 g (0.55 lb)
6	25473	<b>XPS Kart TEC DD2 Kart Gear oil</b> Lubricant	1000 ml (0.26 US gal)
7	296160	<b>Engine gasket set</b>	1
-	n.a.	<b>Cleaning agents</b>	as required

# BRP-Rotax REPAIR MANUAL

## ATTENTION

**Use only approved cleaning agents (e.g. kerosine, varsol, etc.) for cleaning all metal parts.**

Do not use lye-based cold cleaner or degreasing agents. Do not clean coolant or oil hoses with aggressive solutions. Clean off sealing compound residue with sealant remover. Soak combustion chamber, piston and cylinder head with cleaning agent and remove combustion residues with a bronze brush. Very good results have been achieved with "Clenvex 2000". It is a solvent-cold cleaner, free of halogen, on the basis of selected fuel fractions with tensides and is biologically disposable. Never use caustic or corrosive cleaning.

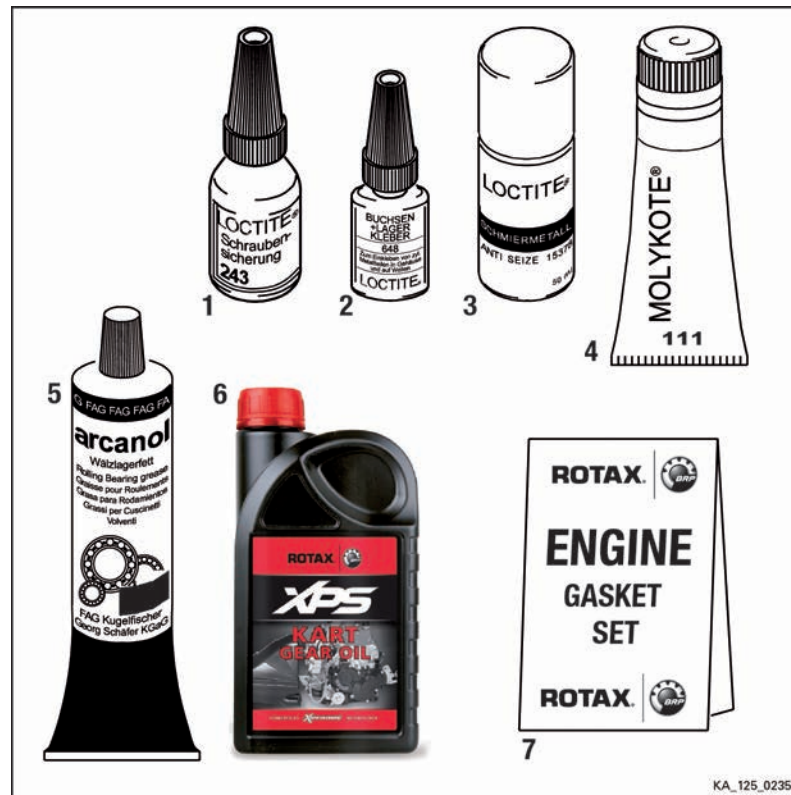

Figure 2.1

**BRP-Rotax**  
**REPAIR MANUAL**

**SPECIAL TOOLS**

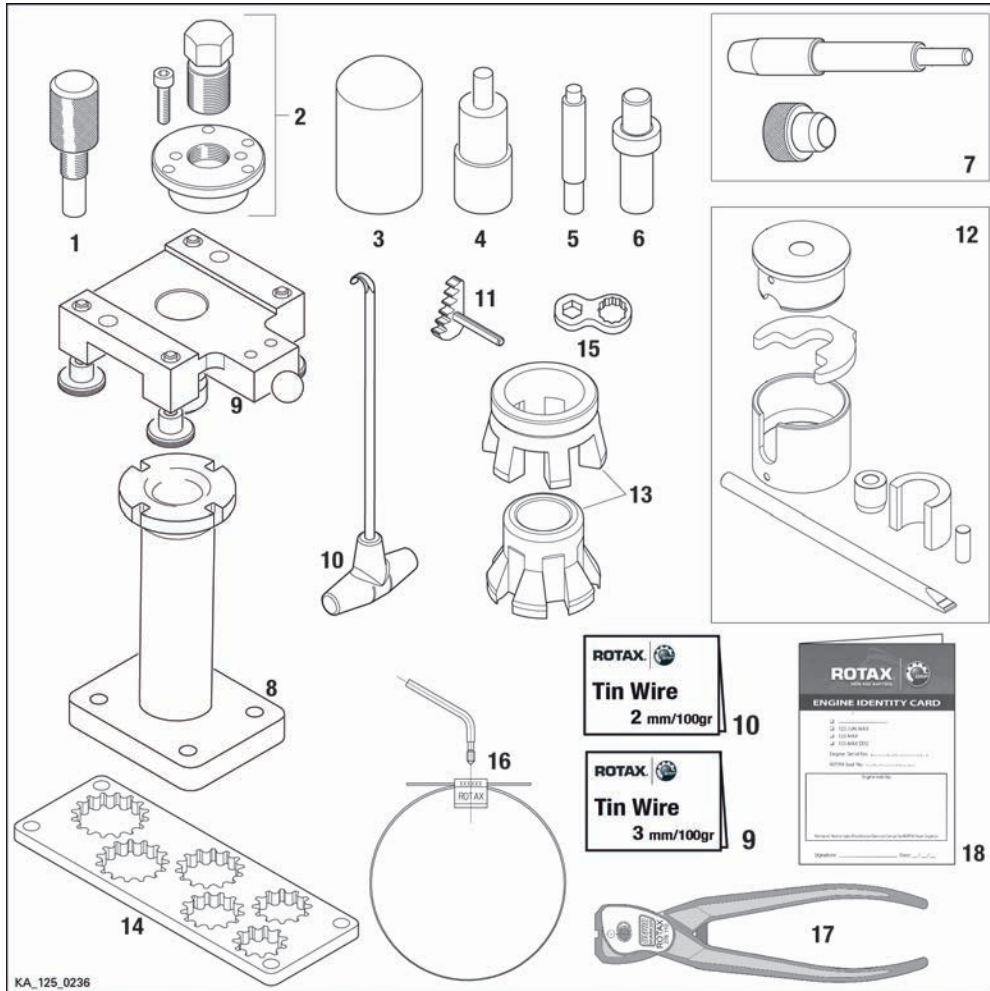

Figure 2.2

**BRP-Rotax**  
**REPAIR MANUAL**

No.	Part no.	Description
1	277381	Fixation tool for crankshaft
2	276016	Puller assy.
3	676010	Insertion sleeve
4	676021	Insertion jig
5	676030	Insertion jig
6	676040	Insertion tool
7	676035	Insertion tool
8	877930	Trestle support
9	580132	Tin wire 3 mm 100 GR
10	580130	Tin wire 2 mm 100 GR
11	676205	Fixation tool assy. MAX
12	276051	Crankshaft repair jig
13	276070	Assembly tool bellow spring exhaust v.
14	277364	Fixation, Tool for sprocket
15	676110	Wrench adapter 11/8
16	297041	ROTAX SEAL with bar code For authorised distributors only.
17	276110	ROTAX SEAL CALLIPER For authorised distributors only.
18	297240	ENGINE IDENTITY CARD

## INSPECTION AND SERVICING INTERVALS OF THE ENGINE COMPONENTS

**Safety note**

<b>⚠ WARNING</b>		
<p><b>Non-compliance can result in serious injuries or death!</b> All repair and maintenance work must only be carried out by a qualified technician.</p>		

Points of inspection	Interval Operating hours	Chapter Reference
<b>Inspection, remedial action</b>	<b>as indicated</b>	
<b>1) General</b>		
Inspect spark plug, replace if necessary	Inspect before every operation of vehicle	
Replace spark plug.	Every 25 hours of operation	
<b>2) Cooling system</b>		
Check coolant level.	Inspect before every operation of vehicle	
Inspect water pump for sealing, in the event of egress of oil or coolant from the overflow orifice, have the pump repaired by an authorised service center.	Inspect before every operation of vehicle	
Inspect the cooling water connections on the cooler housing and cylinder head cover for tightness and sealing.	Inspect before every operation of vehicle	
Inspect the radiator hoses and hose clamps on the engine and radiator for tightness and sealing.	Inspect before every operation of vehicle	
<b>3) Carburetor and intake silencer</b>		
Inspect the carburetor connections to the engine and to the intake silencer for tightness.	Immediately after every collision	
Clean the filter element in the intake silencer and lubricate with air filter oil, replace damaged filter element.	Every 10 hours (depending on the conditions of use)	

**BRP-Rotax**  
**REPAIR MANUAL**

Points of inspection	Interval Operating hours	Chapter Reference
<b>Inspection, remedial action</b>	<b>as indicated</b>	
<b>4) Fuel system</b>		
Inspect fuel filter for dirt, replace if required.	Inspect before every operation of vehicle	
Inspect fuel screen from the carburetor.	Every 10 hours of operation	
<b>5) Exhaust system</b>		
Inspect exhaust system for sealing and tightness, lubricate with oil to prevent corrosion.	Inspect before every operation of vehicle	
Replace the silencer matting in the exhaust system.	Every 10 hours of operation	
<b>6) Outlet control</b>		
Clean the exhaust valve and check for free movement.	Every 10 hours of operation	
<b>7) Gearbox</b>		
Check the oil level, top up if necessary.	Every 2 hours of operation	
Renew gear oil.	Every 5 hours of operation	
<b>8) Starter drive</b>		
Inspect for wear, replace if necessary.	Every 50 hours of operation (depending on the conditions of use)	
<b>9) Clutch</b>		
Inspect clutch drum needle bearing for wear, replace if necessary.	Every 10 hours of operation	
Clean the sealing groove in the starter gear assy.	Every 10 hours of operation	
<b>10) Engine inspection</b>		
Engine inspection by authorized service center, replace defective parts.	Every 50 hours of operation	

**BRP-Rotax**  
REPAIR MANUAL

NOTES

**BRP-Rotax**  
**REPAIR MANUAL**

**Chapter: Chapter 3**  
**ENGINE**

**TOPICS IN THIS CHAPTER**

<b>System description .....</b>	<b>2</b>
<b>Preparation for removal.....</b>	<b>3</b>
Removal of the ignition system .....	3
Removal of the exhaust system .....	6
Removal of radiator with cap assy. ....	6
Removal of the fuel line.....	7
Removal of the Bowden cable .....	8
Removal of the engine from kart chassis .....	8
Positioning the engine on the trestle mounting plate .....	9

**Contents**                      This chapter describes the disassembly and assembly of the ROTAX® 125 MAX evo (incl. Junior-, Mini-, Micro MAX evo) engine.

## SYSTEM DESCRIPTION

### Overview

### Engine

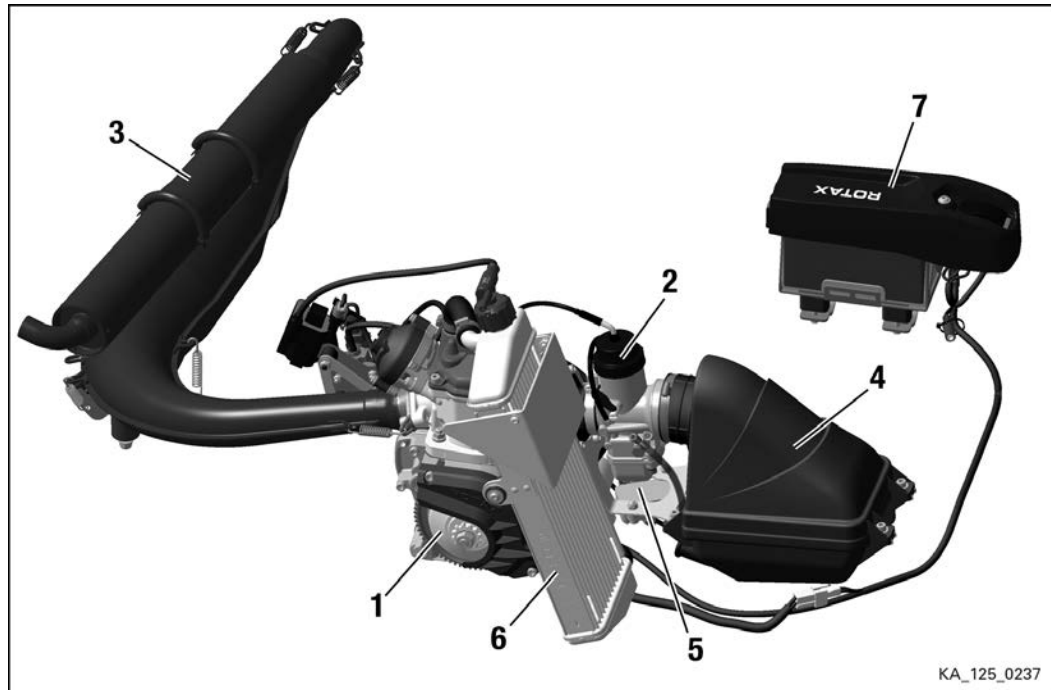

Figure 3.1: Engine components

- |   |                        |   |                 |
|---|------------------------|---|-----------------|
| 1 | Engine                 | 2 | Carburetor      |
| 3 | Exhaust system         | 4 | Intake silencer |
| 5 | Fuel pump              | 6 | Radiator        |
| 7 | Battery mounting + ECU |   |                 |

## PREPARATION FOR REMOVAL

### Safety instructions

**⚠ WARNING**

**Danger of severe burns and scalds!**

Always allow the engine to cool down to ambient temperature before starting any work.

## REMOVAL OF THE IGNITION SYSTEM

### Safety instructions

**⚠ WARNING**

**Risk of electric shock!**

Ignition "OFF" and system grounded! Disconnect negative terminal of battery.

### NOTE

*When disconnecting the battery be sure to always disconnect the negative terminal before the positive terminal. Remember that when the engine is running the ignition system has a high voltage of 35 kV; the spark plug therefore must not be removed with the engine running.*

### Instruction

Proceed as follows to disconnect battery. See [Figure: Battery](#).

1. Remove the Allen screw with rounded flange head M6x20 (3) with O-ring 5x2 (2).
2. Remove the battery cover (1).
3. Disconnect the negative battery terminal (5).

## BRP-Rotax REPAIR MANUAL

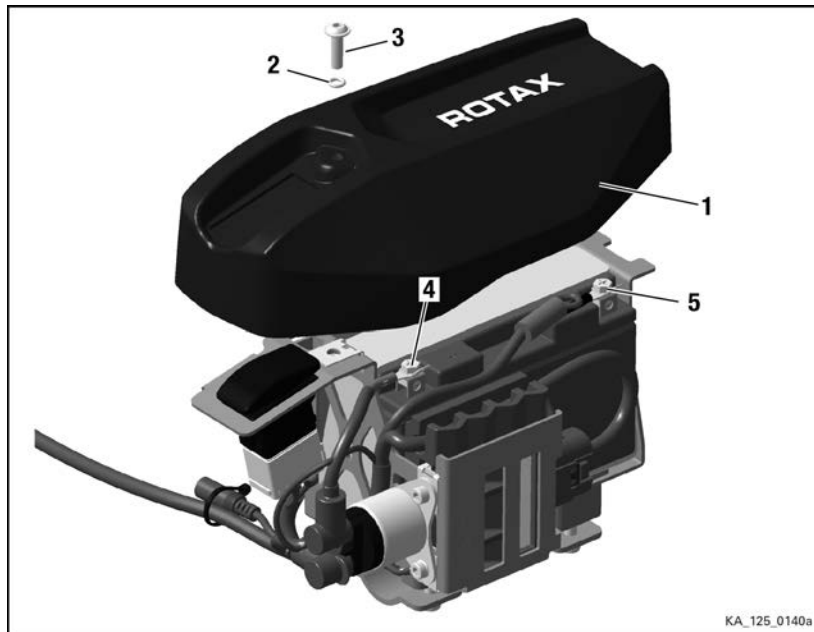

Figure 3.2: Battery

- |  |                             |
|--|-----------------------------|
| 1 Battery cover                        | 2 O-ring                    |
| 3 Allen screw with rounded flange head | 4 Positive battery terminal |
| 5 Negative battery terminal            |                             |

**Instruction** See [Figure: Ignition system](#).

4. Pull the spark plug connector (1) off the spark plug. Minimum removal force 30 N.
5. Remove the cable tie (11).
6. Disconnect the plug connections (6) on the ignition coil (2).
7. Disconnect the plug connection (7) on the solenoid valve (5).
8. Disconnect the connector (9) for the pick up sensor (3)
9. Disconnect the connector (10) for the starter (4).

# BRP-Rotax REPAIR MANUAL

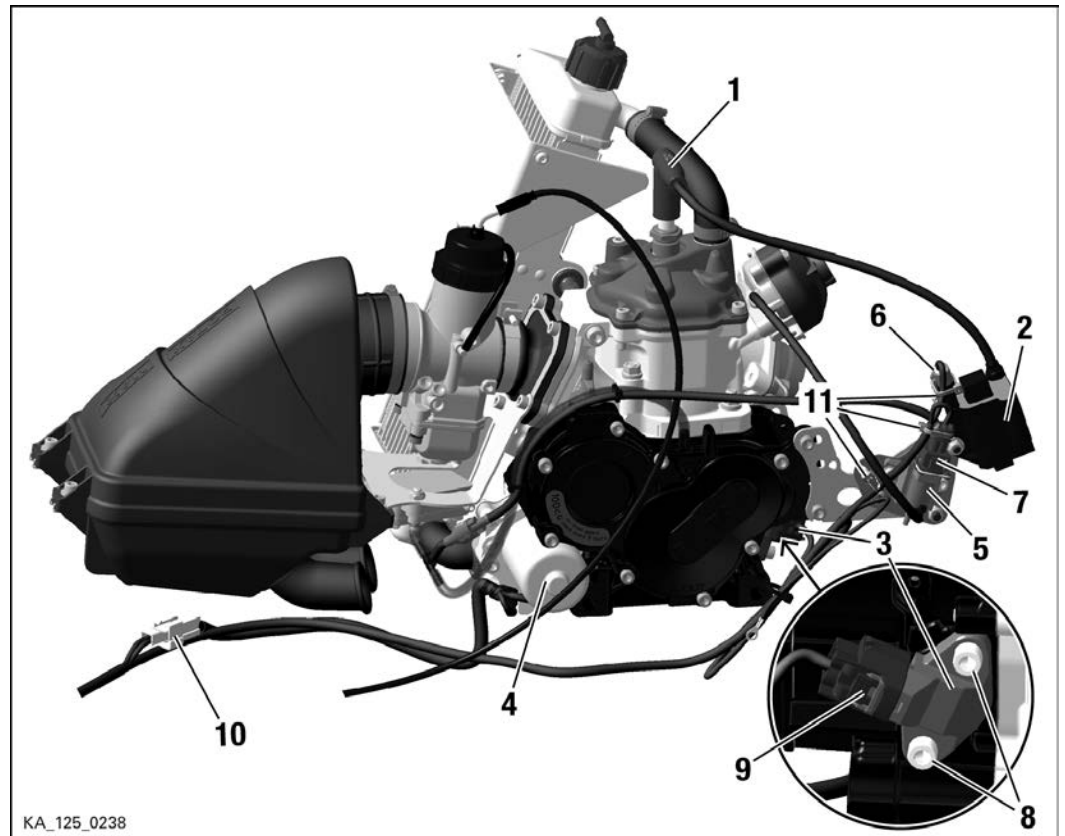

Figure 3.3: Ignition system

- |                                       |                           |
|---------------------------------------|---------------------------|
| 1 Spark plug connector                | 2 Ignition coil           |
| 3 Crankshaft positioning sensor (CPS) | 4 Electric starter        |
| 5 Solenoid valve                      | 6 Connector ignition coil |
| 7 Solenoid connector                  | 8 Allen screw M6x25       |
| 9 CPS connector                       | 10 Starter connector      |
| 11 Cable tie                          |                           |

**BRP-Rotax**  
**REPAIR MANUAL**

**REMOVAL OF THE EXHAUST SYSTEM**

**General** Proceeds follows to dismantle the exhaust system:

Step	Procedure
1	Removal of the exhaust system. See Chapter 9.

**REMOVAL OF RADIATOR WITH CAP ASSY.**

**General** Proceeds follows to dismantle the radiator with cap assy.:

Step	Procedure
1	Removal of radiator with cap assy. See Chapter 8.

# BRP-Rotax REPAIR MANUAL

## REMOVAL OF THE FUEL LINE

### Safety instructions

#### **⚠ WARNING**

#### **Danger of explosion and ignition!**

Overflowing and spoilt gasoline must be absorbed immediately with a binding agent and correctly disposed. Do not work with open flames and sources of ignition. Fuel must not come into contact with hot parts such as engine or exhaust since this may cause a fire!.

**Instruction** Proceed as follows to remove the fuel line:

1. Pull off fuel line (2) from the fuel pump (1).

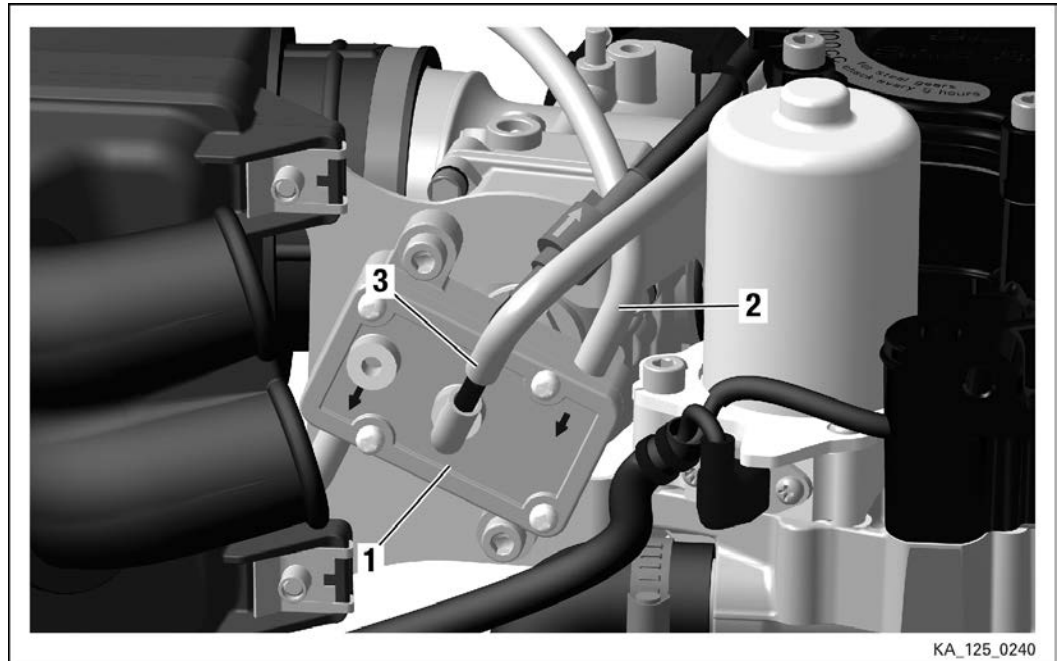

Figure 3.4: Fuel components

- 1 Fuel pump
- 3 Impulse hose

- 2 Fuel line

# BRP-Rotax REPAIR MANUAL

## REMOVAL OF THE BOWDEN CABLE

**Instruction** Proceed as follows to remove the Bowden cable:

1. Remove the carburetor cover (1).
2. Release the nipple screw from the slide.
3. Disconnect the Bowden cable (2) from the nipple screw (3).

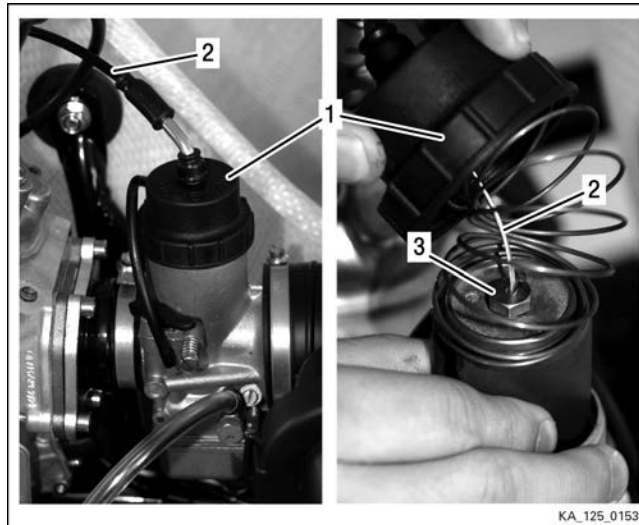

Figure 3.5: Bowden cable

1 Carburetor cover

2 Bowden cable

3 Nipple screw

---

## REMOVAL OF THE ENGINE FROM KART CHASSIS

**General** Loosen the engine from chassis following the chassis manufacturer's instruction. Remove both screws (engine clamps) and disconnect all cables.

### NOTE

*The engine **must not** be removed from the chassis to repair the following parts:*

- Centrifugal clutch
- Cylinder with combustion chamber insert and cylinder head cover
- Exhaust valve
- Reed valve
- Piston
- Starter
- Oil Service

# BRP-Rotax REPAIR MANUAL

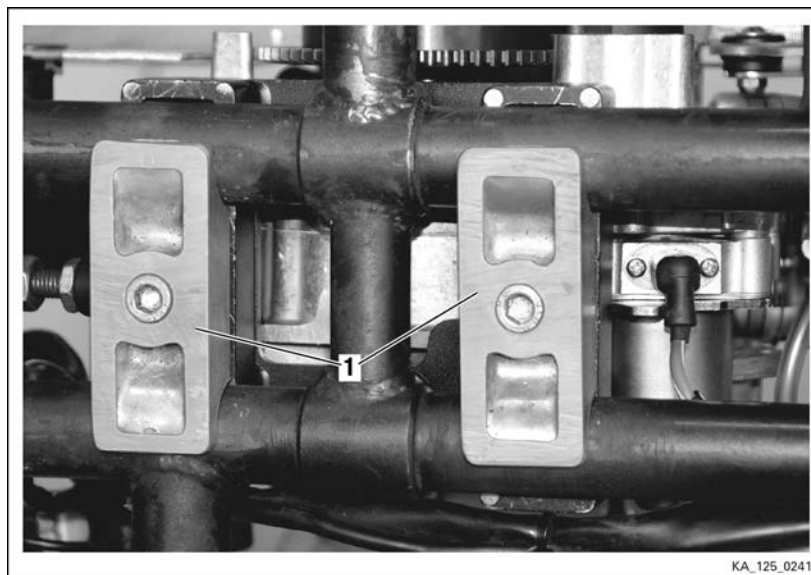

Figure 3.6: Engine clamp (Illustration similar)

1 Engine clamp

## POSITIONING THE ENGINE ON THE TRESTLE MOUNTING PLATE

### General

#### ATTENTION

Do not use flammable liquids and aggressive cleaning agents to clean the engine.

#### ENVIRONMENTAL NOTE

**Generally comply with standard rules for handling of chemicals. Dispose of chemicals as per local environmental regulations.**  
Cleaning the engine removes fuel and oil residues and other environmentally damaging substances. The waste liquid must be caught and disposed in an environmentally compatible method.

### Special tools

The following special tools and equipment are required:

Part no.	Description	Field of application
877390	Trestle mounting plate (trestle support)	Engine
676052	Fixing plate for engine	Engine

### Instructions

Proceed as follows to position the engine on the trestle mounting plate:

## **BRP-Rotax**

### **REPAIR MANUAL**

1. Engine cleaning.
2. Unscrew the base plate from the engine, position the engine on the trestle mounting plate, and fix it securely with the 4 fixing screws.

**BRP-Rotax**  
**REPAIR MANUAL**

**Chapter: Chapter 4**  
**CYLINDER COMPONENTS**

**TOPICS IN THIS CHAPTER**

<b>System description .....</b>	<b>2</b>
<b>Cylinder removal .....</b>	<b>3</b>
Removal of the spark plug .....	4
Removal of the cylinder head cover .....	4
Removal of the thermostat .....	5
Removal of the combustion chamber insert .....	6
Removal of the exhaust socket .....	7
Removal of the intake socket and reed valve .....	8
Removal of the exhaust valve (125 MAX only) .....	8
Removal of the piston .....	10
<b>Cylinder components inspection.....</b>	<b>11</b>
Inspection of cylinder components .....	11
Inspection of piston and piston ring .....	12
Inspection of the Piston diameter .....	13
Inspection of the Piston and cylinder sizing.....	14
Inspection of the Piston pin, circlip .....	15
Inspection of the spark plug.....	15
Inspection of the cylinder head cover .....	17
Inspection of the combustion chamber insert .....	17
Inspection of the exhaust socket.....	18
Inspection of the carburetor flange and reed valve .....	19
Inspection of the exhaust valve (125 MAX only) .....	20
<b>Cylinder components installation.....</b>	<b>21</b>
Installation of exhaust valve (125 MAX only).....	21
Installation of exhaust valve, gasket, valve rod housing .....	22
Installation of the exhaust valve piston .....	22
Installation of piston .....	24
Installation of the cylinder.....	25
Installation of the exhaust socket .....	26
Installation of the carburetor flange and reed valve.....	27
Installation of combustion chamber insert.....	29
Installation of cylinder head cover .....	29
Inspection and adjustment of squish gap .....	31
Installation of spark plug .....	33

**Contents**

This chapter describes the disassembly and assembly of the cylinder components of the ROTAX® 125 MAX evo (incl. Junior-, Mini-, Micro MAX evo) engine. The description is divided into sections.

**BRP-Rotax**  
**REPAIR MANUAL**

**SYSTEM DESCRIPTION**

**Overview**

Position on the engine

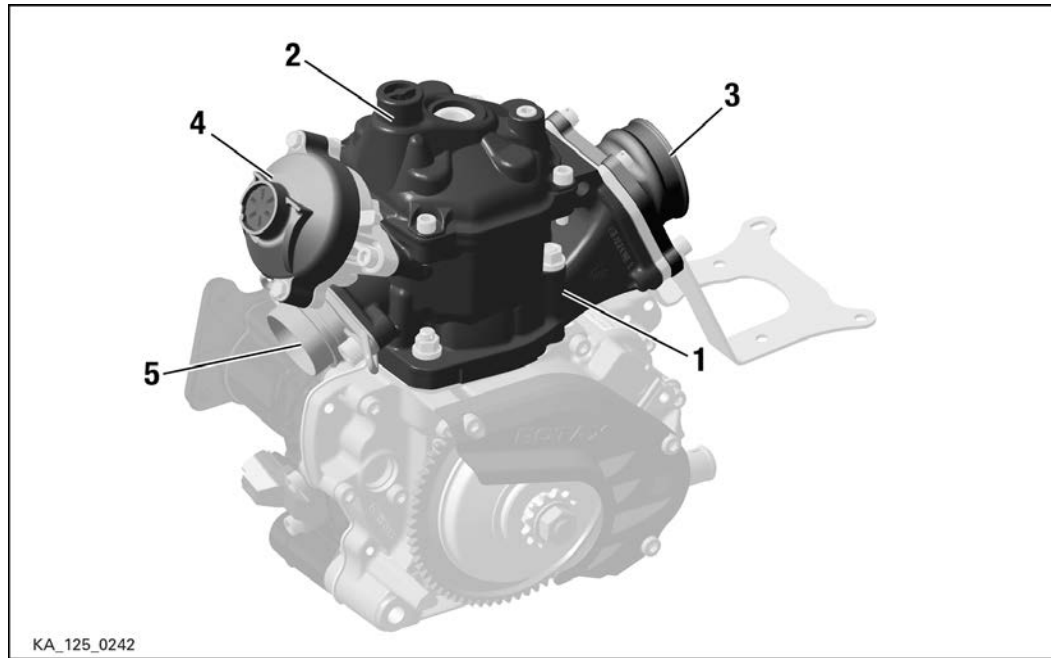

Figure 4.1: MAX evo engine shown in figure

- |   |                      |   |                     |
|---|----------------------|---|---------------------|
| 1 | Cylinder             | 2 | Cylinder head cover |
| 3 | Intake socket        | 4 | E-Rave cover        |
| 5 | Exhaust socket assy. |   |                     |

## CYLINDER REMOVAL

### General

**⚠ WARNING**

**Danger of severe burns and scalds! Always allow the engine to cool down to ambient temperature before starting any work.**

### NOTE

*If only the components in the crankcase are to be replaced or inspected, then the cylinder can be removed completely together with the following parts:*

- *Cylinder head cover*
- *Intake socket*
- *E-Rave*
- *Exhaust socket assy.*
- *Spark plug*

*The exhaust socket, carburetor flange and exhaust valve remain installed.*

### Preparation

The following preparation is required before removal:

- Removal of the radiator and radiator hoses. See also Chapter 3.
- Removal of the carburetor and intake silencer. See also Chapter 6.
- Removal of the exhaust system. See also Chapter 8.

### Instructions

**ATTENTION**

Drain the coolant from the cylinder and invert the engine to prevent entry of water into the crankcase.

**ATTENTION**

Do not damage the piston, piston ring and wall when dismantling these components.

### Special tools



The following special tools and equipment are required:

Part no.	Description	Field of application
676110	Socket set	Cylinder

# BRP-Rotax REPAIR MANUAL

## Instruction

See [Figure: Cylinder](#). Proceed as follows to remove the cylinder:

1. Remove the cylinder with the socket set by unscrewing the four M8 collar nuts from the crankcase.
2. Remove the cylinder  (1) from the crankcase.
3. Remove the cylinder base gasket  (2).

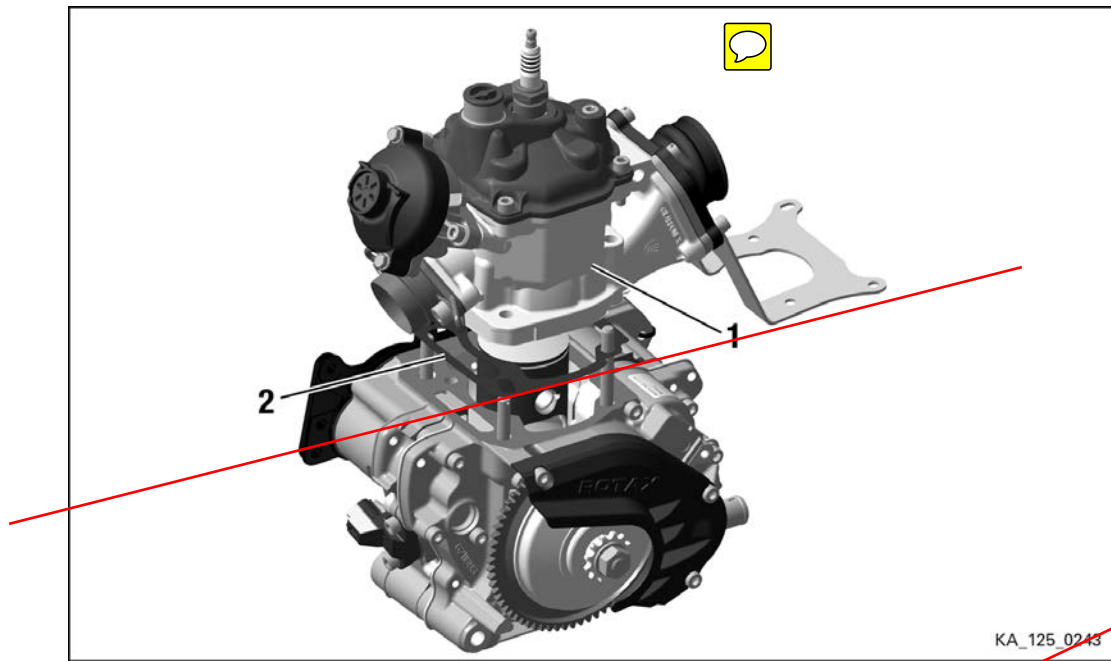

 Figure 2: Cylinder

1 Cylinder

2 Gasket

## REMOVAL OF THE SPARK PLUG

### Instruction

1. Remove the spark plug connector.
2. Remove the spark plug with the spark plug socket.

## REMOVAL OF THE CYLINDER HEAD COVER

### Instruction

See [Figure: Cylinder head cover](#).

1. Remove the cylinder head cover (1) by removing the 3 Allen screws (M6x25) (3) and 1 Allen screw M6x16 (4) from the cylinder.
2. Remove the cylinder head together with the gasket.

## BRP-Rotax REPAIR MANUAL

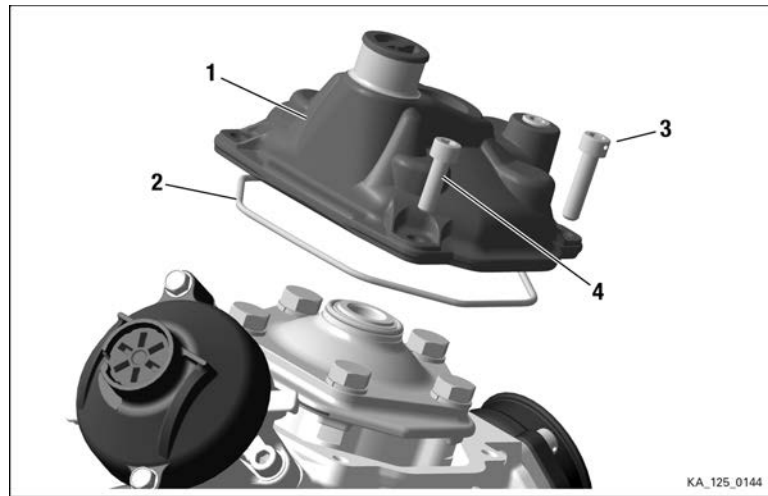

Figure 4.3: Cylinder head cover

- |   |                     |   |                   |
|---|---------------------|---|-------------------|
| 1 | Cylinder head cover | 2 | O-ring 105x2.5    |
| 3 | Allen screw M6x25   | 4 | Allen screw M6x16 |



### REMOVAL OF THE THERMOSTAT

#### Instruction

See [Figure: Thermostat](#).

1. Remove the coolant thermostat from the cylinder head cover (1) by removing the 2 TAPTITE screws M4x8 (6) on the thermostat retaining bracket (5).
2. Remove the compression spring (4).
3. Remove the thermostat (2) from the thermostat holder (3).

# BRP-Rotax REPAIR MANUAL

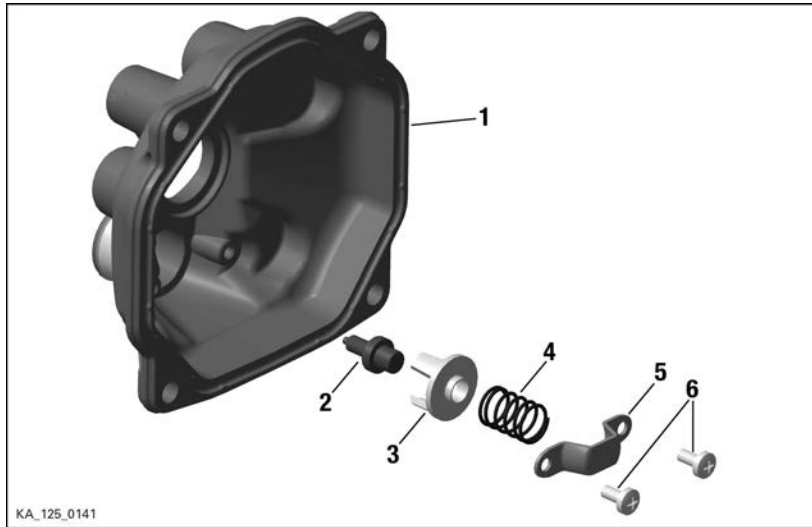

Figure 4.4: Thermostat

- |   |                              |   |                               |
|---|------------------------------|---|-------------------------------|
| 1 | Cylinder head cover          | 2 | Thermostat, 45 Degree celcius |
| 3 | Thermostat holder            | 4 | Compression spring            |
| 5 | Thermostat retaining bracket | 6 | TAPTITE screw M4x8            |

## REMOVAL OF THE COMBUSTION CHAMBER INSERT

**Instruction** See [Figure: Combustion chamber insert](#).

1. Remove the combustion chamber insert (1) by unscrewing the 5 Hex screws M8x30 (4) with the lock washer (5) crosswise.
2. Lift away the combustion chamber insert with lower (2) and upper O-rings (3).

## BRP-Rotax REPAIR MANUAL

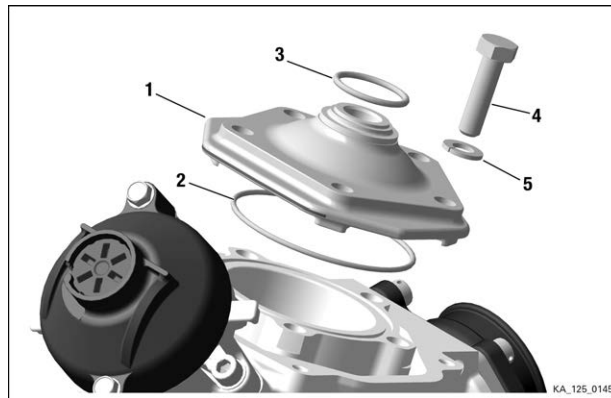

Figure 4.5: Combustion chamber insert

- |   |                           |   |                  |
|---|---------------------------|---|------------------|
| 1 | Combustion chamber insert | 2 | O-ring 64x2      |
| 3 | O-ring 23.3x2.4           | 4 | Hex. screw M8x30 |
| 5 | Lock washer A8            |   |                  |



### REMOVAL OF THE EXHAUST SOCKET

**Instruction** See [Figure: Exhaust socket](#).

1. Remove the exhaust socket (1) from the cylinder (5) by unscrewing the 2 Allen. screws (3).
2. Remove the gasket (4).

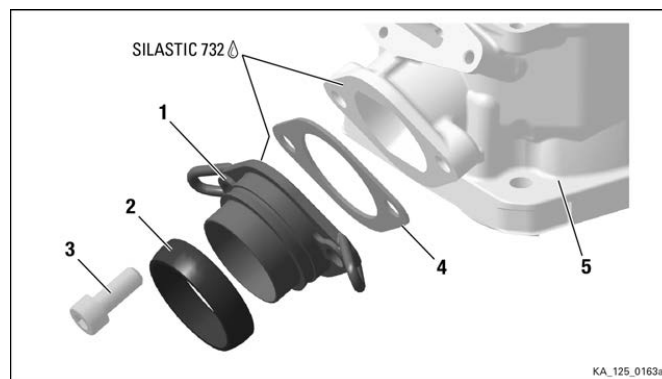

Figure 4.6: Exhaust socket

- |   |                   |   |                |
|---|-------------------|---|----------------|
| 1 | Exhaust socket    | 2 | Exhaust gasket |
| 3 | Allen screw M8x20 | 4 | Gasket         |
| 5 | Cylinder          |   |                |

## BRP-Rotax REPAIR MANUAL



### REMOVAL OF THE INTAKE SOCKET AND REED VALVE

#### Instruction

1. Remove support bracket (3) and intake socket (4) by loosening the 5 Allen screws M6x25 (1) (2).
2. Remove the reed valve (5) and gasket (6) from the cylinder.

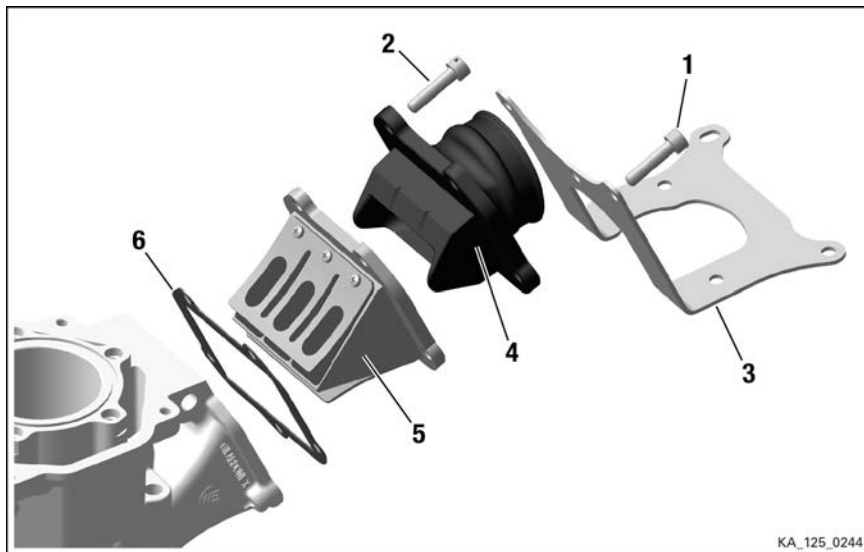

Figure 4.7: Intake socket, Reed valve

- |   |  |   |                   |
|---|--|---|-------------------|
| 1 | Allen screw M6x25 with hole for sealing the engine | 2 | Allen screw M6x25 |
| 3 | Support bracket                                    | 4 | Intake socket     |
| 5 | Reed valve assy.                                   | 6 | Gasket            |



### REMOVAL OF THE EXHAUST VALVE (125 MAX ONLY)

#### General

The engine has an electronically controlled magnet valve which is opening and closing at a certain rpm defined by the ECU. The opening rpm can be set to following:

- 7900 rpm if the additional ground cable on the battery box is disconnected.
- 7600 rpm if the additional ground cable is connected to the battery box.

The closed valve improves the performance in the low and mid range. In the upper rpm range the valve opens to reduce flow resistance of the exhaust gases. For a detailed explanation please visit our website and watch our animated video that will explain the function in detail: <https://www.rotax-kart.com/de/Community/Videos/Rotax-125-MAX-evo-Engines/124-Rotax-E-RAVE>

## BRP-Rotax REPAIR MANUAL

### Instruction

See [Figure: Exhaust valve \(RAVE\)](#)

Proceed as follows to remove the exhaust valve:

1. Release the adjustment screw (1) with the O-ring (2).
2. Remove the 2 TAPTITE screws M5x25 (3).
3. Remove the valve cover (4) and the compression spring (5).
4. Lift away the outer hose spring (6).
5. Unscrew the exhaust valve piston (7).
6. Remove the inner hose spring (9) from the bellows (8), push out the valve bellows from the valve piston.
7. Release the valve rod housing (10) from the cylinder with the 2 Allen screws M6x25 (11) with spring washers (12). Remove the gasket (13).
8. Remove the exhaust valve (14) with O-ring (16) and stud (15).

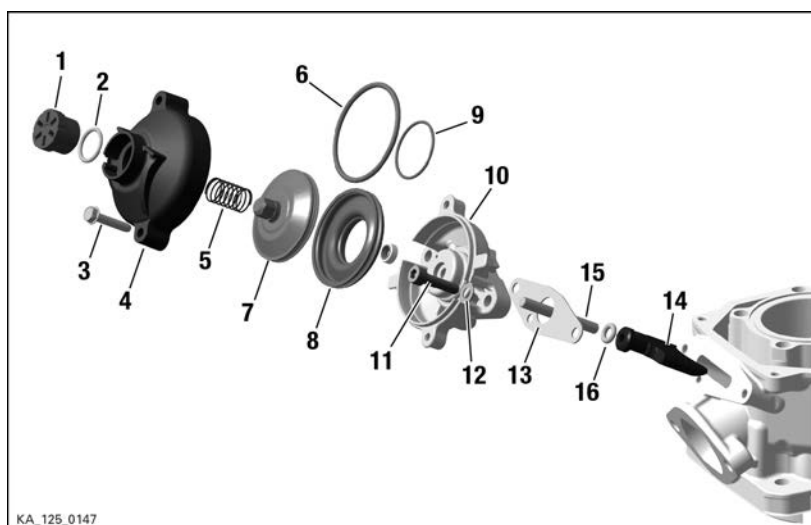

Figure 4.8: Exhaust valve (RAVE)

- |                                  |                            |
|----------------------------------|----------------------------|
| 1 Adjustment screw               | 2 O-ring 15.9–2.3          |
| 3 TAPTITE screw M5x25            | 4 Valve cover              |
| 5 Compression spring 48.5/0.8 mm | 6 Hose spring 134–3.0–0.65 |
| 7 Exhaust valve piston           | 8 Bellow                   |
| 9 Hose spring 70–1.7–0.3         | 10 Valve rod housing assy. |
| 11 Allen screw M6x25             | 12 Spring washer B6        |
| 13 Gasket                        | 14 Exhaust valve           |
| 15 Stud M6x52.5                  | 16 O-ring 6x2.5 RED        |

# BRP-Rotax REPAIR MANUAL

## REMOVAL OF THE PISTON

General

See [Figure: piston](#).

### ATTENTION

In order to protect the piston pin circlip from unintentional loss, a suitable clean cloth should be used to cover the open cylinder bore in the crankcase.

### ATTENTION

Always support the piston with the hand in order to avoid a bending moment or damage of the surface.

Special tools

The following special tools and equipment are required:

Part no.	Description	Field of application
676035	Insertion tool	Piston
976380	Circlip puller	Circlip

Instructions

Proceed as follows to remove the piston:

1. Pull out the circlip (2) with the circlip puller (1). Use safety goggles to protect your eyes!
2. Press the piston pin (4) out of the piston with the point of the special tool (3).

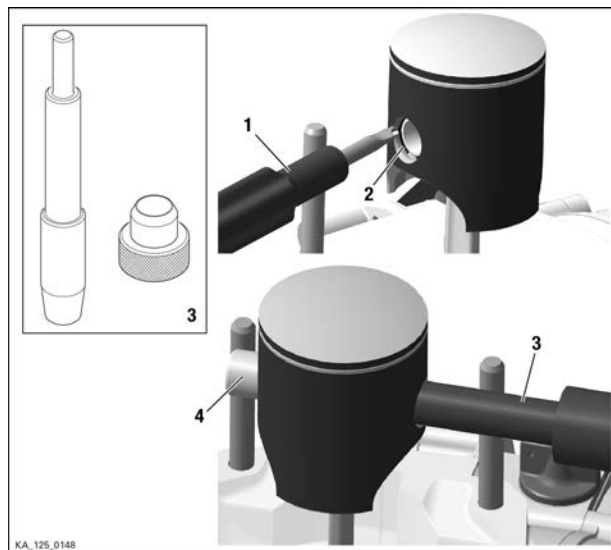

Figure 4.9: Piston

1 Circlip puller

2 Circlip

3 Special tool part no. 676035

4 Piston pin

## CYLINDER COMPONENTS INSPECTION

### General

#### ATTENTION

Components, which have reached or exceeded their wear limits, must be replaced. Components, which are found to be defective in the context of the visual inspection and might influence the engine's performance, must also be replaced.

### INSPECTION OF CYLINDER COMPONENTS

**Instructions** See [Figure: Cylinder](#).

**Preparation** The following preparation is required before removal.

1. Remove lime deposits (1) from the water cooling of the cylinder.
2. Clean combustion residues from the exhaust valve and slider duct (2).
3. Clean O-ring groove (3).
4. Inspect all threads.
5. All sealing surfaces must be clean and smooth.
6. Inspect the cylinder bore for abnormal wear.
7. Inspect the impulse bore (4).

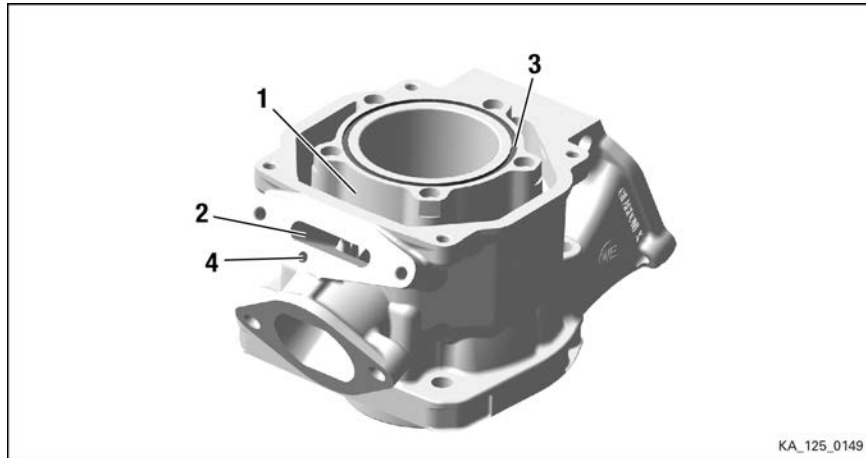

Figure 4.10: Cylinder

1 Water duct

2 Exhaust valve port

3 Groove for O-ring

4 Impulse bore

# BRP-Rotax REPAIR MANUAL

## INSPECTION OF PISTON AND PISTON RING

**Instructions** See [Figure: Piston and piston ring](#).

1. Inspect the piston for cracks and signs of piston seizure.
2. Inspect the bore of the piston pin for damage and wear.
3. Inspect the piston pin ring groove for defects.
4. Check free of movement of the piston ring in the ring groove.

### NOTE

*If carbon prevents free movement of the piston ring, the ring groove can be cleaned out with a discarded piston ring.*

5. Measure the piston ring clearance in the ring groove with a feeler gauge (1).

### NOTE

*If the piston ring clearance has reached the wear limit of 0.1 mm, the piston must be replaced.*

6. Remove the piston ring from the piston, insert it approx. 10 mm from top into the cylinder (use the piston to do so) and check ring-end gap by means of a feeler gauge.
7. Measure clearance with a feeler gauge.

### NOTE

*If the wear limit of 0.8 mm has been reached the piston ring must be replaced.*

8. Check the piston ring locking pin for wear.

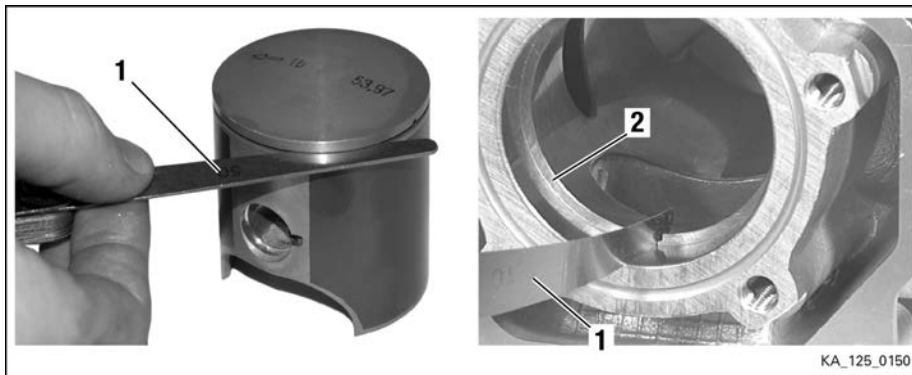

Figure 4.11: Piston and piston ring

1 Feeler gauge

2 Piston ring

# BRP-Rotax REPAIR MANUAL

## INSPECTION OF THE PISTON DIAMETER

### Instructions

1. Measure the piston diameter with a micrometer (1). Conditions of measurement: room temperature = 20 °C, measuring point 20 mm from the lower edge of the piston, perpendicular to the piston pin axis.
2. Determine the piston to cylinder clearance. The wear limit is 0.08 mm.

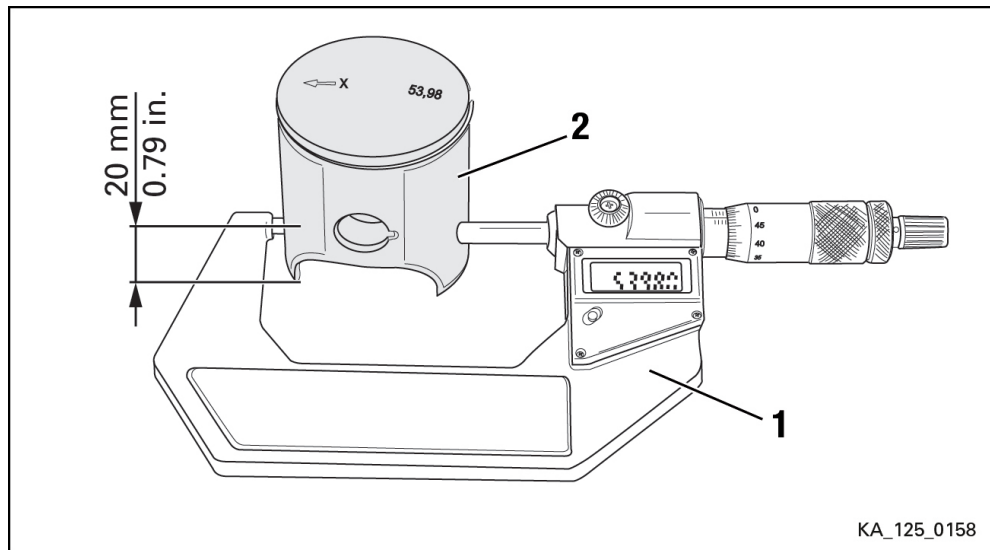

Figure 1.12: Piston diameter

1 Micrometer

# BRP-Rotax REPAIR MANUAL

## INSPECTION OF THE PISTON AND CYLINDER SIZING

### General

#### NOTE

*Every new piston has the size classification and a production letter printed on the top of the piston (piston crown).*

#### NOTE

*Every new cylinder has the size classification stamped on the upper sealing surface.*

#### Measuring the cylinder diameter:

1. Measure the cylinder diameter 10 mm below the upper edge of the cylinder. This dimension indicates the selection of the matching piston. If the dimension has reached the wear limit of 54.045 mm, the cylinder must be replaced.
2. Measure the piston diameter as described in chapter 4 "Inspection of the piston diameter" and install a piston to match the required clearance at 0.060 mm +/- 0.005 mm between piston and cylinder.

#### Cylinder classification

Cylinder labeling	Cylinder dimension
"A"	54.000 - 54.010 mm
"AB"	54.010 - 54.015 mm
"B"	54.015 - 54.025 mm

#### Piston classification "f"

Piston labeling	Tolerance field (mm)	Minimum dimension (mm)	Maximum dimension (mm)
"f" 53.95	+0.005 / -0.025 mm	53.925	53.955
"f" 53.96	+0.005 / -0.025 mm	53.935	53.965
"f" 53.97	+0.005 / -0.025 mm	53.945	53.975
"f" 53.98	+0.005 / -0.025 mm	53.955	53.985
"f" 53.99	+0.005 / -0.025 mm	53.965	53.995

# BRP-Rotax REPAIR MANUAL

Piston classification "h"

Piston labeling	Tolerance field (mm)	Minimum dimension (mm)	Maximum dimension (mm)
"h" 53.94	+0.015 / -0.015 mm	53.925	53.955
"h" 53.95	+0.015 / -0.015 mm	53.935	53.965
"h" 53.96	+0.015 / -0.015 mm	53.945	53.975
"h" 53.97	+0.015 / -0.015 mm	53.955	53.985
"h" 53.98	+0.015 / -0.015 mm	53.965	53.995

## INSPECTION OF THE PISTON PIN, CIRCLIP

**Instructions** See [Figure: Piston pin, circlip](#).

1. Inspect the piston pin (1) for wear and discoloration.
2. Check the needle cage (2) for cracks and abrasion.
3. The circlips (3) are replaced at every repair. Notice the position of the circlip.

### NOTE

*Direction of circlips is up or downside direction.*

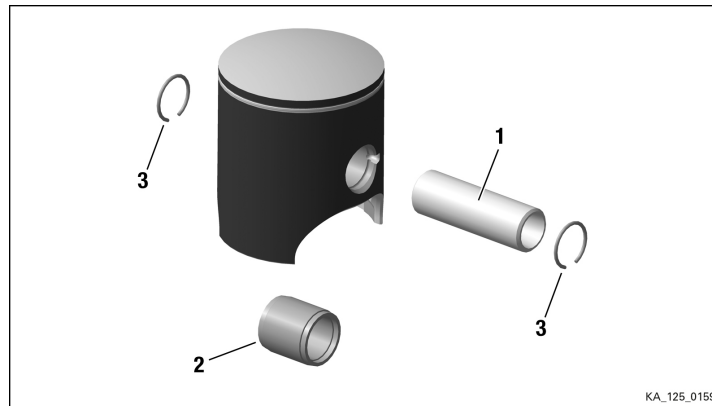

Figure 1.13: Piston pin, circlip

1 Piston pin

2 Needle cage

3 Circlip

# BRP-Rotax REPAIR MANUAL

## INSPECTION OF THE SPARK PLUG

**Instructions** See [Figure: Spark plug](#).

1. Inspect spark plug connector for cracks, burn-off, dampness and fouling.
2. Visual inspection of the spark plug for carbonization, oil fouling and discoloration of the electrode.
  - Pos. 1 = normal
  - Pos. 2 = fouled
  - Pos. 3 = insulator breakage
  - Pos. 4 = melted electrode
  - Pos. 5 = oil carbon / deposits
3. Check the electrode gap of the spark plug with a feeler gauge and adjust if required to  $s = 0.45 \text{ mm to } 0.7 \text{ mm}$ .

### ATTENTION

Pay attention to the electrode gap, mentioned in the technical regulation! Bending the electrode can cause damage or misfire.

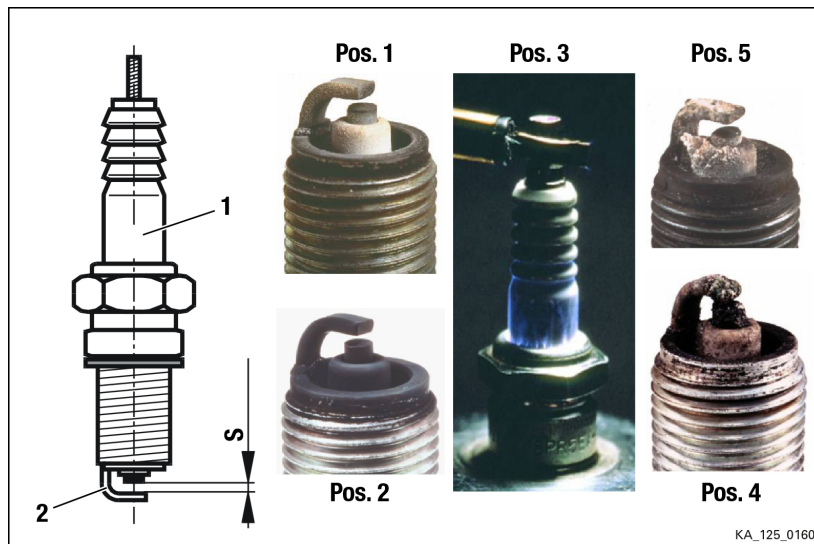

Figure 1.14: Spark plug

1 Spark plug

2 Electrode

## INSPECTION OF THE CYLINDER HEAD COVER

**Instructions** See [Figure: Cylinder head cover](#).

1. Inspect cylinder head cover for cracks (visual inspection).
2. Inspect the contact surfaces of the two O-rings (1 and 2) for good condition (max. depth of wear 0.05 mm).

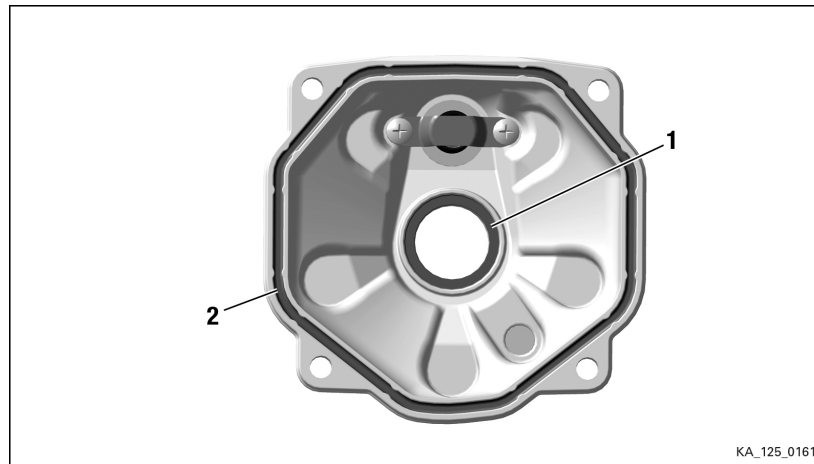

Figure 1.15: Cylinder head cover

1, 2 O-ring contact area

---

## INSPECTION OF THE COMBUSTION CHAMBER INSERT

**Instructions** See [Figure: Combustion chamber insert](#).

### NOTE

*The sealing area of the combustion chamber insert is slightly tapered from  $\varnothing$  63 mm.*

1. Clean combustion residues and lime deposits from the outer area (1) of the combustion chamber.
2. Inspect combustion chamber insert for cracks (visual inspection).
3. Make sure that spark plug thread (3) is in good condition.
4. Inspect sealing surfaces for flatness and damage.

## BRP-Rotax REPAIR MANUAL

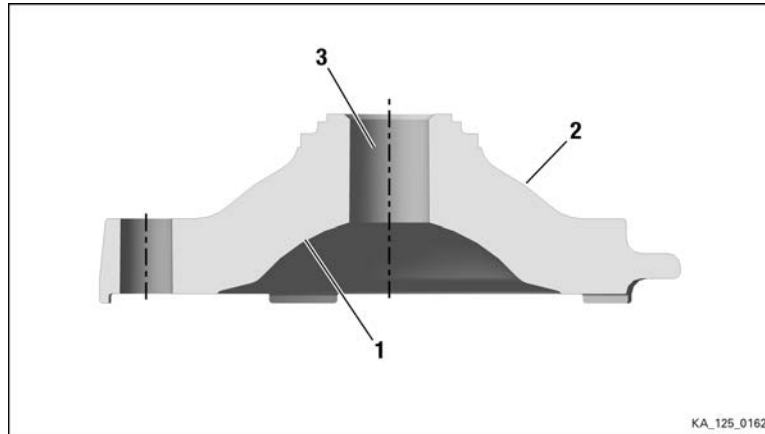

Figure 4.16: Combustion chamber insert

- |   |                    |   |              |
|---|--------------------|---|--------------|
| 1 | Combustion chamber | 2 | Outside area |
| 3 | Spark plug thread  |   |              |

### INSPECTION OF THE EXHAUST SOCKET

**Instructions** See [Figure: Exhaust socket](#).

1. Inspect the exhaust socket for damage or deformation.
2. Inspect exhaust gasket (2) for wear and replace if applicable.



Figure 4.17: Exhaust socket

- |   |                       |   |                |
|---|-----------------------|---|----------------|
| 1 | Exhaust socket (ball) | 2 | Exhaust gasket |
|---|-----------------------|---|----------------|

# BRP-Rotax REPAIR MANUAL

## INSPECTION OF THE CARBURETOR FLANGE AND REED VALVE

### General

#### ATTENTION

The reed petal should be completely on the valve guide with a little initial tension (a gap should not be visible when held against the light. If applicable adjust reed valves more precisely by releasing the tightening torque of the screws.

**Instructions** See [Figure: Carburetor port and valve guide](#).

1. Inspect rubber lining of reed valves (1) for perishing (if applicable replace complete reed valve).
2. Check the two reed petal (2) for cracks or damage.
3. Check the oval head screw M3x6 (3) for secure seating. (LOCTITE 648 Tightening torque 1.5–2 Nm (13-18 in.lb)).
4. Inspect carburetor flange (4) for cracks, porosity or swelling and replace if applicable.

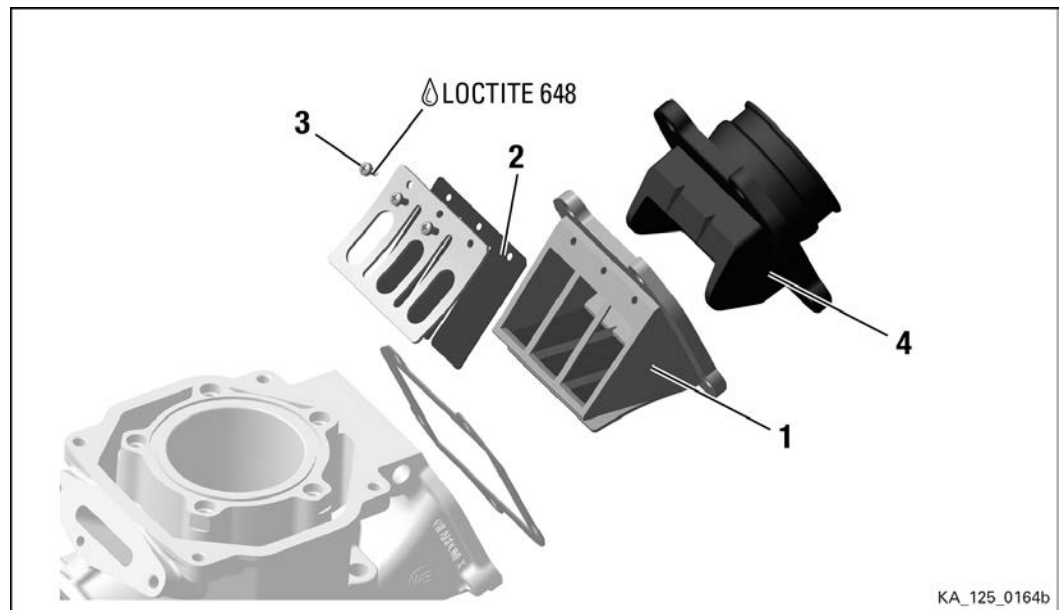

Figure 4.18: Carburetor port and valve guide

- |                        |                 |
|------------------------|-----------------|
| 1 Reed valve assy.     | 2 Reed petal    |
| 3 Oval head screw M3x6 | 4 Intake socket |

# BRP-Rotax REPAIR MANUAL

## INSPECTION OF THE EXHAUST VALVE (125 MAX ONLY)

**Instructions** See following figure.

**Preparation** The following preparation is required before removal.

1. Clean oil or oil deposits from all parts with a suitable cleaning agent.
2. Check the smooth movement of the exhaust valve (1) in the cylinder, if applicable remove carbon deposits on the outlet valve and in the cylinder.
3. Inspect condition of O-ring (2).
4. Check that the impulse bore in the valve rod housing (3) is open.
5. Inspect bellow (5) for cracks or porous areas and replace if applicable.
6. Inspect exhaust valve piston (6) for cracks or deformation by caused overheating and replace if applicable.
7. Inspect valve cover (7) for cracks or deformation caused by overheating.

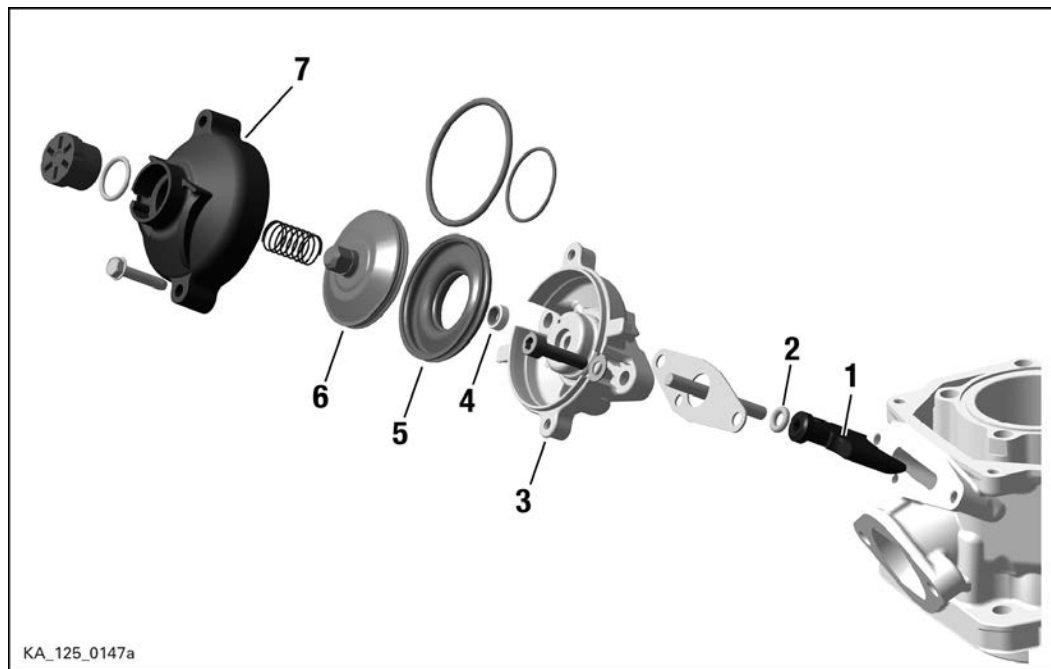

Figure 4.19: Exhaust valve

- |                     |                |
|---------------------|----------------|
| 1 Exhaust valve     | 2 O-ring RED   |
| 3 Valve rod housing | 4 Oil seal     |
| 5 Bellow            | 6 Valve piston |
| 7 Valve cover       |                |

**BRP-Rotax**  
**REPAIR MANUAL**

**CYLINDER COMPONENTS INSTALLATION**

**INSTALLATION OF EXHAUST VALVE (125 MAX ONLY)**

**NOTE**

*Make sure that the components are installed in their correct position.*

**Special tools**

The following special tools and equipment are required:

Part no.	Description	Use
899788	LOCTITE 648	Stud bolt
276070	Installation tool	Valve bellows spring

**Instruction**

See [Figure: Exhaust valve..](#)

Proceed as follows to install the exhaust valve:

**ATTENTION**

If the exhaust valve or the stud bolt is replaced, the stud bolt must be secured with LOCTITE 648 in the exhaust valve.

1. Lock exhaust valve (1) and stud M6x52.5 (2) with LOCTITE 648.
2. Wipe away the surplus LOCTITE.
3. Make sure the bolt is screwed in completely. Tightening torque 10 Nm (90 in.lb).

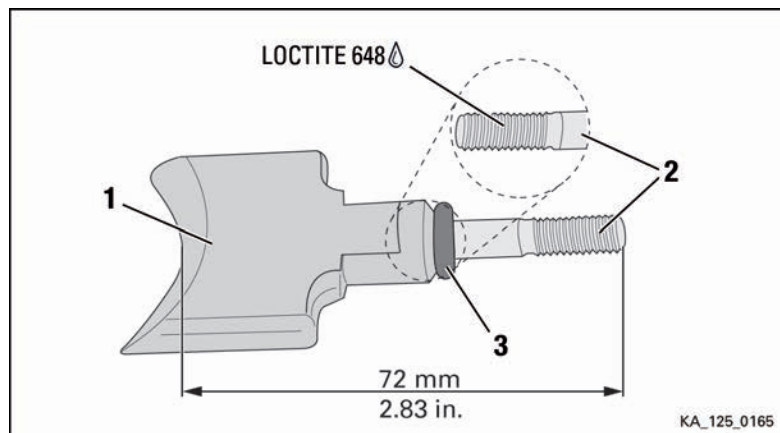

Figure 4.20: Exhaust valve

- 1 Exhaust valve
- 3 O-ring 6x2.5 RED

2 Stud M6x52.5

# BRP-Rotax REPAIR MANUAL

## INSTALLATION OF EXHAUST VALVE, GASKET, VALVE ROD HOUSING

Exhaust valve, gasket, valve rod housing See [Figure: Exhaust valve](#).

1. Insert exhaust valve into the slot in the cylinder head (1). Pay attention on the installation direction and make sure that the valve is not ranging into the exhaust port!
2. Position the gasket (4), making sure that the impulse bore on the cylinder is not covered. Note the installation direction!
3. Insert the valve rod housing (5). Coat both side of oil seal (6) with Engine oil and insert into the valve rod housing.
4. Screw in 2 Allen screws M6x25 (7) and spring washers (8) onto the cylinder (1) and tighten.
5. Check the movement of the exhaust valve.
6. Tighten Allen screws (7). Tightening torque 10 Nm (90 in.lb).

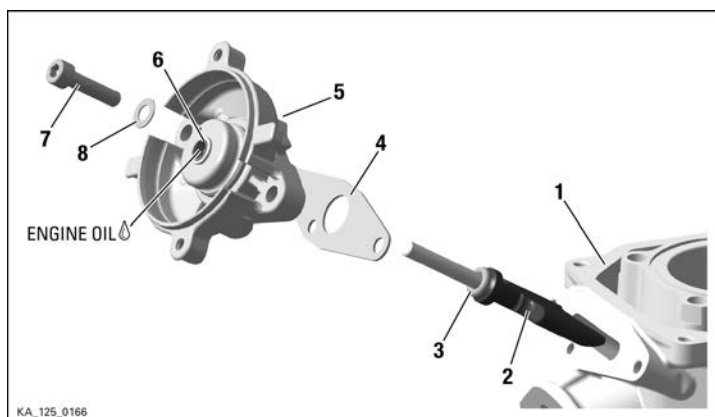

Figure 4.21: Installation direction of exhaust valve

- |   |                         |   |                     |
|---|-------------------------|---|---------------------|
| 1 | Cylinder head           | 2 | Exhaust valve       |
| 3 | O-ring 6x2.5 RED        | 4 | Gasket              |
| 5 | Valve rod housing assy. | 6 | Oil seal 6x11x3/4.5 |
| 7 | Allen screw M6x25       | 8 | Spring washers B6   |

## INSTALLATION OF THE EXHAUST VALVE PISTON

### General

In order to protect the piston pin circlip from unintentional loss in the crankcase, a suitable clean cloth should be used to cover the open cylinder bore.

### Instruction

See [Figure: Exhaust valve piston](#).

1. Degrease the valve rod housing (1), bellows (2) and exhaust valve piston (3).
2. Pull the small hose spring (4) over the bellows.

## BRP-Rotax REPAIR MANUAL

3. Fit the bellows over the valve rod housing (1). The bead of the bellows must engage in the groove in the valve rod housing.
4. Tighten the exhaust valve piston (3) into the valve rod housing (1). Tightening torque 1.2 Nm (10.6 in.lb)
5. Tension the large hose spring (5) with installation tool part no. 276070.
6. Insert compression spring (6).
7. Tighten the valve cover (7) with 2 TAPTITE screw M5x25 (8).
8. Insert the O-ring 15.9-2.3 (9) into the valve cover.
9. Turn the adjustment screw (10) into the valve cover (7).

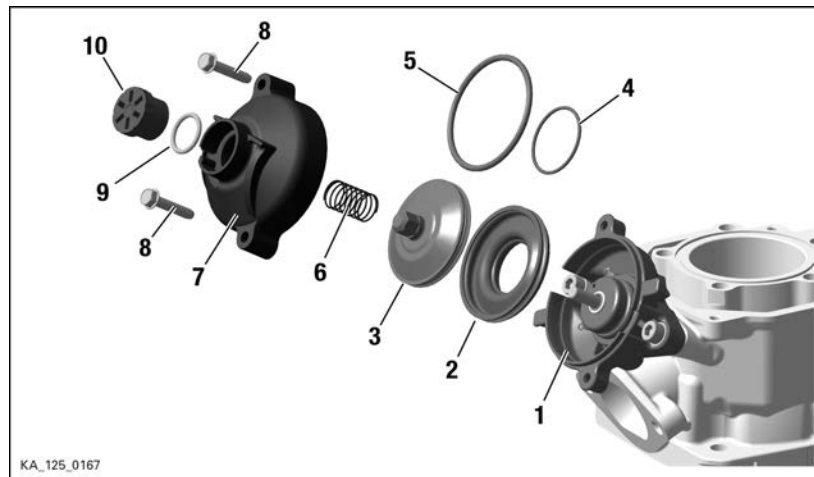

Figure 4.22: Exhaust valve piston

- |   |                          |    |                                |
|---|--------------------------|----|--------------------------------|
| 1 | Valve rod housing assy.  | 2  | Bellow                         |
| 3 | Exhaust valve piston     | 4  | Hose spring 70-1.7-0.3         |
| 5 | Hose spring 134-3.0-0.65 | 6  | Compression spring 48.5/0.8 mm |
| 7 | Valve cover              | 8  | TAPTITE screw M5x25            |
| 9 | O-ring 15.9-2.3          | 10 | Adjustment screw               |

# BRP-Rotax REPAIR MANUAL

## INSTALLATION OF PISTON

**Special tools** The following special tools and equipment are required:

Part number	Description	Field of application
676035	Installation tool	Piston
n.a.	Engine oil	Piston pin

### NOTE

*Cover your eyes with safety goggles during this work!  
Mount the piston with the locking pin of the piston ring facing the intake port.*

### NOTE

*The piston pin is fixed in the piston with two circlips (left and right).*

### ATTENTION

**Always use new circlips. Used or previously installed circlips have too little tangential tension, and they may twist and work their way out of the groove in the piston.**

### NOTE

*For easier installation we recommend installing one circlip before installing the piston.*

### Instruction

See [Figure: Piston pin](#).  
Proceed as follows to install the piston pin:

1. Coat the piston pin needle cage (2) with Engine oil.
2. Insert the piston pin needle cage (2) into the upper connecting rod eye.
3. Mount the piston (3) and piston pin (4) on the con rod.
4. Place the new circlip (1) flat on a level surface.
5. Push the mounting sleeve (5) with the circlip over it.
6. Push the circlip deeper into the mounting sleeve with the tapered side of the installation tool (6).
7. Rotate the installation tool and continue to push the mounting sleeve until the circlip locks into the mounting sleeve groove.
8. Place the installation tool with the cutout of the circlip down on the piston (3).
9. Protect the piston with your hand and press into the piston with the hook ring.

### NOTE

*The installation tool centers itself in the piston pin.*

# BRP-Rotax REPAIR MANUAL

## NOTE

*Check that the circlip is correctly seated in the piston.*

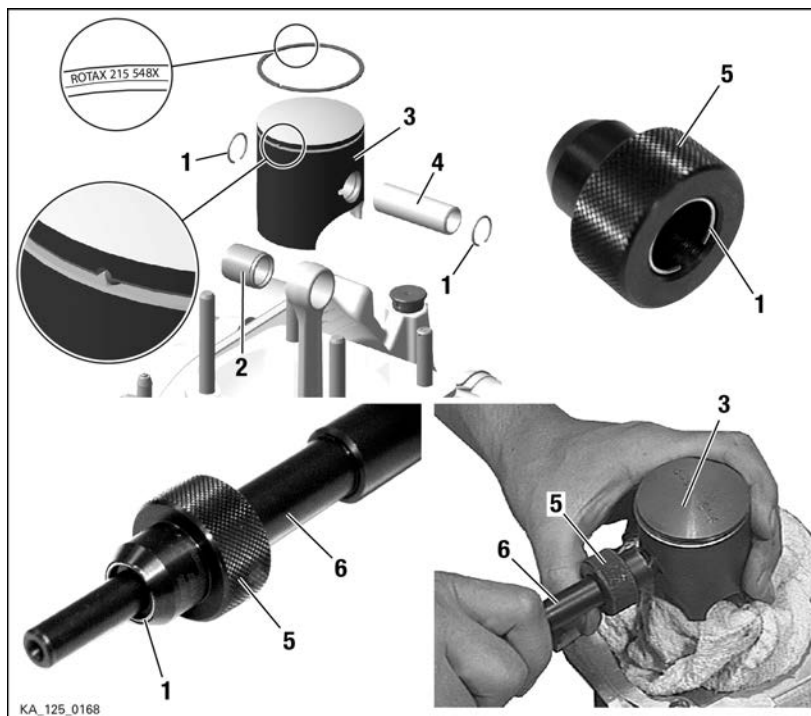

Figure 4.23: Piston pin

- |                   |                              |
|-------------------|------------------------------|
| 1 Circlip         | 2 Needle cage K 15x19x20     |
| 3 Piston          | 4 Piston pin 15x10x12.5x45.6 |
| 5 Mounting sleeve | 6 Installation tool          |

## INSTALLATION OF THE CYLINDER

### General

#### ATTENTION

**Use only the piston/cylinder pairings specified by the table in Chapter 4 Section 3.2. All other combinations may lead to engine damage.**

### Special tools

The following special tools and equipment are required:

Part no.	Description	Field of application
897651	LOCTITE 243	Stud bolts

# BRP-Rotax REPAIR MANUAL

## Instructions

Proceed as follows to install the cylinder head: See [Figure: Cylinder head](#).

1. Coat the stud bolts (1) on the longer thread end with LOCTITE 243 and screw into the crankcase. Tightening torque 5 Nm (44.25 in.lb).
2. Position new cylinder base gasket (0.2 mm) (4). Determine the correct thickness of the base gasket (see Chapter 4 Section: Squish gap measurement) to adjust the squish gap to the correct value.
3. Coat cylinder bore and piston (2) with Engine oil.
4. Press piston ring into the piston with two fingers.

### ATTENTION

**Do not damage the gasket.**

5. Position the cylinder (3) over the piston.
6. Screw cylinder crosswise to the crankcase with the four studs. Tightening torque 24 Nm (18 ft.lb).

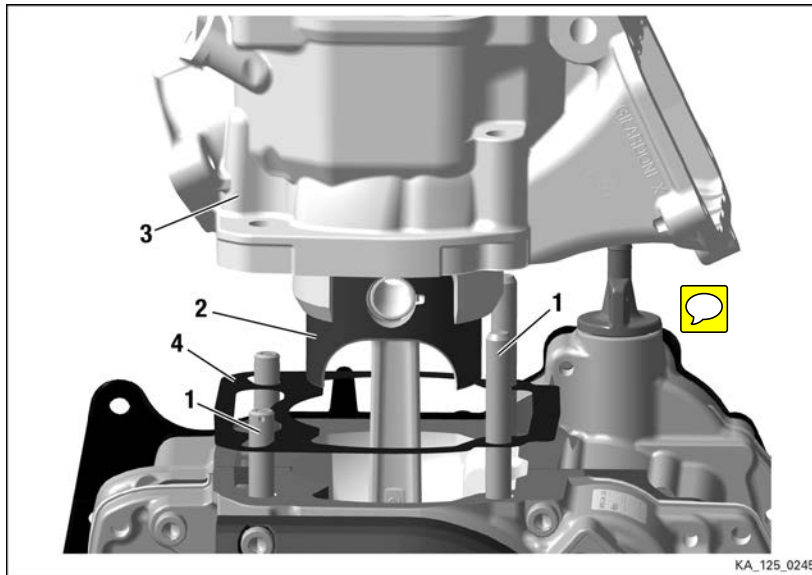

Figure 4.24: Cylinder head

1 Stud bolts  
3 Cylinder

2 Piston  
4 Gasket

## INSTALLATION OF THE EXHAUST SOCKET

### Special tools

The following special tools and equipment are required:

## Chapter 4

## BRP-Rotax REPAIR MANUAL

Part no.	Description	Field of application
297386	SILASTIC 732	Gasket

**Instructions** See [Figure: Exhaust socket](#). Proceed as follows to install the exhaust socket:

1. Coat both sides of the gasket with SILASTIC.
2. Fasten the exhaust socket (1) to the cylinder (5) with a new gasket (4) and 2 Allen screws M8x20 (3). Tightening torque 20 Nm (177 in.lb).
3. Check that the exhaust port is tightly seated on the cylinder.

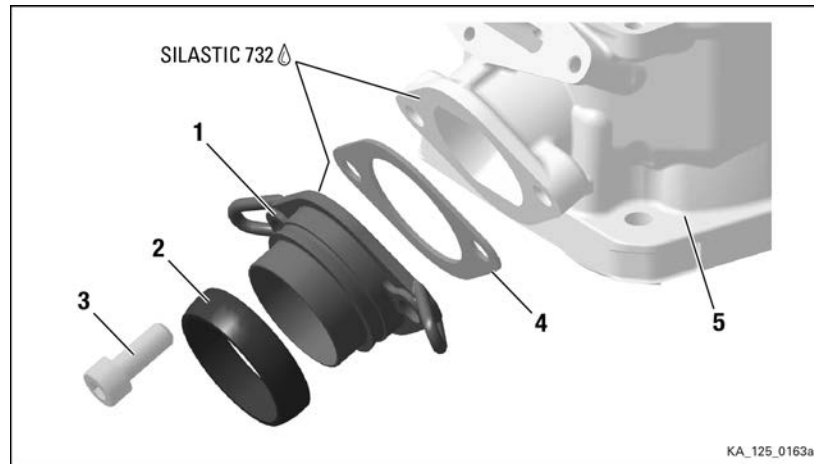

Figure 4.25: Exhaust socket

- |                               |                         |
|-------------------------------|-------------------------|
| <i>1 Exhaust socket assy.</i> | <i>2 Exhaust gasket</i> |
| <i>3 Allen screws M8x20</i>   | <i>4 Gasket</i>         |
| <i>5 Cylinder</i>             |                         |

### INSTALLATION OF THE CARBURETOR FLANGE AND REED VALVE

**Special tools** The following special tools and equipment are required:

Part no.	Description	Field of application
899788	LOCTITE 648	Screw locking

**Instructions** See [Figure: Carburetor flange and reed valve](#)  
Proceed as follows to install the exhaust socket:

## BRP-Rotax REPAIR MANUAL

### ATTENTION

The reed petal mounted on the reed valve must be fixed in precisely the correct installation position. Incorrect positioning of this valve leads to disturbed running of the engine due to incomplete combustion.

### ATTENTION

The reed petal is bent, not flat. It must be fixed with the concave facing the valve guide. If the valve guide with the correctly fitted reed valve is held up to the light, it must not be possible to see through it.

1. Attach the reed petal (2) and the valve detent (3) to the valve guide using recessed head screws (4). Use LOCTITE 648 to lock the screws.
2. Position the gasket (5) on the cylinder.
3. Position the reed valve (1) and intake socket (6) and fasten together with the support bracket (7) using 5 head screws M6x25 (8)(9). Tightening torque 7 Nm (62 in.lb).

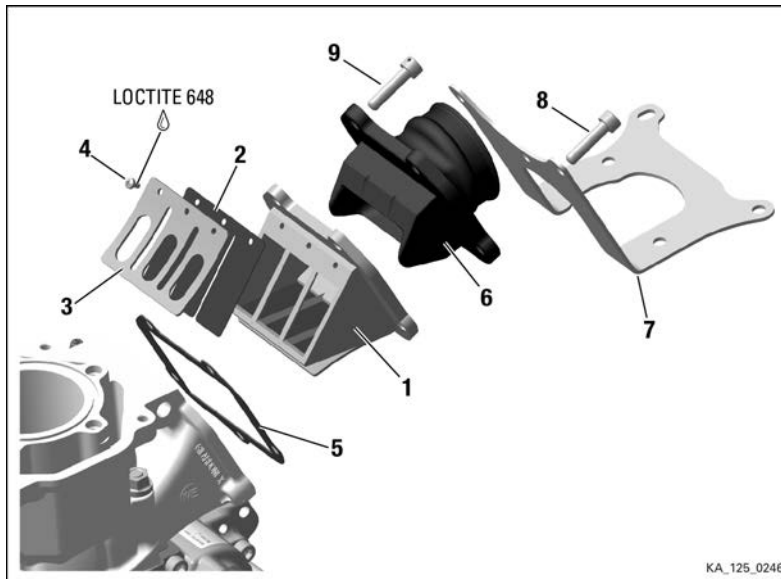

Figure 4.26: Carburetor flange and reed valve

- |                      |   |
|----------------------|---|
| 1 Reed valve         | 2 Reed petal  |
| 3 Valve detent       | 4 Recessed head screw M3x6                            |
| 5 Gasket             | 6 Carburetor flange                                   |
| 7 Support bracket    | 8 Allen screw M6x25, with hole for sealing the engine |
| 9 Allen screw M6x25, |   |

# BRP-Rotax REPAIR MANUAL

## INSTALLATION OF COMBUSTION CHAMBER INSERT

### General NOTE

Note the installation position of the combustion chamber insert (2) - "Made in Austria" points to the exhaust port.

### Instructions

See [Figure: Combustion chamber insert](#).

Proceed as follows to install the combustion chamber insert and cylinder head cover:

1. Position O-ring (2) in the groove of the cylinder.
2. Tighten combustion chamber insert (2) crosswise with 5 hex screws (4) and with lock washers (5) to 5 Nm initially, ensuring that the O-ring (3) is not crushed. Tighten to tightening torque 30 Nm (22 ft.lb).

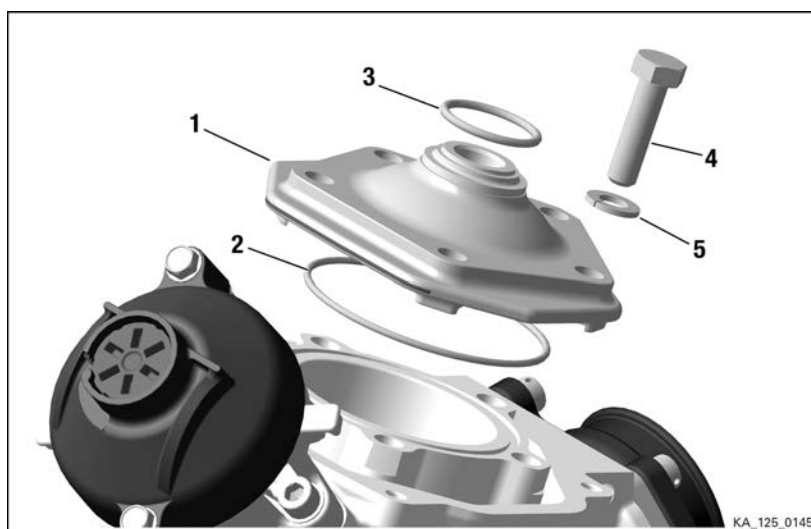

Figure 4.27: Combustion chamber insert

- |   |                           |   |                  |
|---|---------------------------|---|------------------|
| 1 | Combustion chamber insert | 2 | O-ring 64x2      |
| 3 | O-ring 23.3x2.4           | 4 | Hex. screw M8x30 |
| 5 | Lock washer               |   |                  |

## INSTALLATION OF CYLINDER HEAD COVER

### Special tools

The following special tools and equipment are required:

Part no.	Description	Field of application
897651	LOCTITE 243	Screw locking

### Preparation

The following preparation is required before installation:

- Installation of the coolant thermostat:

# BRP-Rotax REPAIR MANUAL

## Instructions

See [Figure: Coolant thermostat](#).

Installation of the coolant thermostat:

1. Install thermostat (2) with collar nut M8 (3), compression spring (4) and thermostat retaining bracket (5) with 2 screws (6). Lock screws with LOCTITE 243.

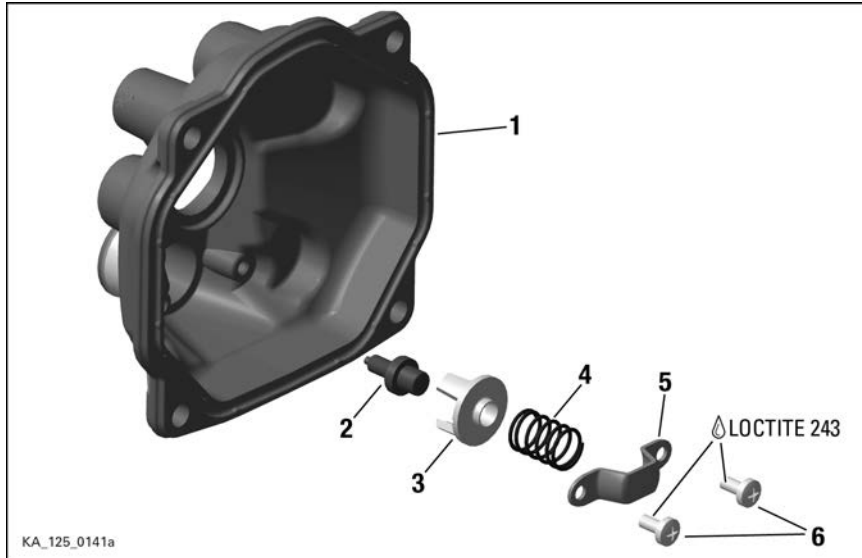

Figure 4.28: Coolant thermostat

- |   |                              |   |                              |
|---|------------------------------|---|------------------------------|
| 1 | Cylinder head cover red      | 2 | Thermostat 45 degree celcius |
| 3 | Collar nut M8                | 4 | Compression spring           |
| 5 | Thermostat retaining bracket | 6 | TAPTITE screw M4x8           |

## Instructions

See [Figure: Combustion chamber insert](#).

Proceed as follows to install the combustion chamber insert:

2. Position O-ring (1) on the combustion chamber insert.
3. Grease the O-ring (2) lightly to ensure that it adheres better to the groove of the cylinder head cover, otherwise fix it with sealant (Silastic).
4. Insert O-ring (2) into the groove of the cylinder head cover (3).
5. Tighten the cylinder head cover (3) crosswise with 4 Allen screws M6x25 (4). Tightening torque 10 Nm (90 in.lb).

## BRP-Rotax REPAIR MANUAL

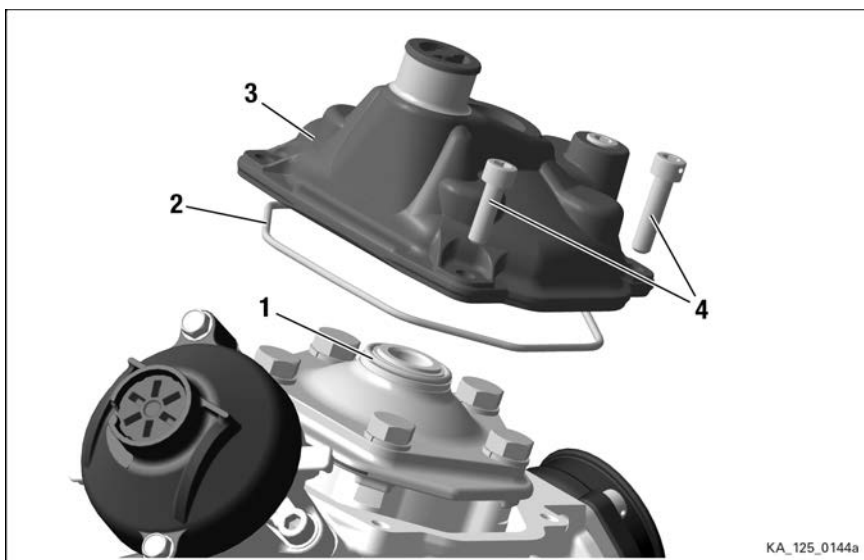

Figure 4.29: Combustion chamber insert

- |                           |                     |
|---------------------------|---------------------|
| 1 O-ring 23.3x2.4         | 2 O-ring 64x2       |
| 3 Cylinder head cover red | 4 Allen screw M6x25 |

### INSPECTION AND ADJUSTMENT OF SQUISH GAP

#### General

#### NOTE

*The gap between the piston (at the TDC of the piston) and the combustion chamber insert (= "squish gap") is partly responsible for the power characteristics of the engine and responsible for smooth running.*

#### NOTE

*The smaller the squish gap the higher the engine compression. This means that the engine response to the feed from the carburetor becomes more critical under changing operating conditions (temperature, air pressure, humidity).*

#### Special tools

The following special tools and equipment are required:

Part no.	Description	Use
580130	Solder 2 mm	Combustion chamber
580132	Solder 3 mm	Combustion chamber
n.a.	Vernier caliper	Solder

#### Instructions

See [Figure: Squish gap measurement](#).

1. Rotate crankshaft by hand until the piston is approx. 5 mm below TDC.

## BRP-Rotax REPAIR MANUAL

2. Right thickness of solder  
2.0 mm (for 125 MAX only)  
3.0 mm (for 125 Junior MAX only)  
bend as shown in the Figure: "Squish gap measurement" and insert through the spark plug thread into the combustion chamber until the solder is in contact with the cylinder wall.  
The squeeze edge must always be measured in the direction of the axis of the piston pin. Divergent measurements will show a wrong result!
3. Rotate the starter gear assembly by hand over the TDC position.

### NOTE

This will squeeze the solder between the piston and the combustion chamber insert.

4. Remove the solder from the combustion chamber and measure the thickness at the very end (= "squish gap") of the crushed end of the solder with a vernier calliper.

### NOTE

A vernier calliper with an accuracy of min. 1/100 mm is required for this measurement.

### ATTENTION

The squish gap must be within the specified tolerance.

You find the latest valid regulation on:  
<http://www.rotax-kart.com/de/Max-Challenge/MAX-Challenge/Regulations>.

### NOTE

*We recommend setting a squish gap in the upper tolerance range of the relevant model.*

### NOTE

*The squish gap can be set to a different thickness with cylinder base gaskets. Cylinder base gaskets are available 0.2 mm (0.008 in.), 0.3 mm (0.01 in.), 0.4 mm (0.015 in.), 0.5 mm (0.02 in.) and 0.8 mm (0.03 in.) thick.*

#### Engine model: 125 MAX – EXAMPLE

A cylinder base gasket 0.5 mm thick has been installed. With this cylinder base gasket a squish gap of 0.8 mm was measured. A cylinder base gasket 0.8 mm thick is required to set the required value, e.g. 1.1 mm.

Of course a 0.5 mm and a 0.3 mm seal can be installed.

If it is necessary to install a cylinder base gasket with a different thickness, the cylinder can be completely removed by unscrewing the four studs. Follow the instructions in section "Installation of the cylinder".

Keep in mind that the gasket will settle and reduce the squish over time.

## BRP-Rotax REPAIR MANUAL

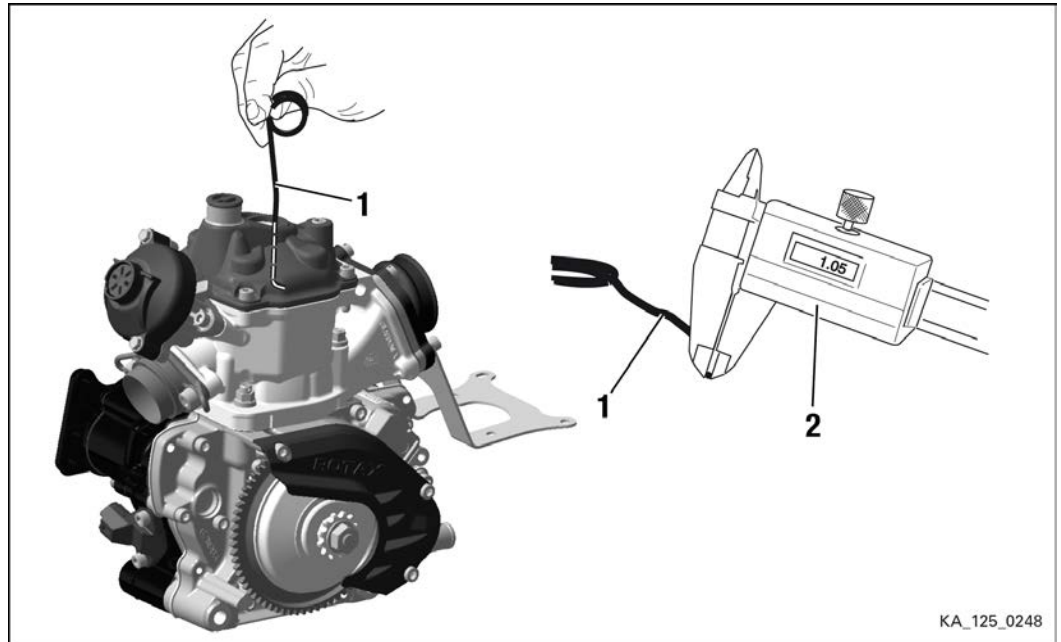

Figure 4.30: Squish gap measurement

1 Solder

2 Vernier caliper

### INSTALLATION OF SPARK PLUG

**Instructions** Proceed as follows to install the spark plug:

1. Screw in spark plug hand-tight and use tightening torque to tighten it with 27 Nm (20 ft.lb).

**BRP-Rotax**  
REPAIR MANUAL

NOTES

**BRP-Rotax**  
**REPAIR MANUAL**

**Chapter: Chapter 5**  
**CRANKCASE**

**TOPICS IN THIS CHAPTER**

<b>System description .....</b>	<b>2</b>
<b>Removal of the crankcase .....</b>	<b>5</b>
Drain oil .....	5
<b>Remove water pump and compensating wheels.....</b>	<b>6</b>
<b>Disassembling the crankcase.....</b>	<b>9</b>
<b>Removing bearing and oil seal for shaft .....</b>	<b>11</b>
<b>Installation of the crankshaft repair kit .....</b>	<b>15</b>
Disassembling of the crankshaft .....	15
Inspection of the crankshaft.....	19
Crankshaft not in specification .....	21
Crankshaft - assembly .....	22
<b>Crank case inspection .....</b>	<b>26</b>
Inspection of water pump drive .....	26
Inspection of water pump shaft .....	27
Inspection of balance shaft drive.....	27
Inspection of balance shaft.....	28
Inspection of the housing halves .....	29
<b>Crank case - assembly .....</b>	<b>30</b>
Installation of oil seal, ball bearing and needle bushing .....	30
Installation of Ball bearing and oil seal for crankcase .....	32
Assembly of crankshaft, water pump shaft and balance shaft.....	35
Assembly of the crankcase.....	36
<b>Installation of crankcase assy. ....</b>	<b>37</b>
Installation of balance and water-pump shaft drive .....	37

**Contents**            This chapter describes the disassembly and assembly of the crankcase of the ROTAX® 125 MAX evo (incl. Junior-, Mini-, Micro MAX evo) engine.

## **SYSTEM DESCRIPTION**

### Overview

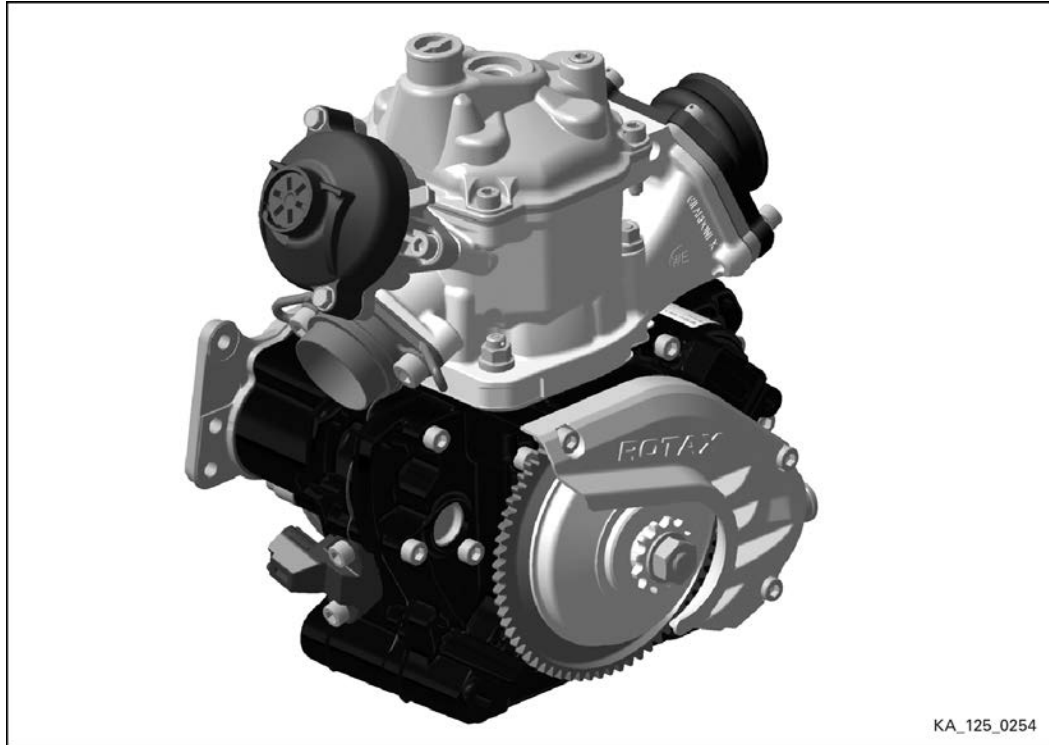

Figure 5.1: Position on the engine

# BRP-Rotax REPAIR MANUAL

## Overview

## Components of crankcase

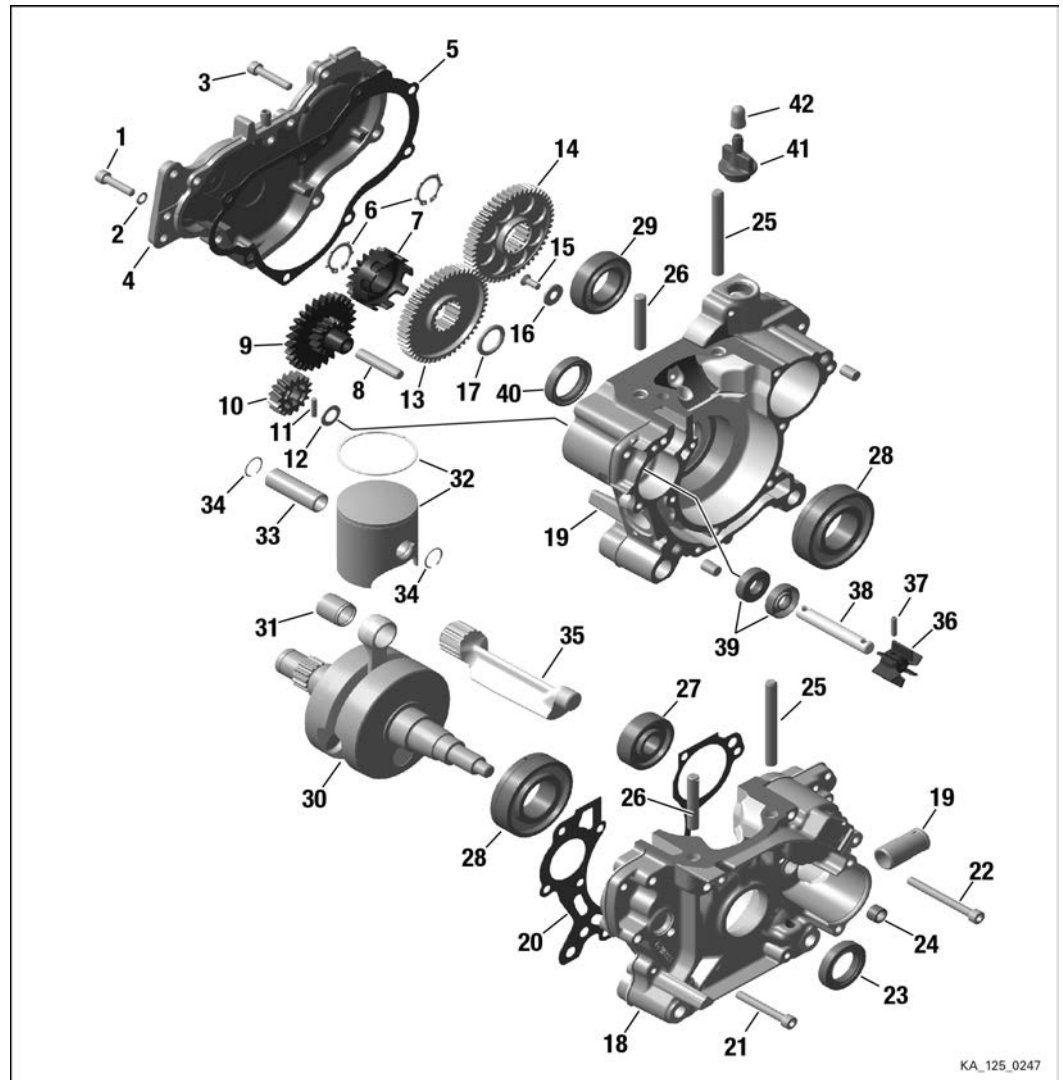

Figure 5.2

- |                              |                                  |
|------------------------------|----------------------------------|
| 1 Allen screw M6x25          | 2 Sealing ring A 6x10            |
| 3 Allen screw M6x30          | 4 Gearbox cover                  |
| 5 Gasket                     | 6 Retaining ring with lug 20x1.2 |
| 7 Water pump gear 19 T       | 8 Locating pin 8 small M6x40     |
| 9 Idle gear 28/13 T          | 10 Water pump pinion 16 T        |
| 11 Needle pin 4x15.8         | 12 Thrust washer 10.1/17/1       |
| 13 Balance gear (crankshaft) | 14 Balance gear (balance shaft)  |

## BRP-Rotax REPAIR MANUAL

---

15	<i>Countersunk screw M5x12</i>	16	<i>Thrust washer</i>
17	<i>O-ring 18x3.5</i>	18	<i>Crank case assy. black</i>
19	<i>Crank case assy.</i>	20	<i>Gasket</i>
21	<i>Allen screw M6x45</i>	22	<i>Allen screw M6x60</i>
23	<i>Oil seal AS 25x38x7</i>	24	<i>Needle bushing 8x12x8</i>
25	<i>Stud M8x57/20</i>	26	<i>Stud M8x28/20</i>
27	<i>Ball bearing 6302</i>	28	<i>Ball bearing 6206</i>
29	<i>Ball bearing 6005</i>	30	<i>Crankshaft assy.</i>
31	<i>Needle cage K 15x19x20</i>	32	<i>Piston assy.</i>
33	<i>Piston pin 15x10x12.5x45.6</i>	34	<i>Circlip 15</i>
35	<i>Balance shaft</i>	36	<i>Impeller</i>
37	<i>Dowel 4x16</i>	38	<i>Water pump shaft</i>
39	<i>Oil seal A 10x26x7</i>	40	<i>Oil seal AS 28x38x7</i>
41	<i>Air vent screw M18x1.5</i>	42	<i>Closure cap for impulse joint</i>



## REMOVAL OF THE CRANKCASE

### Safety information

**⚠ WARNING**

**Danger of severe burns and scalds! Always allow the engine to cool down to ambient temperature before starting any work.**



### Preparation

The following preparation is required before removal:

1. Removal of ignition system. See also Chapter 3).
2. Removal of the fuel line. See also Chapter 3).
3. Positioning the engine on the trestle mounting plate. See also Chapter 3).
4. Drain oil. See also Chapter 4).
5. Removal of cylinder head. See also Chapter 4).
6. Removal of carburetor. See also Chapter 6).
7. Removal of starter. See also Chapter 7).
8. Removal of radiator. See also Chapter 8).

### DRAIN OIL

#### Instruction

See [Figure: Drain oil](#).

1. Remove the Allen screw (3) with gasket (2) from the crankcase and gearbox case.
2. Drain the oil into a suitable vessel and dispose of it in the proper manner.



# BRP-Rotax REPAIR MANUAL

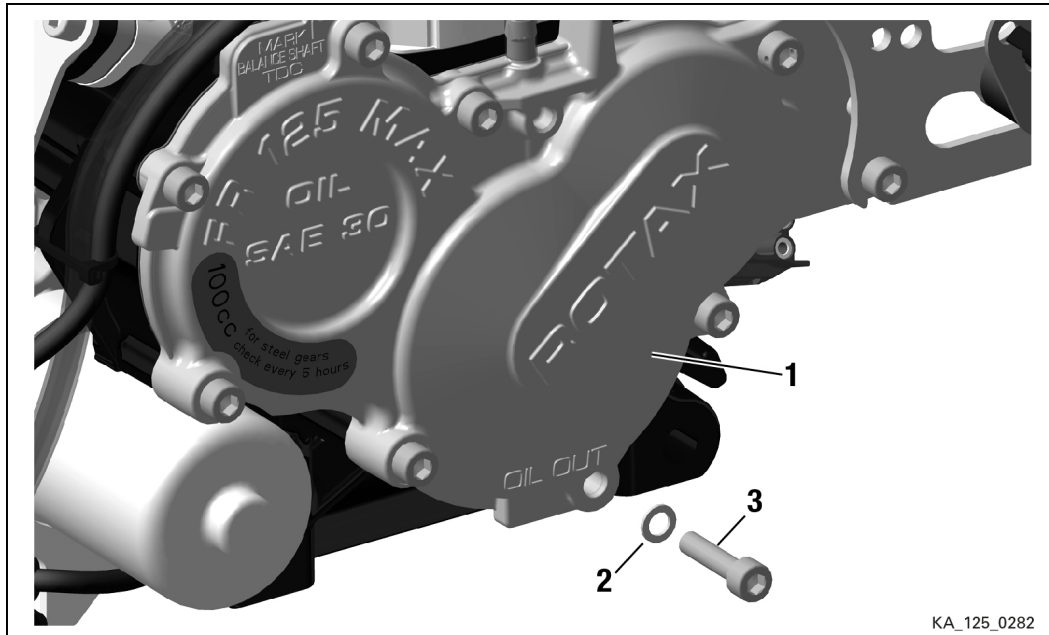

Figure 5.3: Drain oil

1 Gearbox cover

2 Sealing ring A6x10

3 Allen screw M6x25

## REMOVE WATER PUMP AND COMPENSATING WHEELS

### Special tools

The following special tools and equipment are required:

Part no.	Description	Use
n.a.	Circlip pliers	Drive wheel
n.a.	Hot-air gun	Compensating wheels

### Instructions

See [Figure: Gearbox cover](#).

1. Unscrew and remove Allen screws (1).
2. Remove gear cover (3) with gasket (4).

## BRP-Rotax REPAIR MANUAL

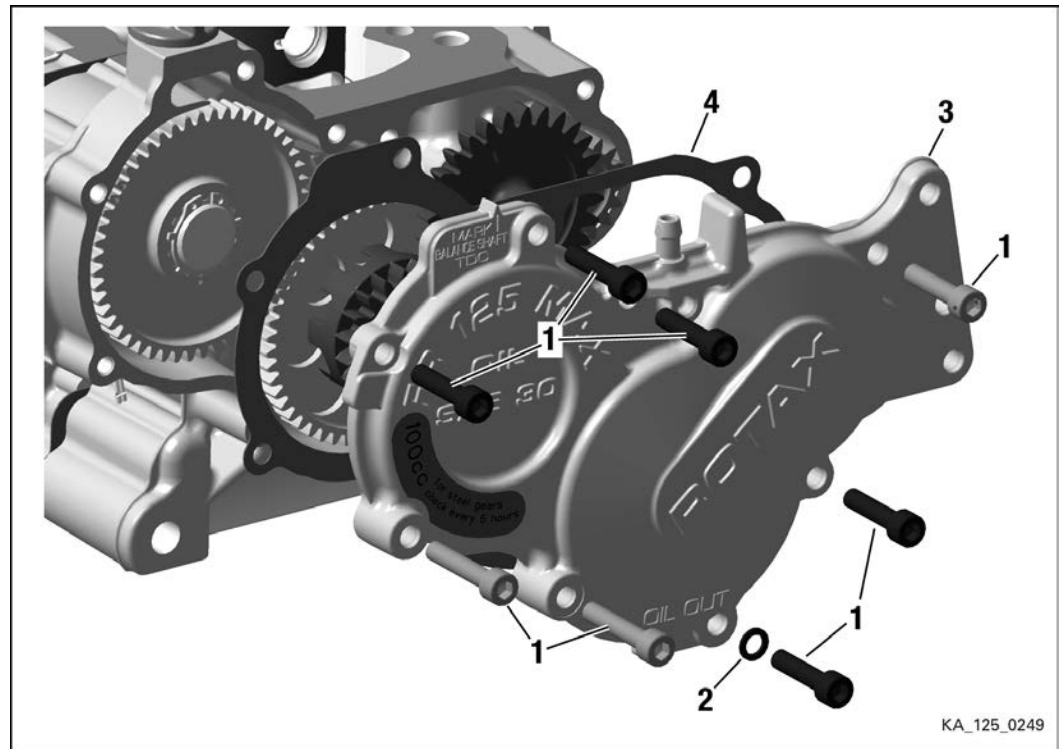

Figure 5.4: Gearbox cover

- |                |                       |
|----------------|-----------------------|
| 1 Allen screws | 2 Sealing ring A 6x10 |
| 3 Gear cover   | 4 Gasket              |



### Instruction

See [Figure: Water pump and balance shaft](#).

3. Remove water-pump pinion (2) and idle gear (5).
4. Remove needle pins (3) and thrust washer (4) from the water-pump shaft.
5. Remove retaining ring (5) with circlip pliers.
6. Remove the drive gear (9) from the crankshaft.
7. Heat balance gear (8,7) evenly with hot air if they do not move freely and remove them from crankshaft or balance shaft.
8. Remove O-ring (9) from the crankshaft.

**BRP-Rotax**  
**REPAIR MANUAL**

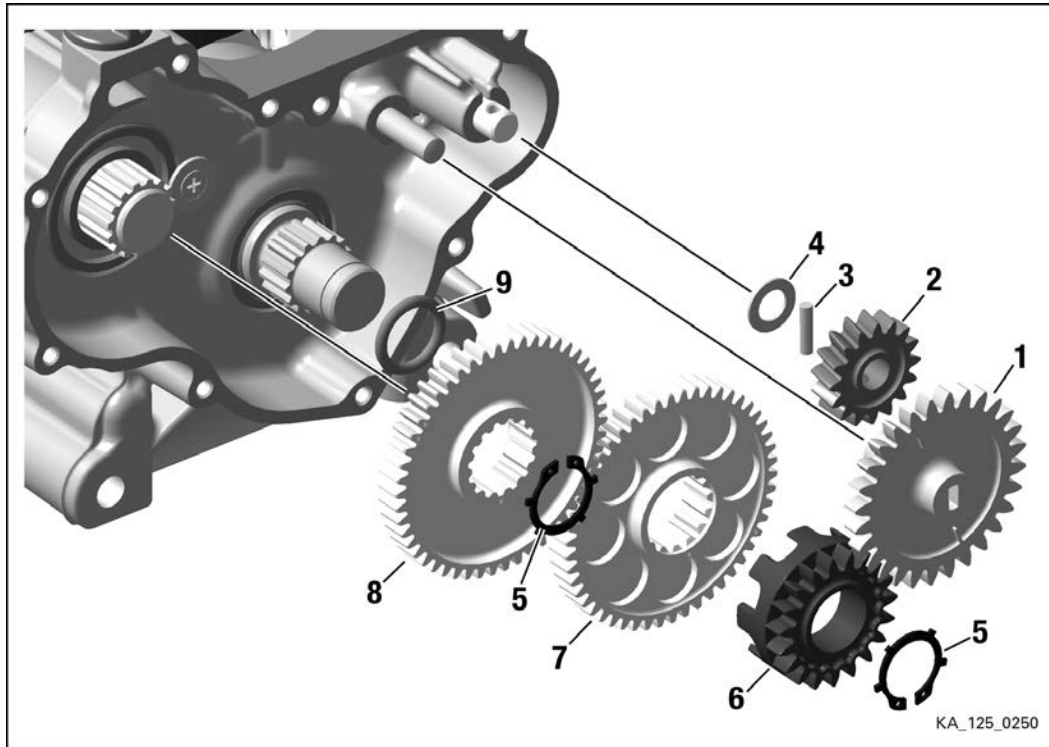

Figure 5.5: Water pump and balance shaft

- |                                  |                         |
|----------------------------------|-------------------------|
| 1 Idle gear 28/13 T              | 2 Water pump pinion 16T |
| 3 Needle pin 4x15.8              | 4 Thrust washer         |
| 5 Retaining ring with lug 20x1.2 | 6 Water pump gear 19 T  |
| 7 Balance gear 50 T              | 8 Balance gear 50T      |
| 9 O-ring 18x3.5                  |                         |

# BRP-Rotax REPAIR MANUAL



## DISASSEMBLING THE CRANKCASE

### Special tools

The following special tools and equipment are required:

Part no.	Description	Field of application
276016	Puller assembly	Case halves
n.a.	Plastic hammer	Crankshaft

### Instructions

See [Figure: Crankcase.](#)

#### NOTE

*Use two hex. screws to separate the case halves*

1. Unscrew all M6 case bolts and remove them.
2. Remove engine housing from trestle mounting plate.
3. Screw Allen screws (1,2) evenly into the extraction thread and press the case halves evenly apart.

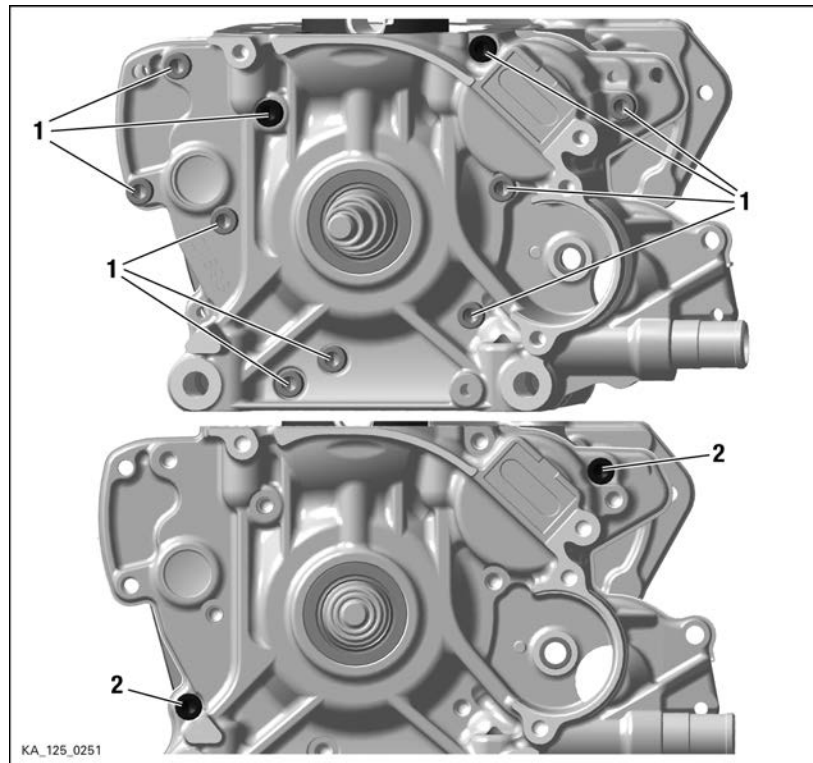

Figure 5.6: Crankcase

1,2 Allen screws

## BRP-Rotax REPAIR MANUAL

**Instruction** See [Figure: Balance shaft](#).

4. Remove gasket (2) from the case half (1).
5. Remove water-pump shaft (4).
6. Remove balance shaft (3) from the case.

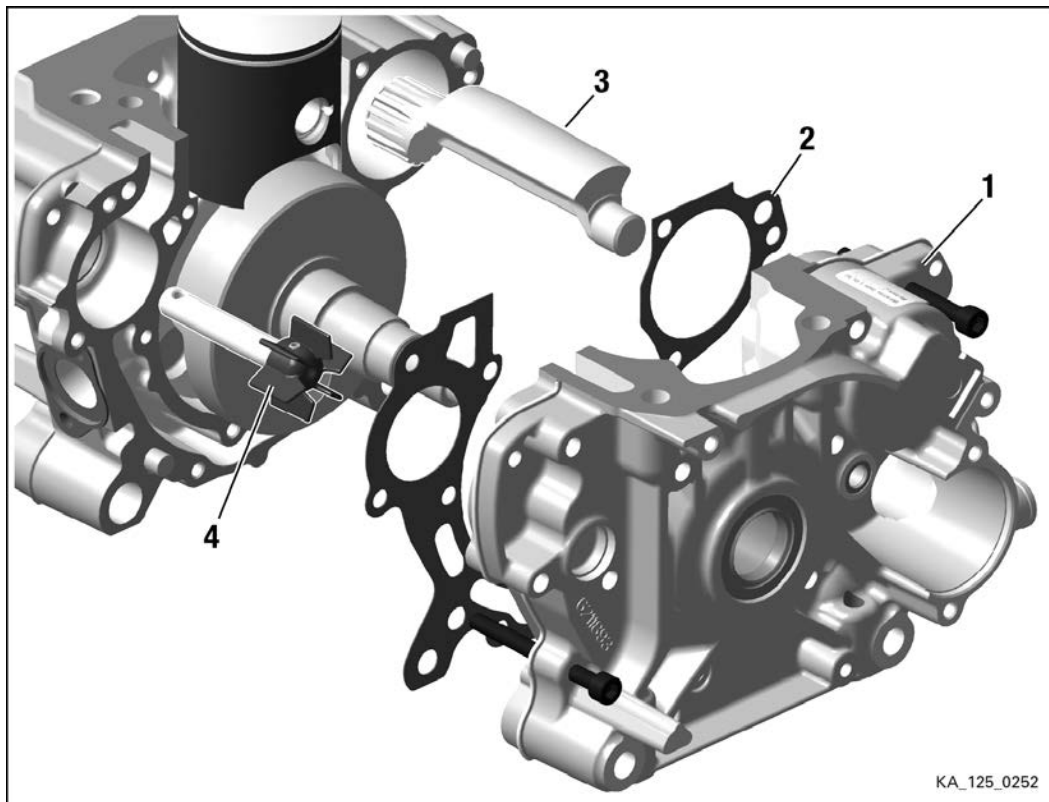

Figure 5.7: Balance shaft

- |   |                |   |                  |
|---|----------------|---|------------------|
| 1 | Crankcase half | 2 | Gasket           |
| 3 | Balance shaft  | 4 | Water pump shaft |

7. Gently tap the crankshaft (1) with the plastic hammer (3) to remove the crankshaft from the case half (2).

## BRP-Rotax REPAIR MANUAL

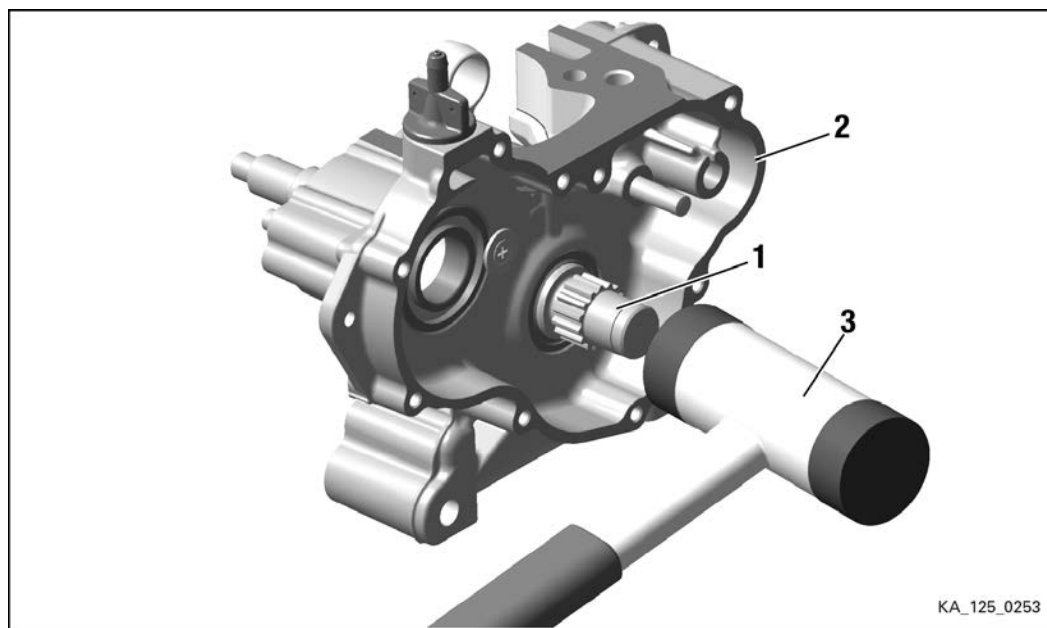

Figure 5.8: Crankcase

- 1 Crankshaft
- 3 Plastic hammer

- 2 Crankcase half



### REMOVING BEARING AND OIL SEAL FOR SHAFT

#### Special tools

The following special tools and equipment are required:

Part no.	Description	Use
n.a.	Convection oven	Case halves
676030	Installation tool	Needle bearing

#### Instructions

See [Figure: Bearing and oil seal for shaft](#).

1. Remove oil seal (1) and (2) from the two halves with suitable tools.
2. Remove oil seals (3) from water pump with suitable tools.
3. Remove pick up sensor (4) for the ignition system by removing the two Allen screws (5).
4. Remove air vent screw (6).
5. Remove countersunk screw (7) and thrust washer (8).
6. Heat the two halves of the case to approx. 150 °C in the convection oven until the bearing can be tapped gently out.

## BRP-Rotax REPAIR MANUAL

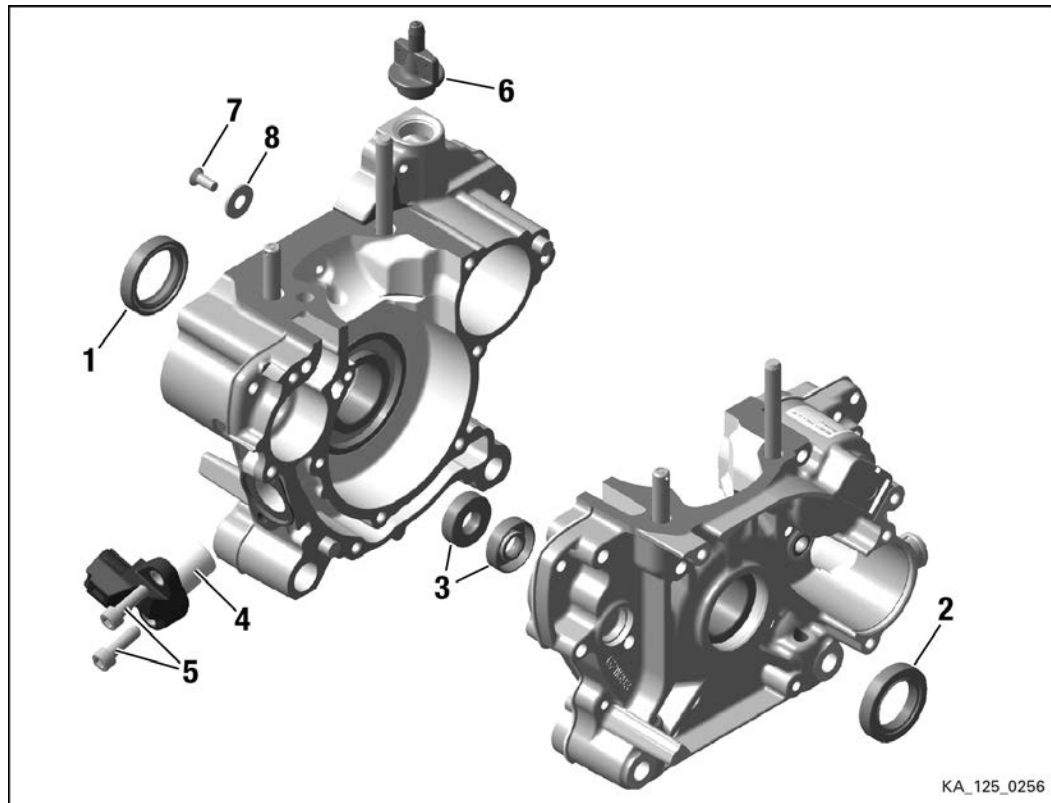

Figure 5.9: Bearing and oil seal for shaft

- |                           |                          |
|---------------------------|--------------------------|
| 1 Oil seal AS 28x38x7     | 2 Oil seal AS 25x38x7    |
| 3 Oil seal A 10x26x7      | 4 Pick up sensor         |
| 5 Allen screw M6x20       | 6 Air vent screw M18x1.5 |
| 7 Countersunk screw M5x12 | 8 Thrust washer          |

### **⚠ WARNING**

**Danger of severe burns and scalds!**  
Wear heat-resistant gloves during this process!

#### Clutch end case half

**Instruction** See [Figure: Clutch end case half](#).

7. Remove case half (1) from the convention oven and drop onto a flat wood board. This releases the ball bearing (2) of the crankshaft and the ball bearing (3) from the case.
8. Invert the case half and remove the needle bushing (5) with the installation tool (4).

## BRP-Rotax REPAIR MANUAL

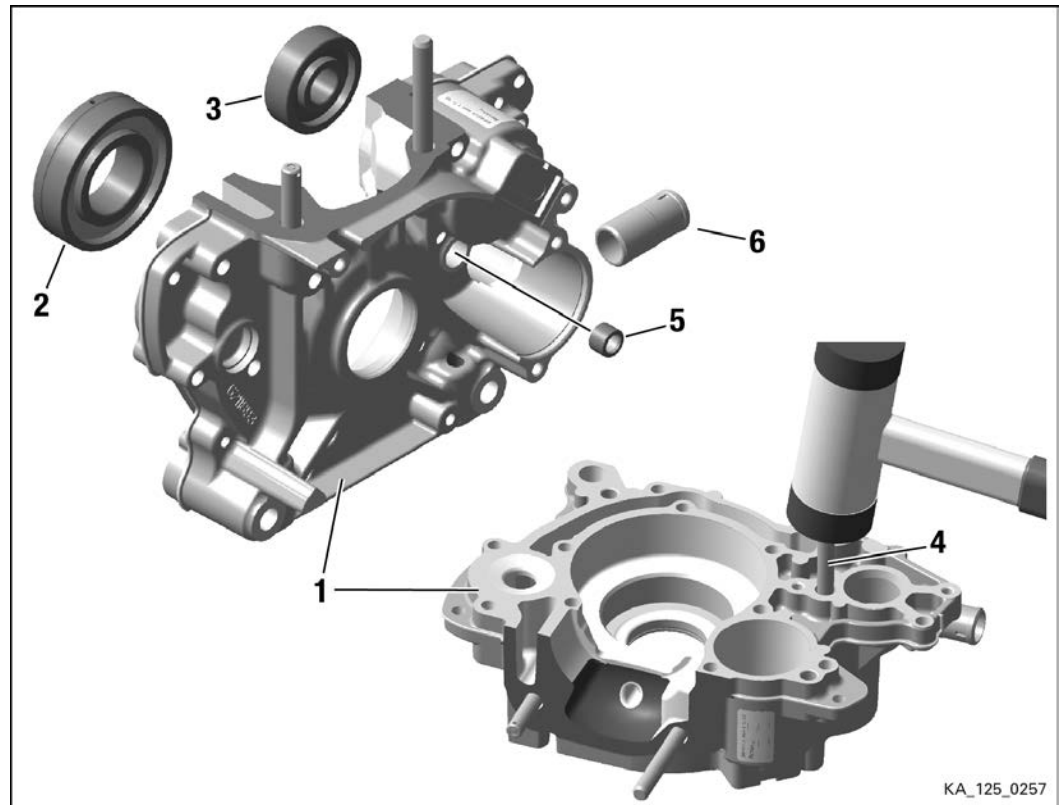

Figure 5.10: Clutch end case half

- |                         |                                     |
|-------------------------|-------------------------------------|
| 1 Crank case assy.      | 2 Ball bearing 6206                 |
| 3 Ball bearing 6302     | 4 Installation tool part no. 676030 |
| 5 Needle bushing 8x12x8 | 6 Tube                              |

### Ignition end case half

#### NOTE

The wooden board must have cutouts for the two dowels (1) and the locating pin (2) to form a flat base for the case half.

If it is necessary to replace the locating pin (2), it can be removed from the hot case with a pipe wrench.

**Instruction** See [Figure: Ignition side crankcase](#).

9. Remove case half (3) from the convection oven and drop onto a flat wood board with the case split pane. This removes the ball bearing (4,5) from the crankshaft and the balance shaft.
10. Allow both crankcase halves to cool to room temperature (20 °C) (274 °F).

# BRP-Rotax REPAIR MANUAL

## Instruction

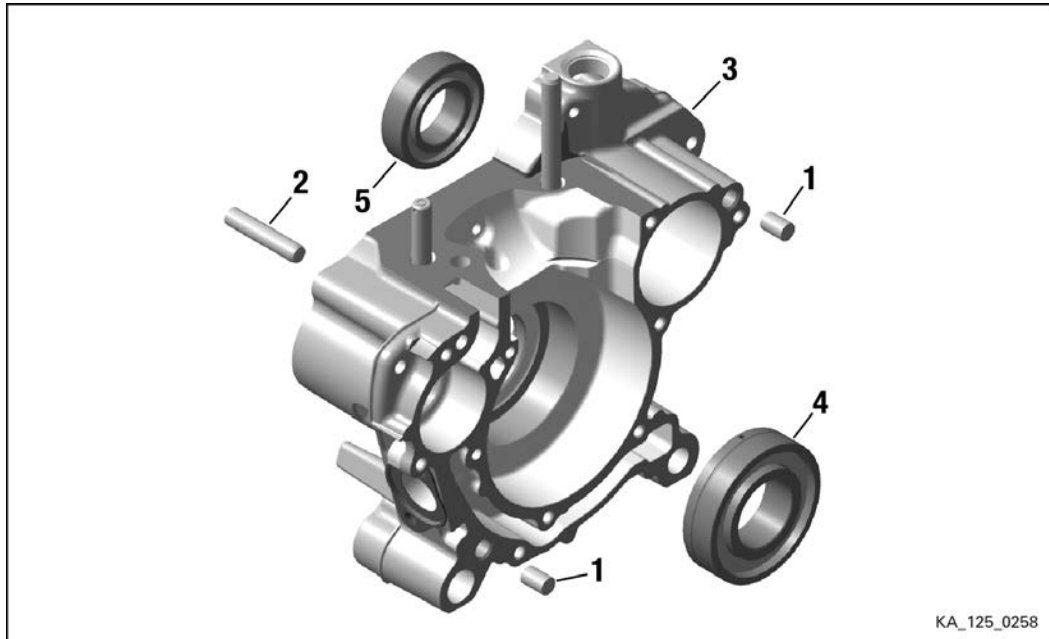

Figure 5.11: Ignition side crankcase

- |                     |                              |
|---------------------|------------------------------|
| 1 Pin 8x12          | 2 Locating pin 8 small M6x40 |
| 3 Crankcase assy.   | 4 Ball bearing 6206          |
| 5 Ball bearing 6005 |                              |



## INSTALLATION OF THE CRANKSHAFT REPAIR KIT

### DISASSEMBLING OF THE CRANKSHAFT

#### Safety instructions

#### WARNING

##### **Non-compliance can result in serious injuries or death!**

Be particularly careful when working with a tool such as a hydraulic press, and follow the instructions of the manufacturer. All repair and maintenance work must only be carried out by a qualified technician. Generally speaking, we advise to read manuals carefully and follow the instructions.

#### NOTE

*The parts of the crankshaft repair kit are paired together and must therefore be exclusively used together.*

#### NOTE

*Before disassembling the crankshaft, clean the parts thoroughly with a cleaning agent (grease-free).*

#### Special tools

The following special tools and equipment are required:

Part no.	Description	Field of application
n.a.	Press	Crankshaft disassembling
n.a.	Dial gauge	Crankshaft measurements
276051	crankshaft repair jig	Crankshaft

**BRP-Rotax**  
**REPAIR MANUAL**

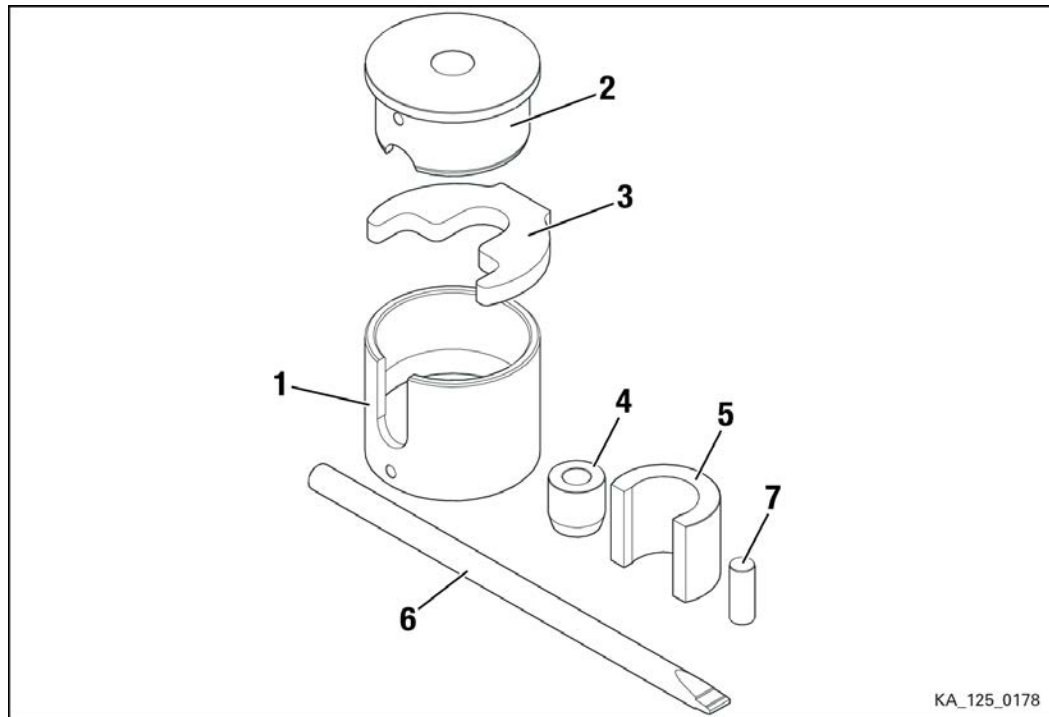

Figure 5.12: Crankshaft repair jig

Part	Part no.	Function
1	276051	Bottom section of the repair jig
2		Top section of the repair jig
3		Thrust plate
4		Sleeve
5		Thrust ring
6		Crowbar
7		Thrust pin/old piston pin

**NOTE**

*Con rod parts are not part of the crankshaft repair jig (part no. 276051).  
The crankshaft repair kit (con rod) is available at your ROTAX® Dealer.*

## BRP-Rotax REPAIR MANUAL

Part	Part no.	Description
685011		Crankshaft repair kit (1x)
consisting of:		
1	217431	Con rod (1x)
2	221162	Con rod pin (1x)
3	232884	Needle bearing (1x)
4	227731	Thrust washers (2x)

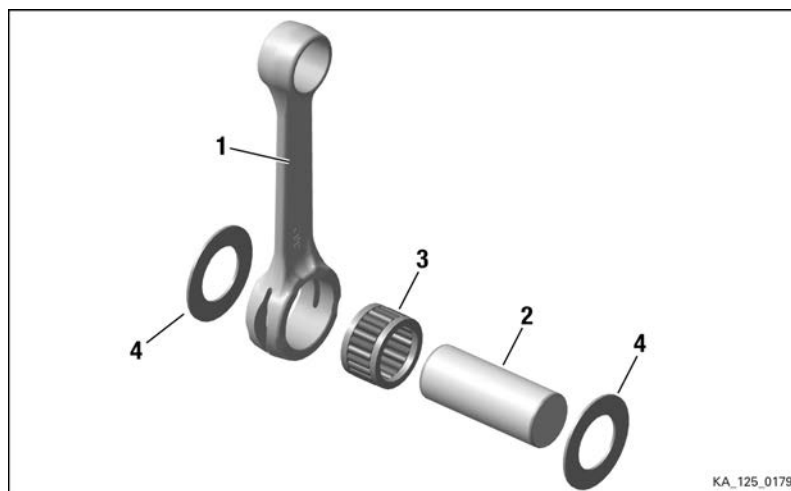

Figure 5.13: Con rod parts

- |                  |                      |
|------------------|----------------------|
| 1 Con rod        | 2 Con rod pin        |
| 3 Needle bearing | 4 Thrust washer (2x) |

### Instructions

See [Figure: Disassembling of the crankshaft](#).

### NOTE

*Position the con rod above the bore of the bottom of the crankshaft repair jig. Otherwise the con rod pin, the crankshaft half or the bottom section may be damaged.*

1. Push thrust plate (2) between the two halves of the crankshaft.
2. Position the crankshaft on the thrust plate (3) on bottom section of the tool (4) and make sure that the crankshaft matches the bore in the bottom section at the crankshaft repair jig (4).
3. Position the thrust pin (5) on the connecting rod pin and press the crankshaft apart.

## BRP-Rotax REPAIR MANUAL

### NOTE

Take an available con rod pin (6) and push the old con rod (7) with needle bearing and thrust washer onto the con rod pin. Note the installation instructions.

4. Take the gearbox-end of the crankshaft half (8) and repeat the procedure.

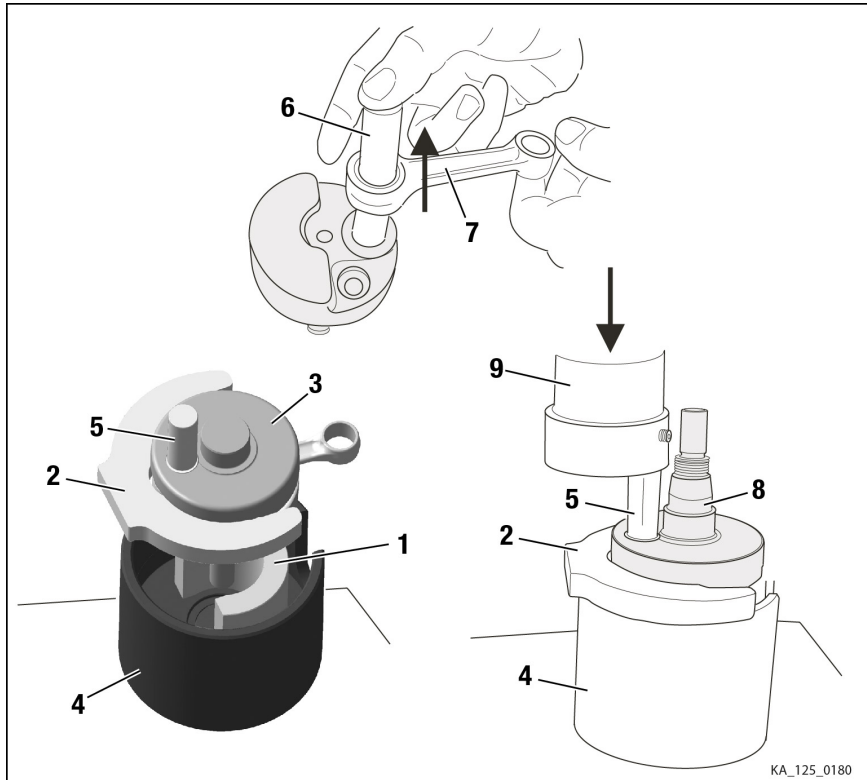

Figure 5.14: TYPICAL – Disassembling of the crankshaft

- |                   |   |
|-------------------|---|
| 1 Thrust ring     | 2 Thrust plate                                |
| 3 Crankshaft half | 4 Bottom section of the crankshaft repair jig |
| 5 Thrust pin      | 6 Con rod pin                                 |
| 7 Con rod         | 8 Drive side of the crankshaft half           |
| 9 Press           |   |

# BRP-Rotax REPAIR MANUAL

## INSPECTION OF THE CRANKSHAFT

### General

- Thoroughly clean the crankshaft with a grease-free cleaning agent.

### Instructions

See [Figure: Crankshaft measurements](#).

1. Inspect the crankshaft for visible damage and traces of wear:
  - Cone/centered thread
  - Bearing seats
  - Running surface of the bearing
  - Contact surface of the shaft seals
  - Woodruff key groove

### Measuring the crankshaft

2. Measure values for the two main bearing seats (CS01), the bearing surface of the clutch (CS02) and of the piston pin (CS03).
3. Determine the axial play of the con rod bearing (CS04) using a feeler gauge.
4. Check the specific dimension (CS07).
5. Determine the radial clearance of the connecting rod bearing (CS05).
6. Check the run out of the crankshaft (CS06).

#### NOTE

*If one of the wear limits CS01 or CS02 is reached, the complete crankshaft must be replaced.*

#### NOTE

*If one of the wear limits CS03, CS04 or CS05 is reached, BRP-Rotax recommends use of the applicable repair kit. See also Chapter 5 Figure: Con rod parts.*

#### NOTE

*If the maximum approved stroke (CS06) of the crankshaft is exceeded, the crankshaft must be realigned. See also Chapter 5 Figure: Crankshaft measurements.*

**BRP-Rotax**  
**REPAIR MANUAL**

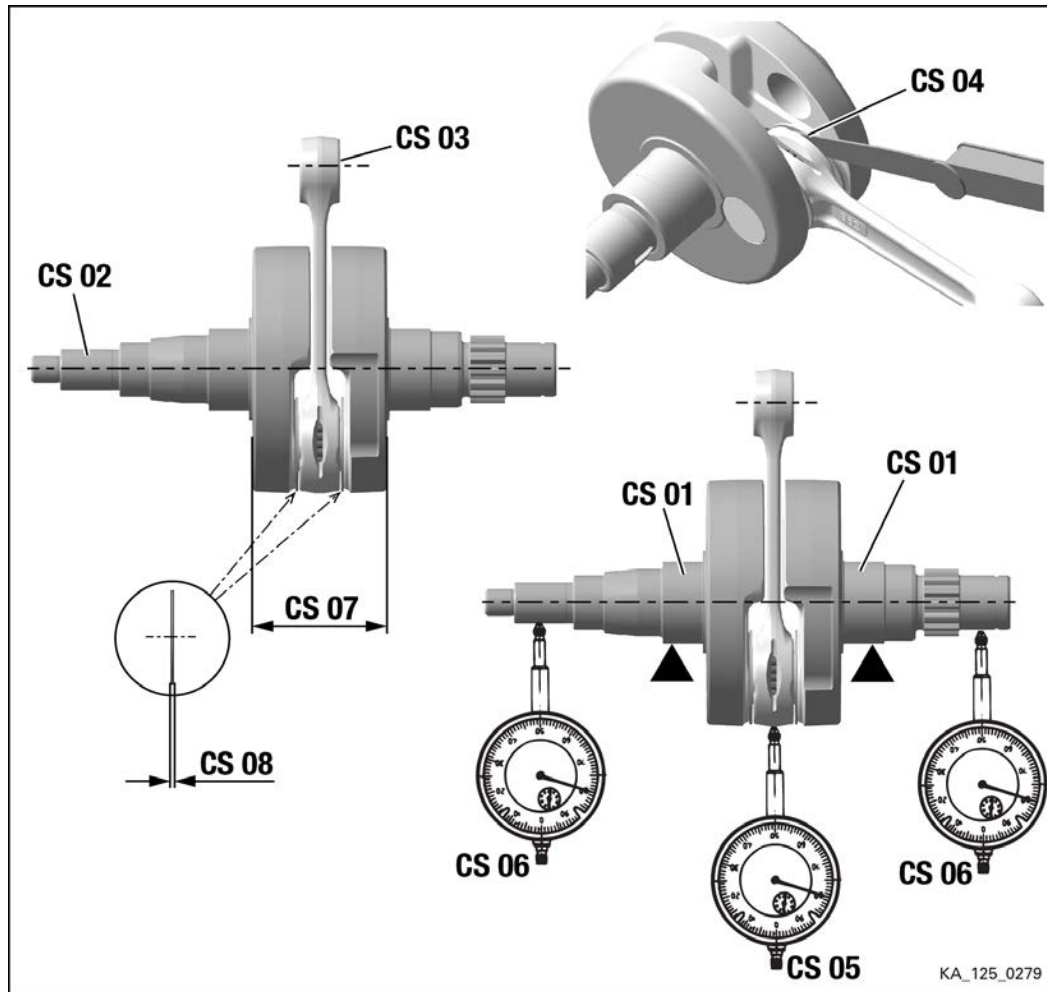

Figure 5.15

Description	Code	New dimension	Wear limit
Main bearing seat	CS01	29.980 mm - 29.995 mm	29.94 mm
Clutch bearing seat	CS02	14.98 mm - 15.003 mm	14.95 mm
Piston pin bearing seat	CS03	18.99 mm - 19.005 mm	19.015 mm
Conrod bearing axial play	CS04	1.0 mm	1.3 mm
Conrod bearing radial play	CS05	0.05 mm	0.08 mm
Stroke of crankshaft	CS06	0.0 mm - 0.015 mm	0.03 mm

## BRP-Rotax REPAIR MANUAL

Description	Code	New dimension	Wear limit
Distance of crank webs	CS07	48.95 mm - 49.05 mm	49.05 mm
Thrust washer thickness	CS08	1.0 mm	0.85 mm

### CRANKSHAFT NOT IN SPECIFICATION

#### General

#### NOTE

*If the crankshaft is not 100% aligned or exceeds the tolerance, the crankshaft must be re-aligned. See CS 07.*

#### Special tools

The following special tools and equipment are required:

Part no.	Description	Field of application
276051	Crankshaft repair jig	Crankshaft
n.a.	Vise	

#### Instructions

See [Figure: Aligning the crankshaft](#).

- To align the crankshaft, clamp the drive end or engine end of the crankshaft half (1) in a vise (2). Use a soft material to cover the crankshaft inside the vise to protect the surface.
- Use the lever (3) to lift up the upper half of the crankshaft.

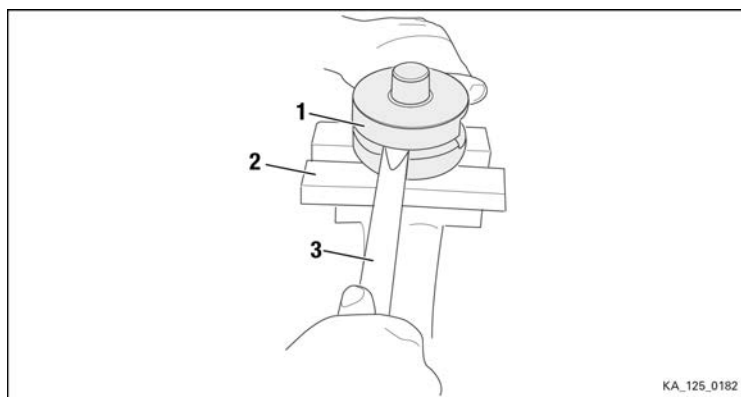

Figure 5.16: Aligning the crankshaft

- 1 Crankshaft half  
3 Crowbar

2 Vise

- The crankshaft can be aligned to the external diameter of the crankshaft webs with target strokes of an aluminum hammer.

# BRP-Rotax REPAIR MANUAL

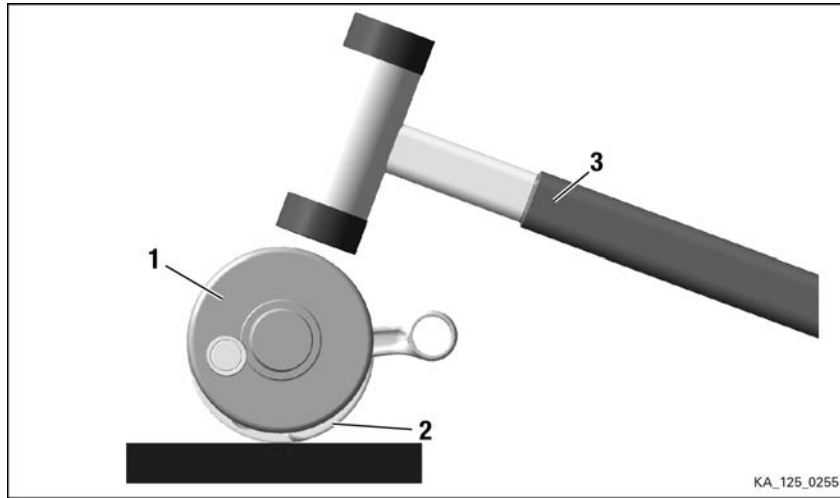

Figure 5.17: Aluminum hammer

1 Crankshaft half



2 Crankshaft

3 Aluminum hammer

## CRANKSHAFT - ASSEMBLY

### General

#### NOTE

*Clean the bore for the connecting rod pins of the gearbox-side crankshaft half with a cleaning agent (grease-free).*

### Special tools

The following special tools and equipment are required:

Part no.	Description	Field of application
n.a.	Press	Crankshaft
276051	Crankshaft repair jig	Crankshaft
899788	LOCTITE 648	Crank pin

### Instructions

See [Figure: Crankshaft assembly](#).

1. Apply LOCTITE 648 to the inside of the crank pin bore in both crankshaft halves.

#### NOTE

Remove excess LOCTITE after pressing in, otherwise adjacent parts may be damaged.

2. Insert the new con rod pin (5) into the crankshaft bore.
3. Place the sleeve (6) over it.

## BRP-Rotax REPAIR MANUAL

### NOTE

Transfer the new con rod from the old con rod pin to the pressed-in (new) con rod pin in the crankshaft repair jig. (note the installation position).

4. Position the drive end crankshaft half (3) on the thrust plate (2) and press the new con rod pin (5) into the crankshaft until the con rod pin stops moving, then remove the sleeve (6).
- 5.

### NOTE

Before positioning the con rod on the pressed-in con rod pin check for:

- no corrosion damage
- no dirt or dust particles
- check that all bearing needles are present

Slide the new crankshaft assy. (7) with cage from the con rod pin (mounting device) onto the pressed-in con rod pin (5).

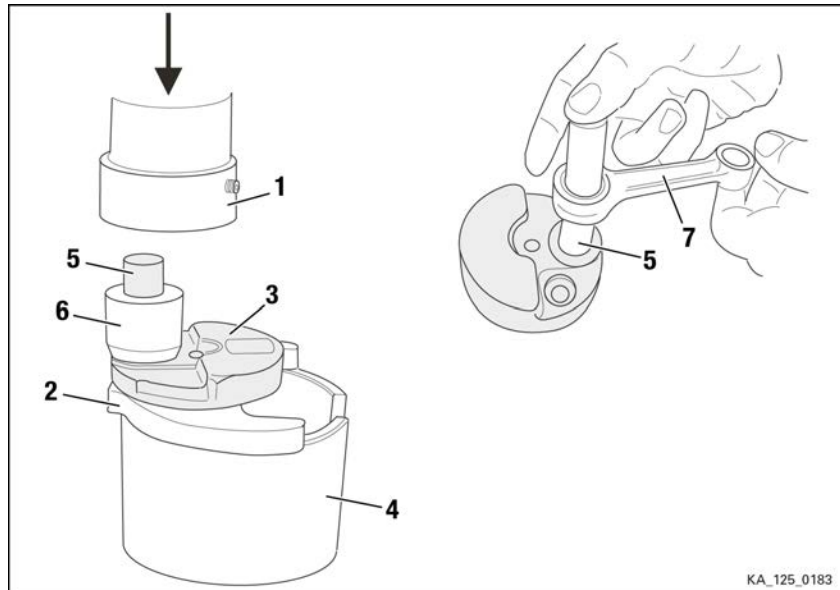

Figure 5.18: Crankshaft assembly

- |                             |                                    |
|-----------------------------|------------------------------------|
| 1 Press                     | 2 Thrust plate                     |
| 3 Drive end crankshaft half | 4 Bottom section of the repair jig |
| 5 Con rod pin               | 6 Sleeve                           |
| 7 Crankshaft                |                                    |

**Instructions** See [Figure: Crankshaft assembly](#).

6. Slide the gearbox-end crankshaft half (1) into the bottom section of the tool (2).

## BRP-Rotax REPAIR MANUAL

7. Clean the drive end crankshaft web hole with cleaning agent (grease-free).
8. Coat the hole with LOCTITE 648.

### NOTE

Remove excess LOCTITE, otherwise the con rod may be damaged.

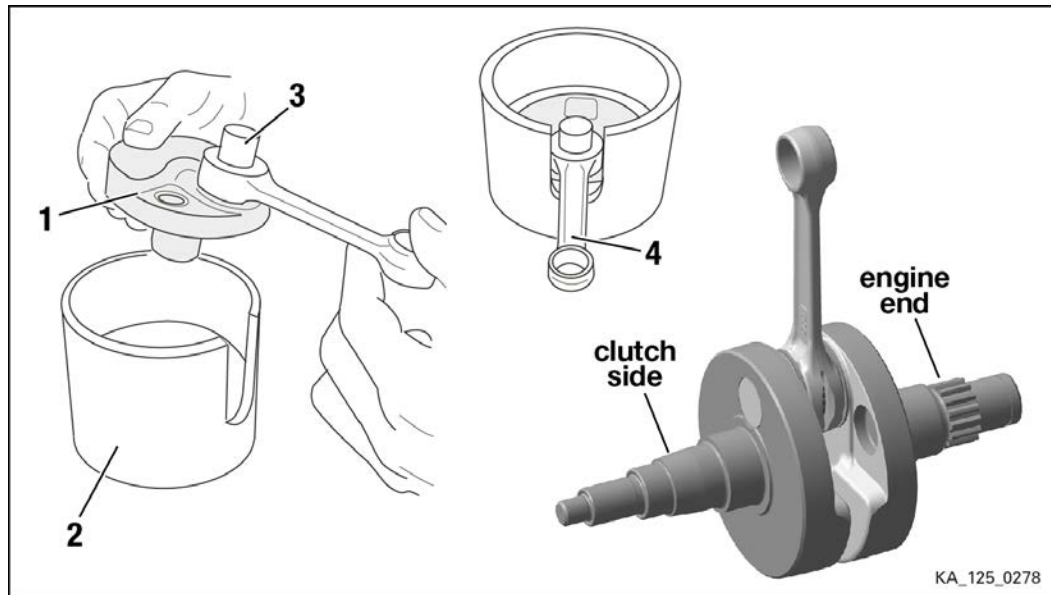

Figure 5.19

- |                                |                                    |
|--------------------------------|------------------------------------|
| 1 Crankshaft half (engine end) | 2 Bottom section of the repair jig |
| 3 Con rod pin                  | 4 Con rod                          |

9. Slide the drive-end crankshaft half (1) into the top section of the repair jig (2).
10. Hold the crankshaft half as shown in following Figure and push the top section of the tool (3) into the bottom section of the tool (2).

### NOTE

A rotary movement of the con rod makes it easy to align the web hole with the con rod pin.

11. Position the thrust ring (4) on the top section of the repair jig and press the two crankshaft halves together (until the crankshaft pin is aligned with the crankshaft web).

## BRP-Rotax REPAIR MANUAL

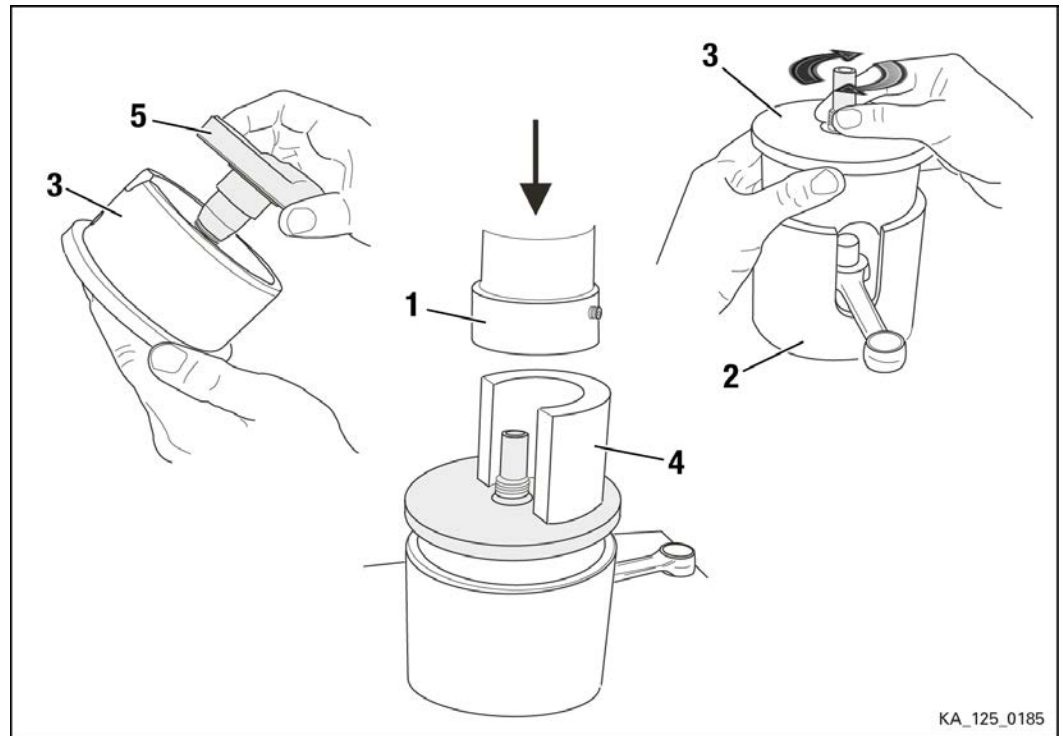

Figure 5.20: Crankshaft assembly

- |                                 |                                    |
|---------------------------------|------------------------------------|
| 1 Press stamp                   | 2 Bottom section of the repair jig |
| 3 Top section of the repair jig | 4 Thrust ring                      |

## CRANK CASE INSPECTION

### INSPECTION OF WATER PUMP DRIVE

**General**

**NOTE**

*If the edges of the idle gear teeth (1) or the water pump pinion (2) show signs of wear, both gears must be replaced.*

**Instructions**

See [Figure: Water pump drive](#).

1. Inspect water pump gear (1), idle gear (2) and water pump pinion (3) for cracks (visual inspection).
2. Inspect the teeth of the idle gear (2) and the water pump pinion (3) for wear.
3. Inspect the hole and the two axial surfaces of the idle gear (2) for signs of wear.

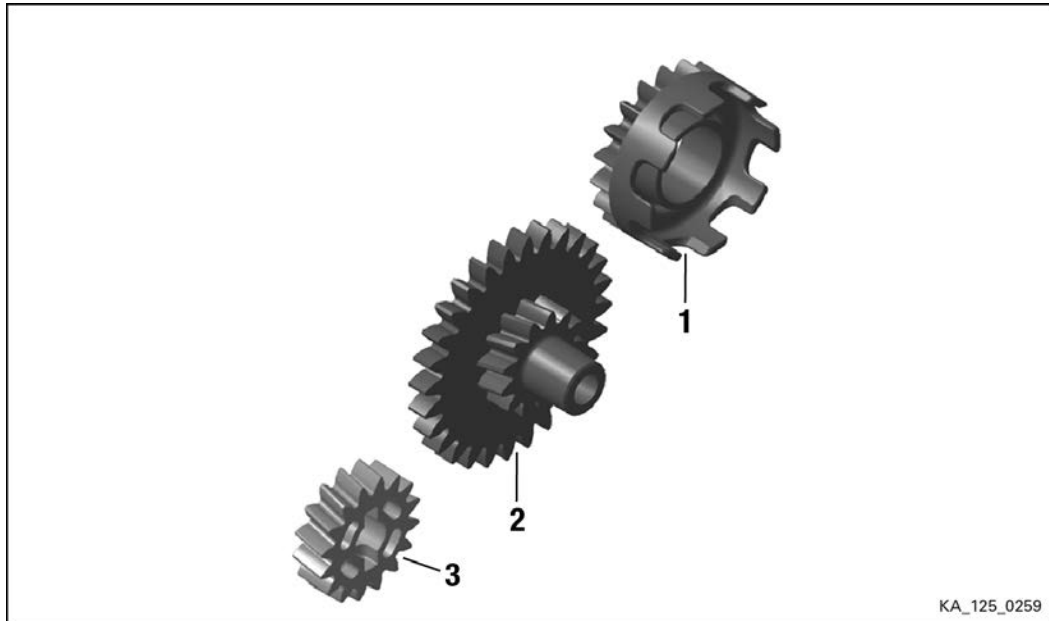

Figure 5.21: Water pump drive

1 Water pump gear 19 T

2 Idle gear 28/13 T

3 Water pump pinion 16 T

# BRP-Rotax REPAIR MANUAL

## INSPECTION OF WATER PUMP SHAFT

**Instruction** See [Figure: Water pump shaft](#).

1. Check the water pump shaft in the areas around the two shaft seal rings; if it is excessively worn it must be replaced.
2. Check the impeller for damage and/or any abnormal deformation, and replace it if necessary.

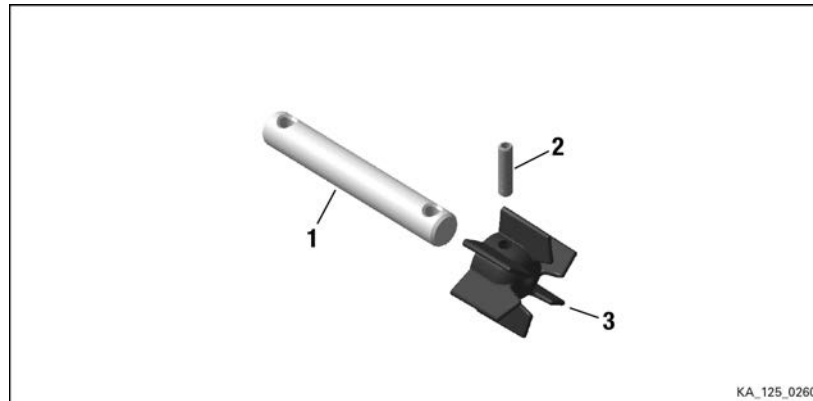

Figure 5.22: Water pump shaft

1 Pump shaft

2 Dowel 4x16

3 Impeller

## INSPECTION OF BALANCE SHAFT DRIVE

**General** **NOTE**

*If one of the balance wheels has cracks or if backlash of the balance wheels at the spline can be seen, both balance wheels must be replaced.*

**Instructions** See [Figure: Balance shaft drive](#).

1. Check balance gears (1) for cracks.
2. Place balance gears on the spline, the balance shaft or crankshaft and inspect balance gears for backlash at the spline.
3. Check outer teeth of the two balance gears for signs of wear. If the teeth of one of the balance gears shows signs of wear, both balance gears must be replaced.
4. Inspect condition of O-ring (2).

**NOTE**

The balance gears (1) and the O-ring (2) should be replaced at least every 50 operating hours.

# BRP-Rotax REPAIR MANUAL

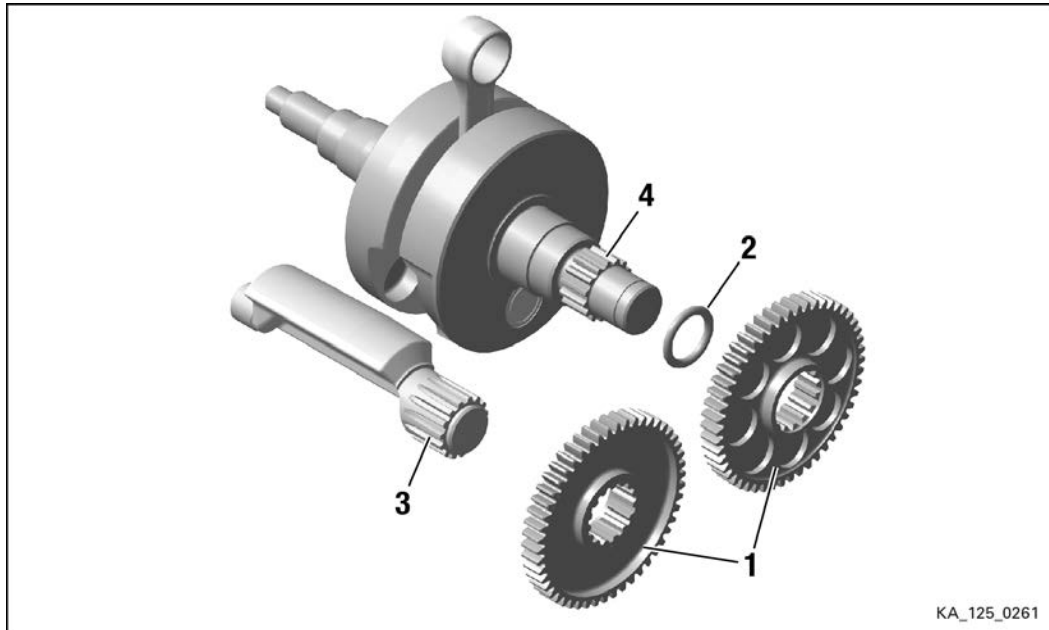

Figure 5.23: Balance shaft drive

- |                     |                    |
|---------------------|--------------------|
| 1 Balance gear 50 T | 2 O-ring 18x3.5    |
| 3 Balance shaft     | 4 Crankshaft assy. |

KA\_125\_0261

## INSPECTION OF BALANCE SHAFT

### General

#### NOTE

*If one of the wear limits BS10 or BS11 is reached, the balance shaft must be replaced.*

### Instructions

See [Figure: Balance shaft](#)

1. Inspect the groove (3) for the locking ring for damage and wear.
2. Check the diameter of the bearing seats BS10 and BS11 for wear.

Description	Code	New dimension	Wear limit	Measured value
Main bearing seat	BS10	14.96 mm - 14.99 mm	14.94 mm	
Clutch bearing seat	BS11	24.97 mm - 24.99 mm	24.94 mm	

## BRP-Rotax REPAIR MANUAL

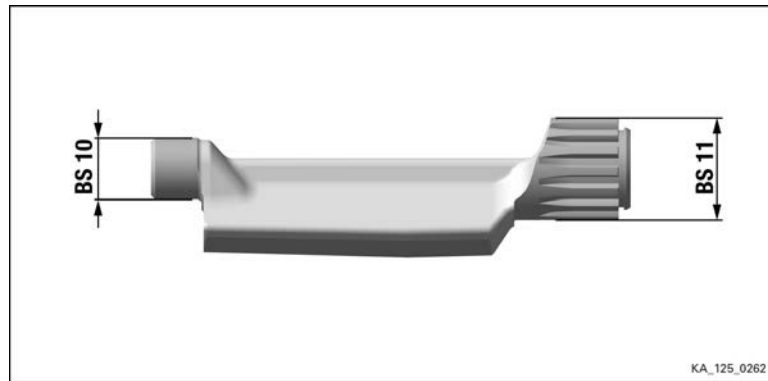

Figure 5.24: Balance shaft

### INSPECTION OF THE HOUSING HALVES

**Instructions** See [Figure: Crankcase](#).

1. Clean both case halves with commercial detergents.
2. Check both halves (1) for cracks and damage (visual inspection).
3. Check sealing surfaces (2) for damage (visual inspection).
4. Check threads (3) for cleanliness and clearance.
5. Check that lubrication holes (4) are open and clean with compressed air as required.

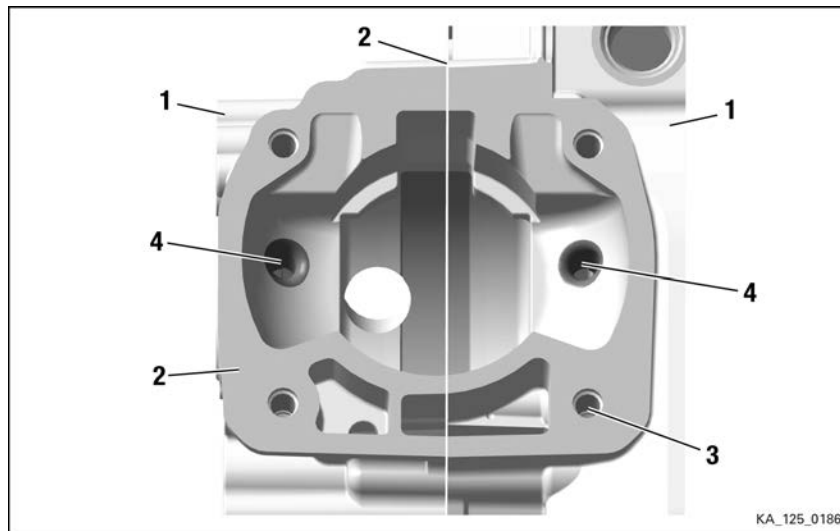

Figure 5.25: Crankcase

1 Case halves

2 Sealing surfaces

3 Thread

4 Main bearing lubrication hole

**BRP-Rotax**  
**REPAIR MANUAL**

**CRANK CASE - ASSEMBLY**

**General**

**NOTE**

*Always replace old gaskets, circlips, O-rings and oil seals with new ones after disassembling.*

**Special tools**

The following special tools and equipment are required:

Part no.	Description	Use
n.a.	Convection oven or heating plate	Case halves
676030	Installation tool	Needle bearing
676010	Mounting sleeve	Shaft seal
676021	Installation tool	
n.a.	2-stroke engine oil	Shaft seal
n.a.	MOLYCOTE 111	Shaft seal

**INSTALLATION OF OIL SEAL, BALL BEARING AND NEEDLE BUSHING**

**⚠ WARNING**

**Danger of severe burns and scalds!**  
Wear heat-resistant gloves during this process!

**Instruction**

See [Figure: Oil seal installation](#).

1. Heat both crankcase halves to 150 °C (302 °F) in the convection oven.
2. Remove case half from the convection oven and drop onto a flat wood board with the case split pane.
3. Coat the oil seal AS 28x38x7 (1) with engine oil in the area between the sealing lip and dust lip.
4. Press in the oil seal for shaft to the stop with the mounting sleeve (part no. 676010) from inside to outside so the open end of the oil seal for shaft is directed inward.

**NOTE**

The oil seal for shaft can also be installed from outside to inside if the crankshaft is installed.

## BRP-Rotax REPAIR MANUAL

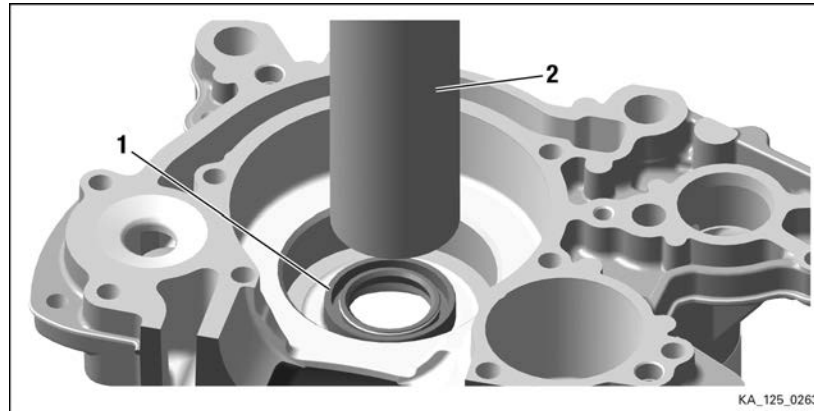

Figure 5.26: Oil seal installation

1 Oil seal AS 28x38x7

2 Mounting tool part no. 676010

### Instruction

See [Figure: Ball bearing](#).

5. Slide the ball bearing (1) of the crankshaft into the crankcase half to the limit stop so the closed side of the cage is facing to the crankshaft.

### NOTE

The labeling of the ball bearing must be visible!

6. Slide the ball bearing (2) of the balance shaft into the crankcase half to the limit stop so the closed side of the cage is facing to the balance shaft.

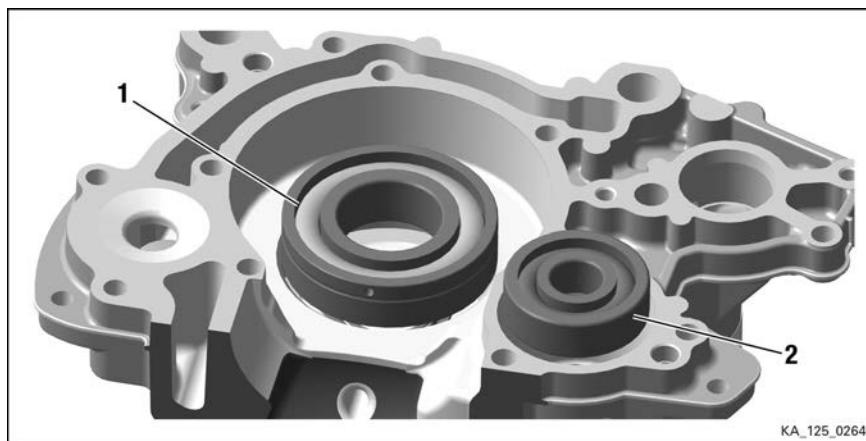

Figure 5.27: Ball bearing

1 Ball bearing 6206

2 Ball bearing 6302

## BRP-Rotax REPAIR MANUAL

**Instruction** See [Figure: Needle bushing](#).

7. Press in the needle bushing 8x12x8 (1) to the limit stop with the installation tool (2) (part no. 676030) so the label on the needle bearing is facing outwards.
8. Allow the crankcase halves to cool in this position.

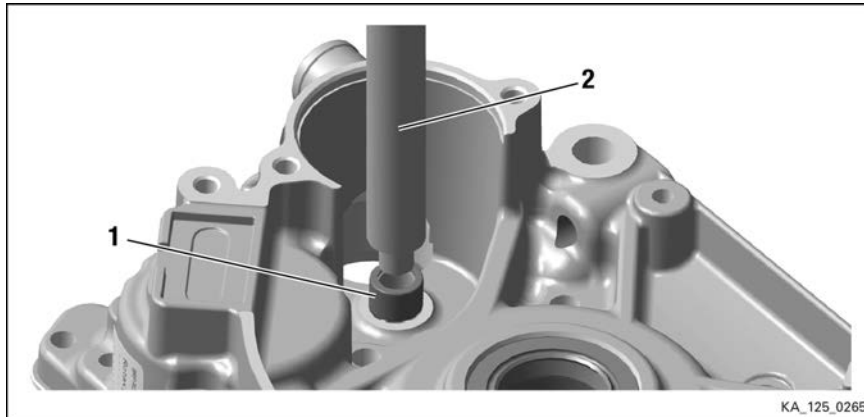

Figure 5.28: Needle bushing

1 Needle bushing 8x12x8

2 Installation tool (part no. 676030)

### INSTALLATION OF BALL BEARING AND OIL SEAL FOR CRANKCASE

#### **⚠ WARNING**

**Danger of severe burns and scalds!**  
Wear heat-resistant gloves during this process!

**Instruction** See Figure

1. Remove case half from the convection oven and drop onto a flat wood board with the case split pane.
2. Slide the ball bearing (1) of the balance shaft into the crankcase half to the limit stop so the closed side of the cage is facing the balance drive.
3. Install the thrust washer (2) and countersunk screw (3) with the phase of the lock washer pointing to the countersunk screw.
4. Coat the oil seal (4) for the ignition end crankcase half with oil in the area between the sealing lip and dust lip.
5. Press in the oil seal (4) to the limit stop with the insertion sleeve (5) (part no. 676010) so the open end of the oil seal for shaft is directed to the balance drive.

## BRP-Rotax REPAIR MANUAL

### NOTE

The oil seal for shaft can also be installed from outside to inside if the crankshaft is installed.

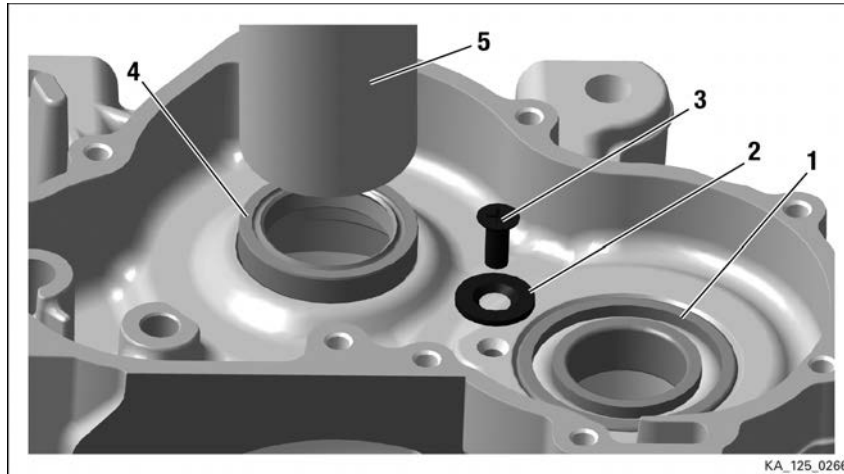

Figure 5.29: Ball bearing, oil seal

- |   |                                    |   |                     |
|---|------------------------------------|---|---------------------|
| 1 | Ball bearing 6005                  | 2 | Thrust washer       |
| 3 | Countersunk screw M5x12            | 4 | Oil seal AS 28x38x7 |
| 5 | Insertion sleeve (part no. 676010) |   |                     |

**Instruction** See [Figure: Insertion jig](#).

6. Rotate crankcase half.
7. Slide the ball bearing (1) of the crankshaft into the crankcase half to the limit stop so the closed side of the cage is facing to the crankshaft.
8. Grease the two oil seals for shaft (10x26x7) with MOLYCOTE 111 in the area of the sealing lip.
9. Press in the first oil seal for shaft to the limit stop with the Insertion jig (3) (part no. 676021) so the closed end of the oil seal (2) for shaft is visible.
10. Grease the installed oil seal for shaft with MOLYCOTE 111.
11. Press in the second oil seal for shaft to the limit stop with the installation tool (8) (part no. 676021) so the open end of the oil seal (4) for shaft is visible.
12. Allow the crankcase halves to cool in this position.

## BRP-Rotax REPAIR MANUAL

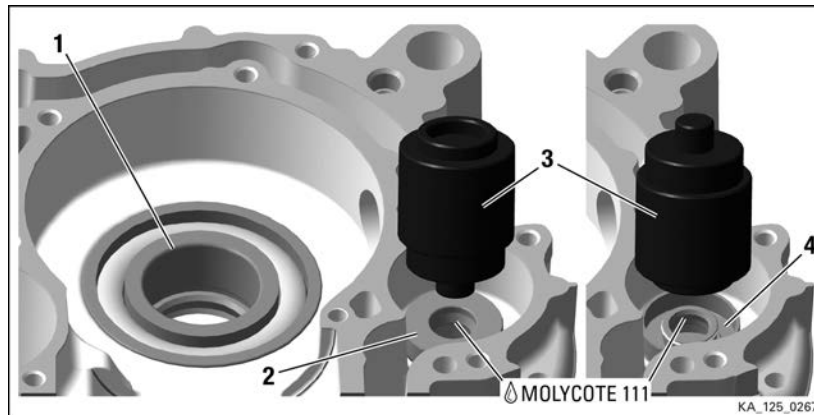

Figure 5.30: Insertion jig

1 *Ball bearing 6206*

2 *Oil seal 10x26x7*

3 *Insertion jig*

4 *Oil seal 10x26x7 (open end)*

# BRP-Rotax REPAIR MANUAL

## ASSEMBLY OF CRANKSHAFT, WATER PUMP SHAFT AND BALANCE SHAFT

**Special tools** The following special tools and equipment are required.

Part no.	Description	Field of application
n.a.	Convection oven	Case half
297434	LOCTITE Anti-Seize	Balance shaft, crankshaft

**Instruction** See [Figure: Crankshaft, Balancs shaft, Water pump shaft](#)

1. Coat main bearing seats of the crankshaft (1) with LOCTITE Anti-Seize.
2. Insert the crankshaft assy. (1) as shown on the picture into the crankcase half.
3. Coat bearing seats of the balance shaft (2) with LOCTITE Anti-Seize.
4. Insert the balance shaft (2) as shown on the picture into the crankcase half.
5. Insert the water pump shaft (3) as shown on the picture into the crankcase half.
6. Position new gasket (4) as shown on the picture into the crankcase half.

### NOTE

Adjustment of the clearance of the crankshaft is not required.

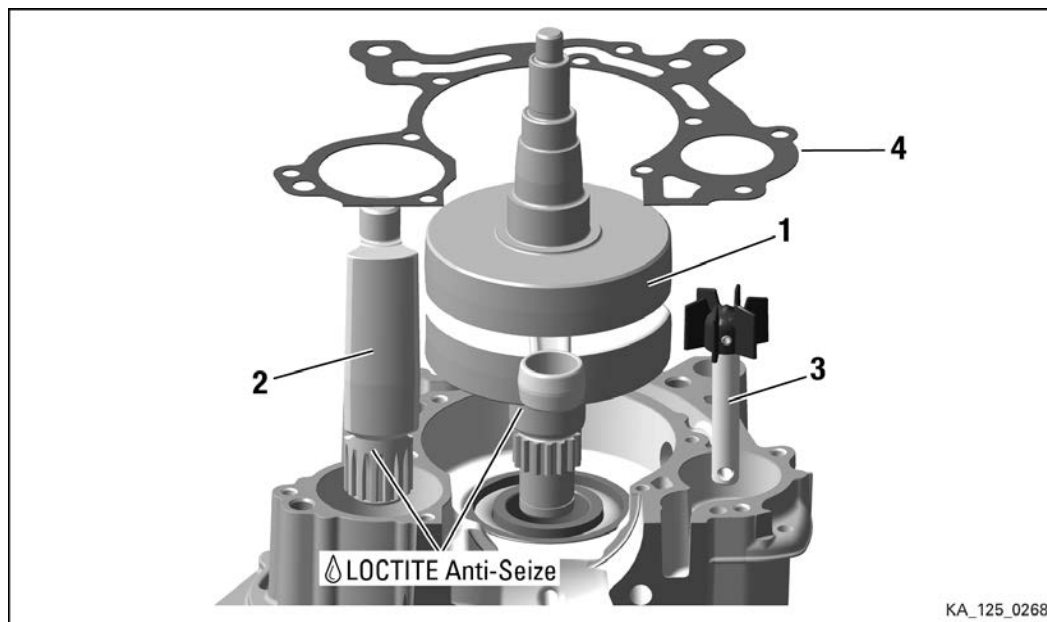

Figure 5.31: Crankshaft, Balance shaft, Water pump shaft

- |                    |                 |
|--------------------|-----------------|
| 1 Crankshaft assy. | 2 Balance shaft |
| 3 Water pump shaft | 4 Gasket        |

# BRP-Rotax REPAIR MANUAL

## ASSEMBLY OF THE CRANKCASE

### General

### NOTE

When using new studs for the assembly of the cylinder, first screw the long side of the threaded studs into the housing and secure them with LOCTITE 243.  
Tightening torque 10 Nm.

When using new housing halves insert new dowel pins!

### Instruction

#### ATTENTION

**Pay attention on the different lengths of the Allen. screws!**  
Tighten the Allen. screws crosswise, start in the middle of the housing.

1. Insert a new housing gasket part no. 650494 included in the gasket set part no. 296160.
2. Mount both housing halves together with 8 Allen screws M6x45 and 2 Allen screws M6x60 (see mounting plan) together.  
Tightening torque 10 Nm.
3. Let the Crankcase assy. cool down.
4. Attach the crankcase assy. on trestle mounting plate with 4 attachment screws.

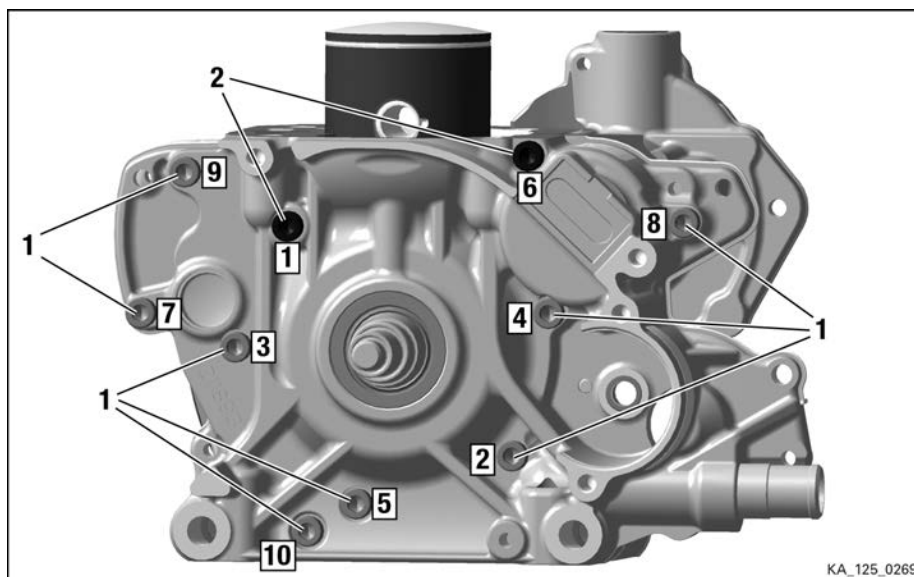

Figure 5.32: Mounting plan 1-10

1 Allen screw M6x45

2 Allen screw M6x60

5. Cut off the protruding section of the crankcase gasket with a sharp knife at the cylinder base surface.

## INSTALLATION OF CRANKCASE ASSY.

### Final tasks

1. Install cylinder assy. See Chapter 4).
2. Install balance drive and centrifugal clutch. See Chapter 7).
3. Take the engine off the assembly stand. See Chapter 3).
4. Install the engine in the kart chassis. See Chapter 3).
5. Filling the gear housing with oil. See Chapter 7).
6. Install the fuel line. See Chapter 3).
7. Install the exhaust system. See Chapter 9).
8. Install the carburetor and air filter. See Chapter 6).
9. Install the water pump hoses. See Chapter 8).
10. Install the ignition system. See Chapter 3).

### INSTALLATION OF BALANCE AND WATER-PUMP SHAFT DRIVE

**Instruction**            See [Figure: Crankcase.](#)

1. Insert the O-ring (1) in the crankshaft groove.
2. Rotate crankshaft to TDC.
3. Slide the balance gear (4) with hub collar outwards on the crankshaft until the markings (6) on the crankshaft and the balance gear match.
4. Slide the balance shaft gear (5) with hub collar inwards on the balance shaft until the markings (6) on the balance shaft and the balance gear match.

## BRP-Rotax REPAIR MANUAL

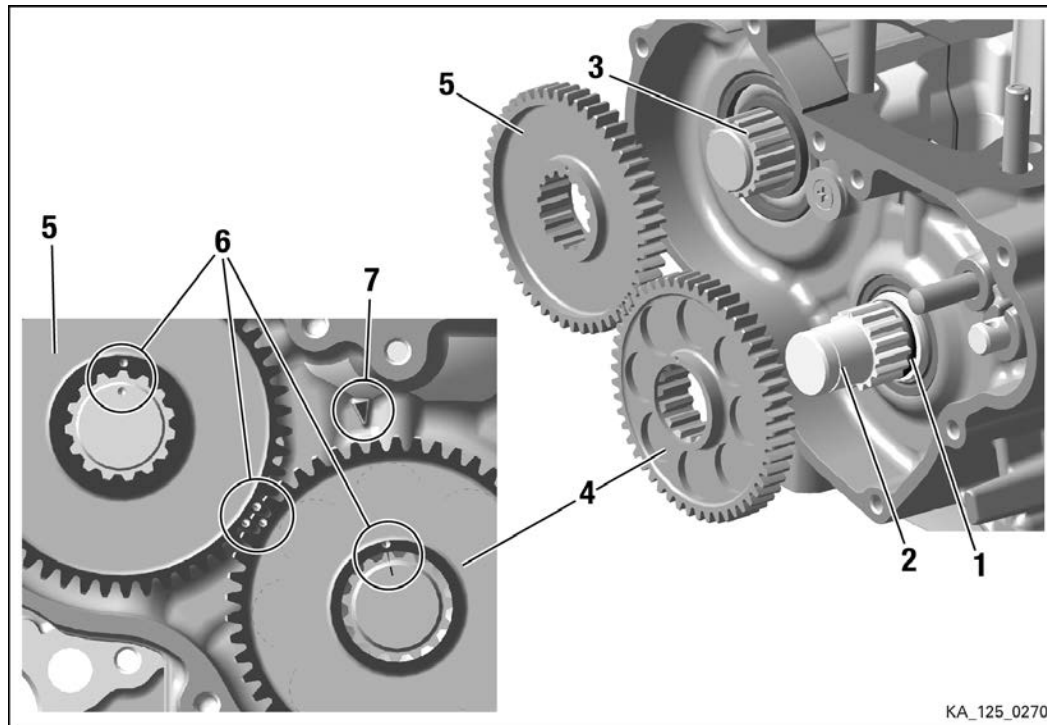

Figure 5.33: Crankcase

- |   |                      |   |                     |
|---|----------------------|---|---------------------|
| 1 | O-ring 18x3.5        | 2 | Crankshaft          |
| 3 | Balance shaft gear   | 4 | Balance gear        |
| 5 | Balance shaft gear   | 6 | Positioning marking |
| 7 | TDC position marking |   |                     |

### Instruction

See [Figure: Idle gear](#).

5. Slide the water pump gear (1) onto the crankshaft.

#### ATTENTION

**Do not bend the Retaining ring during installation.**  
Install a new Retaining ring on the balance shaft and crankshaft

6. Check that the retaining ring (2) is correctly seated in the grooves of the balance shaft and crankshaft.
7. Install the thrust washer (3), needle pin (4) and water pump pinion (5) on the water-pump shaft.
8. Check the seating of the needle pin (4) in the cutout in the water pump pinion.
9. Install the idle gear (7) on the cylindrical pin in the case.

## BRP-Rotax REPAIR MANUAL

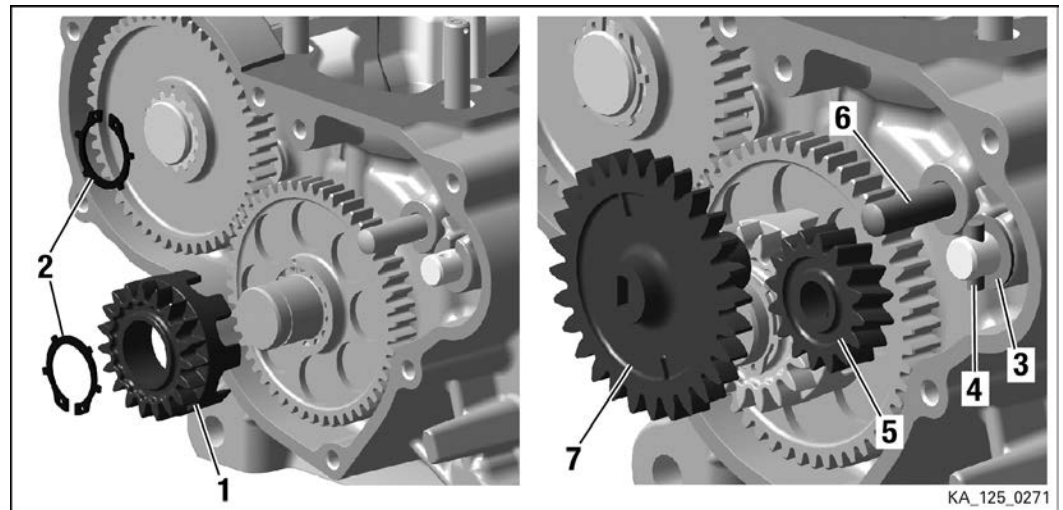

Figure 5.34: Idle gear

- |   |                         |   |                                |
|---|-------------------------|---|--------------------------------|
| 1 | Water pump gear 19 T    | 2 | Retaining ring with lug 20x1.2 |
| 3 | Thrust washer 10.1/17/1 | 4 | Needle pin 4x15.8              |
| 5 | Water pump pinion 16 T  | 6 | Locating pin 8 small M6x40     |
| 7 | Idle gear 28/13 T       |   |                                |

10. Position new gasket (1) on the case.

11. Screw on gear cover (2) with 6 Allen screws M6x25 (4) with sealing ring A 6x10 (3) and 2 Allen screws M6x30 (5). Tightening torque 10 Nm (90 in. lb).

### NOTE

Use sealing ring A6x10 to seal the oil drainage plug and oil level plug.

**BRP-Rotax**  
**REPAIR MANUAL**

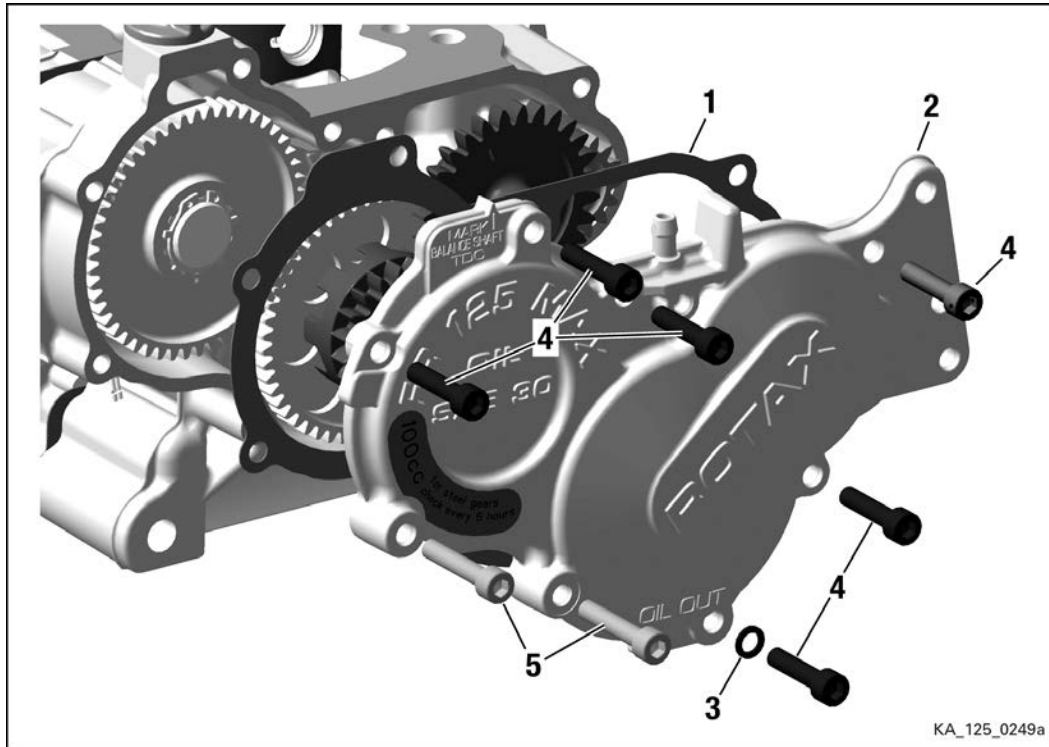

Figure 5.35

- |                       |                     |
|-----------------------|---------------------|
| 1 Gasket              | 2 Gearbox cover     |
| 3 Sealing ring A 6x10 | 4 Allen screw M6x25 |
| 5 Allen screw M6x30   |                     |

**Chapter: Chapter 6**  
**CARBURETOR AND INTAKE SILENCER**

**TOPICS IN THIS CHAPTER**

<b>System description .....</b>	<b>2</b>
<b>Removal of the carburetor and intake silencer .....</b>	<b>3</b>
Removal of the carburetor and intake silencer .....	3
Removal of the fuel pump.....	4
Disassembly of the carburetor .....	5
Disassembly of the intake silencer .....	7
<b>Carburetor and intake silencer – inspection of components .....</b>	<b>8</b>
Inspection of the carburetor .....	8
Inspection of the fuel pump .....	9
Inspection of the intake silencer.....	9
<b>Installing the carburetor and intake silencer.....</b>	<b>11</b>
Assembly of carburetor .....	11
Assembly of float housing .....	11
Assembly of intake silencer .....	12
<b>Installation of fuel pump, carburetor .....</b>	<b>13</b>

**Contents**

This chapter describes the removal and installation of the carburetor and intake silencer assembly for the ROTAX® 125 MAX evo (incl. Junior-, Mini-, Micro MAX evo) engine. The description is divided into subsections.

**BRP-Rotax**  
**REPAIR MANUAL**

**SYSTEM DESCRIPTION**

**Overview**

Position on engine

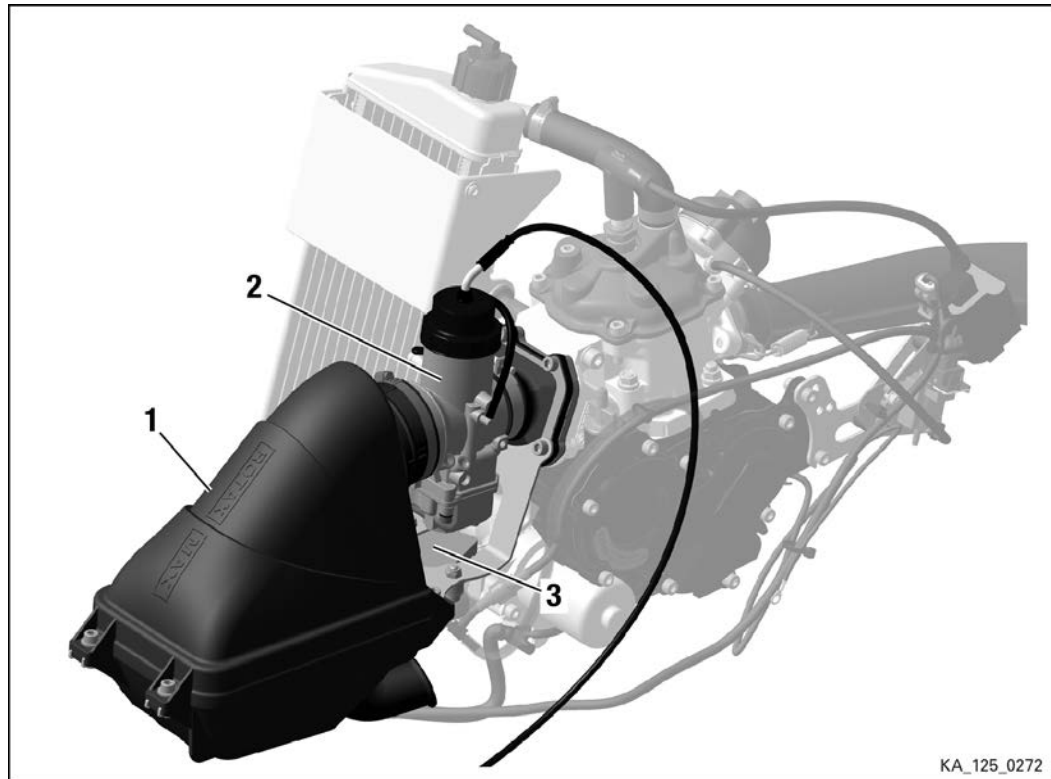

Figure 6.1: Position on engine, TYPICAL (Figure shows 125 MAX evo engine)

1 Intake silencer

2 Carburetor

3 Fuel pump

## REMOVAL OF THE CARBURETOR AND INTAKE SILENCER

### Safety instructions

#### **⚠ WARNING**

##### **Danger of explosion and ignition!**

Overflowing and spoilt gasoline must be absorbed immediately with a binding agent and correctly disposed. Do not work with open flames and sources of ignition. Fuel must not come into contact with hot parts such as engine or exhaust since this may cause a fire!.

### Preparation

The following preparations should be carried out before removing the components: See [Figure: Carburetor and intake silencer](#).

1. Pull off fuel pipe between the fuel tank and fuel pump from the fuel pump (4) and seal it with a screw.
2. Remove the Bowden cable. See also Chapter 3).

## REMOVAL OF THE CARBURETOR AND INTAKE SILENCER

### Instruction

See [Figure: Carburetor and intake silencer](#).

#### **ATTENTION**

**Fuel may spill out when removing the carburetor.**

#### **ENVIRONMENTAL NOTE**

##### **Protect the environment!**

Use a container to collect the fuel from the carburetor.

To remove the carburetor and intake silencer the following steps are required:

1. Remove the fuel line (1) between the fuel pump (4) and the carburetor.
2. Remove the impulse line (2).
3. Loosen the hose clamp (7).
4. Loosen 3 Allen screws (5) and remove the carburetor (3) along with the intake silencer (8), support bracket (6) and fuel pump (4).

## BRP-Rotax REPAIR MANUAL

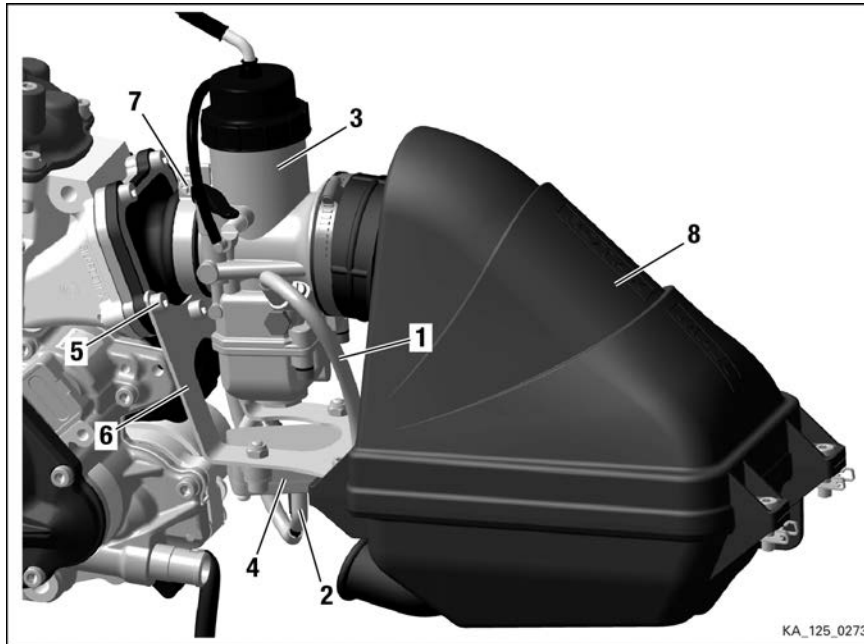

Figure 6.2: Carburetor and intake silencer

- |                               |                   |
|-------------------------------|-------------------|
| 1 Fuel line to the carburetor | 2 Impulse line    |
| 3 Carburetor                  | 4 Fuel pump       |
| 5 Allen screw M6x25           | 6 Support bracket |
| 7 Pipe clamp 51               | 8 Intake silencer |

### REMOVAL OF THE FUEL PUMP

**Instruction** See [Figure: Fuel pump](#).

To remove the fuel pump the following steps are required:

1. Loosen 2 Allen screws M6 with washers fixed by lock nuts.
2. Remove the fuel pump (1) from the support bracket (2).

## BRP-Rotax REPAIR MANUAL

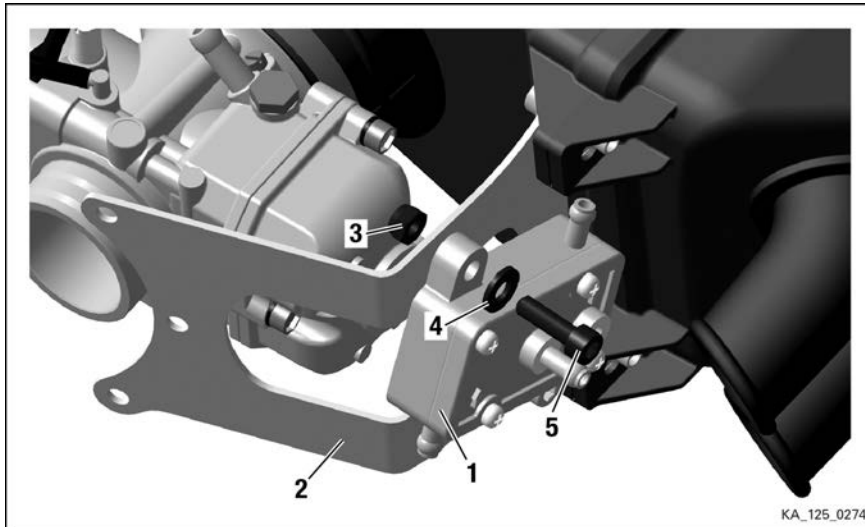

Figure 6.3: Fuel pump

- |                     |                   |
|---------------------|-------------------|
| 1 Fuel pump         | 2 Support bracket |
| 3 Lock nut M6       | 4 Washer 6.4      |
| 5 Allen screw M6x20 |                   |

### DISASSEMBLY OF THE CARBURETOR

1. Disassembly of the carburetor to the parts shown in [Figure: Carburetor](#) and clean them with fuel.

**BRP-Rotax**  
**REPAIR MANUAL**

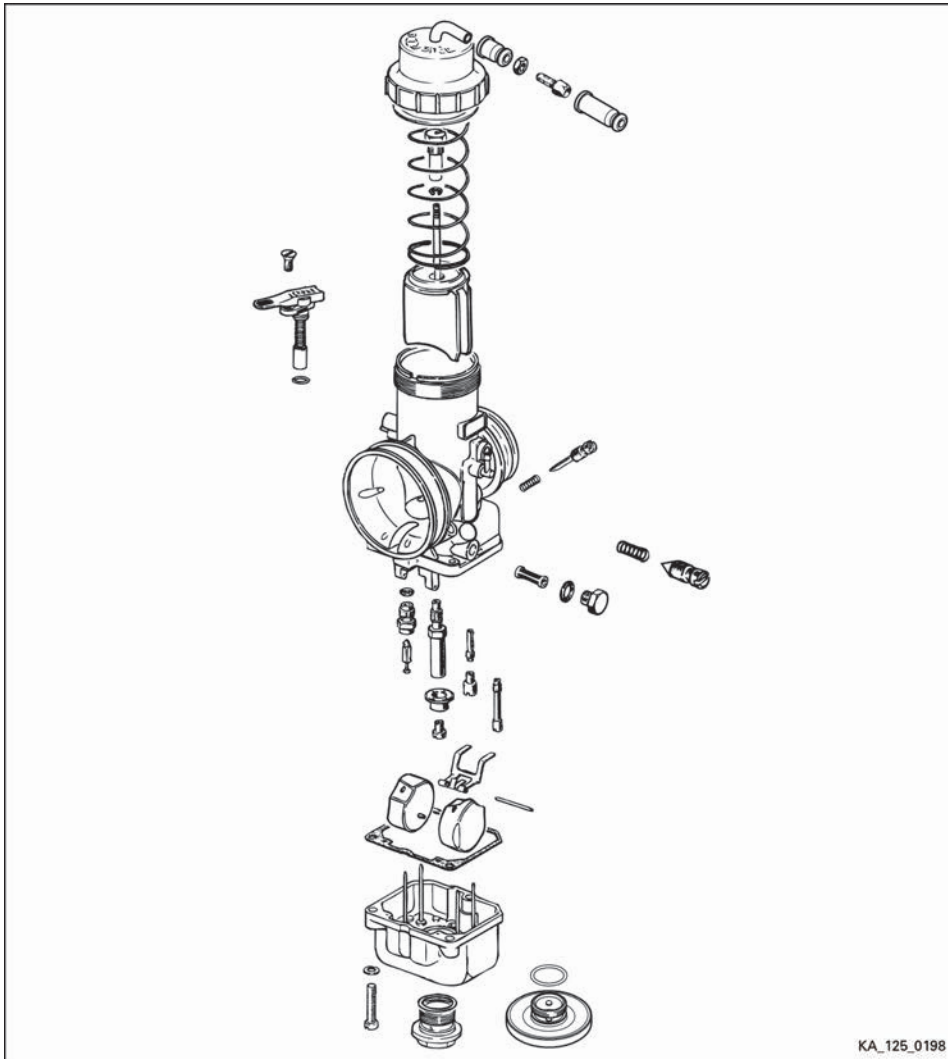

Figure 6.4: Carburetor

# BRP-Rotax REPAIR MANUAL

## DISASSEMBLY OF THE INTAKE SILENCER

Intake silencer See [Figure: Intake silencer](#).

1. Disassemble the intake silencer to the parts shown in following Figure.

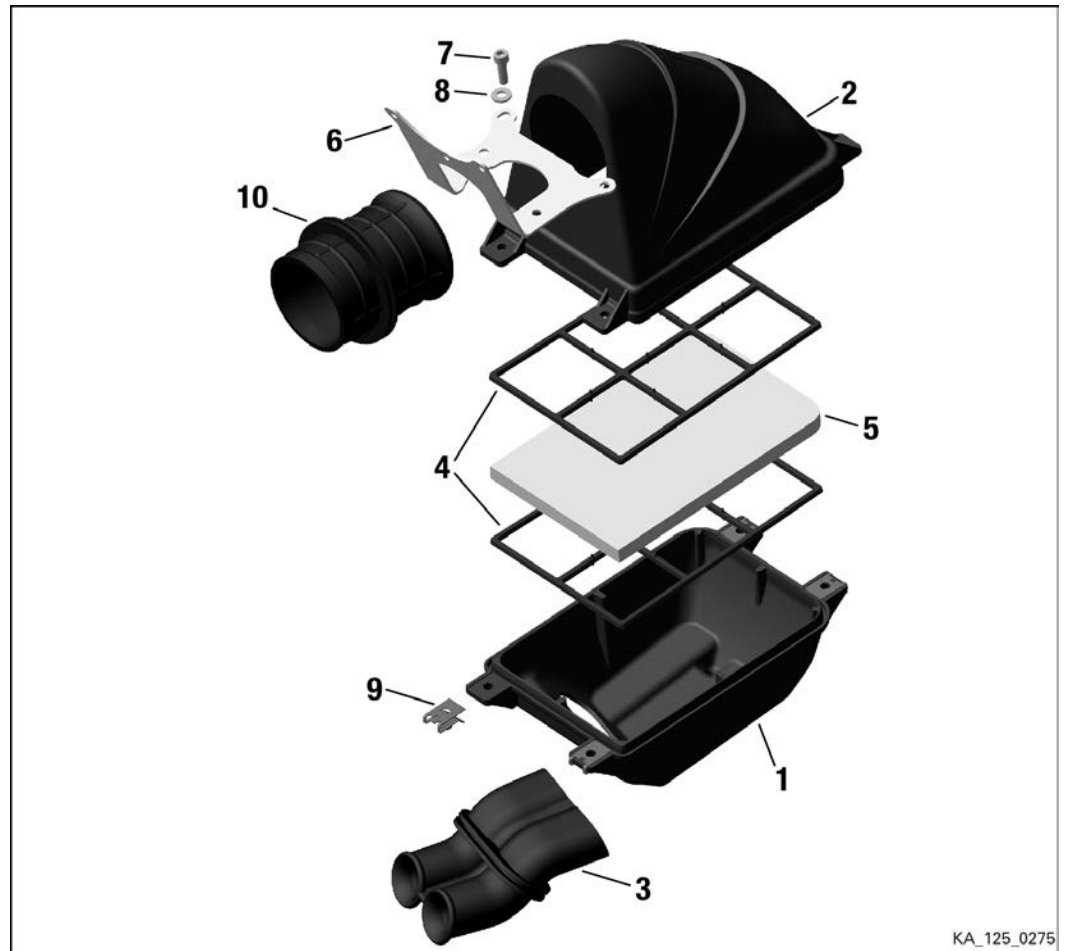

Figure 6.5: Intake silencer

- |                        |                                 |
|------------------------|---------------------------------|
| 1 Intake silencer case | 2 Intake silencer cover         |
| 3 Intake silencer tube | 4 Filter element support/holder |
| 5 Filter element       | 6 Support bracket               |
| 7 Washer 6.4           | 8 Allen screw M6x20             |
| 9 Nut M6               |                                 |

**BRP-Rotax**  
**REPAIR MANUAL**

**CARBURETOR AND INTAKE SILENCER – INSPECTION OF COMPONENTS**

In the case of problems with the fuel supply the carburetor should be checked:  
First the components should be cleaned and then inspected.

**INSPECTION OF THE CARBURETOR**

**Instruction**      See [Figure: Carburetor](#).

1. Clean the fuel filter (1) and make sure that it is in good condition.
2. Blow compressed air through the holes in the carburetor housing (2) and the jets (3, 4, 5, 6 and 7) and make sure that there is no pollution to have an easy and free flow.
3. Check that the clip (8) is tightly seated on the jet needle (9).

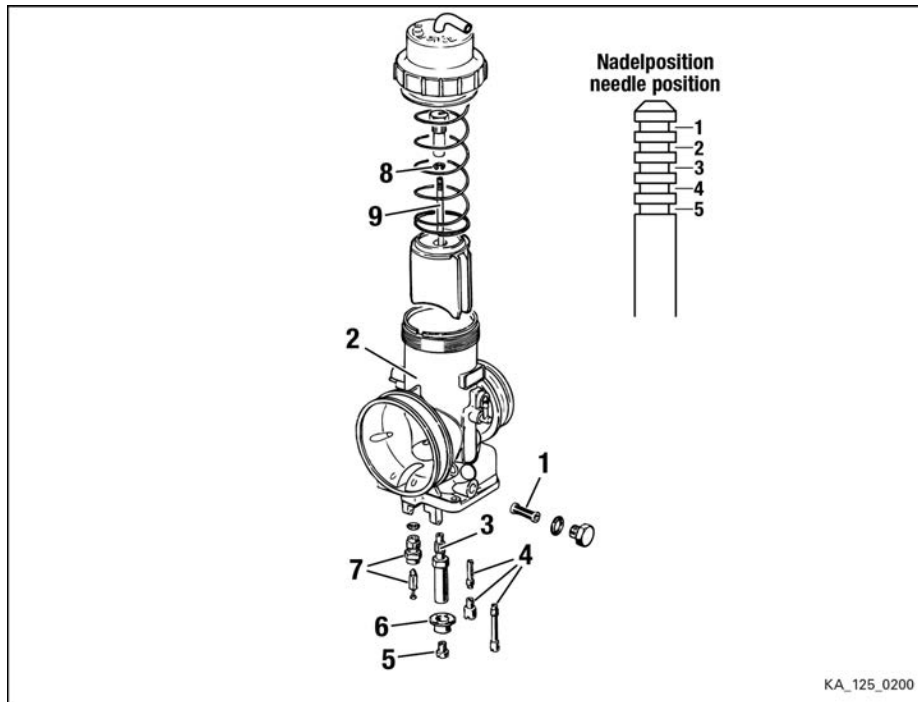

Figure 6.6: Carburetor

- |  |                           |
|--|---------------------------|
| 1 Fuel filter                                | 2 Carburetor housing      |
| 3 Needle jet DP 267                          | 4 Idling and starter jets |
| 5 Main jet                                   | 6 Main jet cup            |
| 7 Needle valve 150 (standard) 200 (optional) | 8 Clip                    |
| 9 Jet needle K 57                            |                           |

# BRP-Rotax REPAIR MANUAL

## INSPECTION OF THE FUEL PUMP

### General

### NOTE

*Only the complete membrane and gasket set of the fuel pump can be replaced.*

Fuel pump gasket set: Part no. 296165

### Instruction

See [Figure: Fuel pump](#).

1. Check the condition of the impulse pipe (1), fuel line (2) and fuel overflow line (3) and in case of doubt replace them.

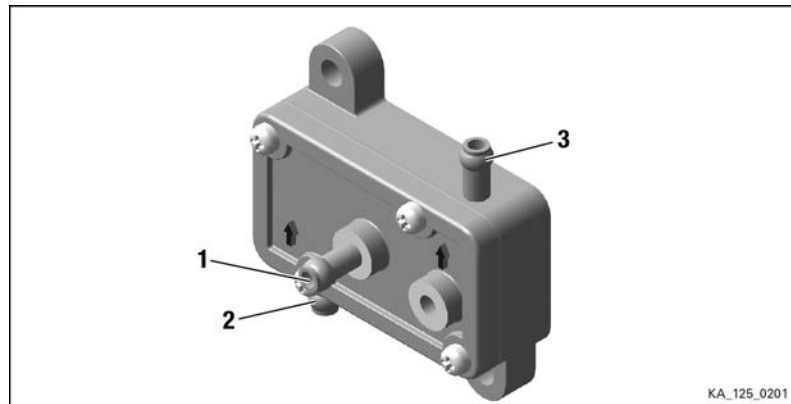

Figure 6.7: Fuel pump

1 Impulse pipe

2 Fuel line (from fuel tank)

3 Fuel line (to carburetor)

## INSPECTION OF THE INTAKE SILENCER

### General

### ATTENTION

**A damaged filter element must be replaced immediately. Otherwise dirt particles can enter the intake and cause damage to the engine.**

### Instruction

See [Figure: Intake silencer](#).

1. Inspect the silencer case (1) and silencer cover (2) for cracks.
2. Inspect the intake silencer tube (3) and carburetor socket (10) for cracks or porosity.
3. Clean the filter element (5) with filter cleaner and oil it afterwards slightly with air filter oil.
4. Inspect the filter element (5) and filter element holders (4) for cracks.

**BRP-Rotax**  
**REPAIR MANUAL**

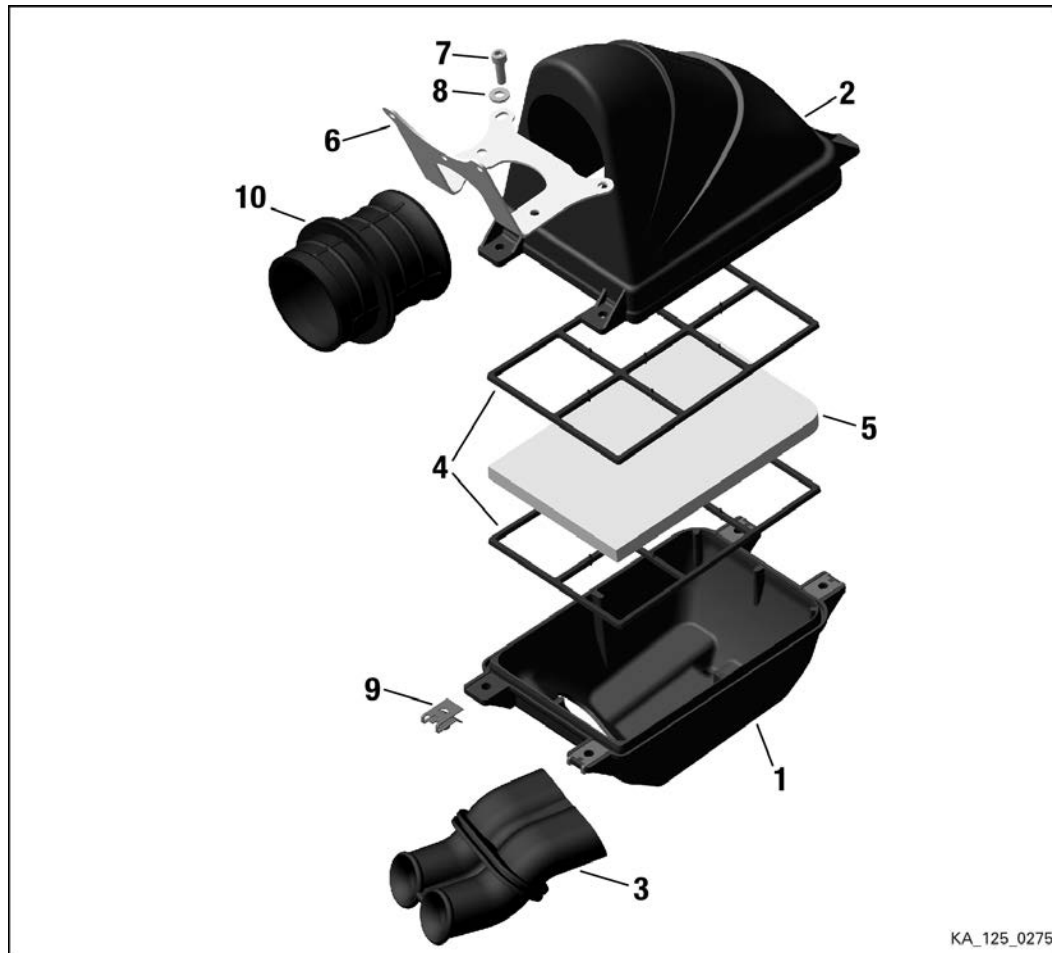

KA\_125\_0275

Figure 6.8: Intake silencer

- |   |                      |   |                               |
|---|----------------------|---|-------------------------------|
| 1 | Intake silencer case | 2 | Intake silencer cover         |
| 3 | Intake silencer tube | 4 | Filter element support/holder |
| 5 | Filter element       | 6 | Support bracket               |
| 7 | Washer 6.4           | 8 | Allen screw M6x20             |
| 9 | Nut M6               |   |                               |

## INSTALLING THE CARBURETOR AND INTAKE SILENCER

### ASSEMBLY OF CARBURETOR

**Instruction**            **NOTE**

*Use ROTAX® gasket set, part no. 293834.*

1. Assemble the components in the opposite succession as you disassembled them. See also Chapter 6) section: Disassembly of the carburetor.

### ASSEMBLY OF FLOAT HOUSING

**General**                **NOTE**

*The tips of the bracket must be at the same height. Adjust them if necessary. In this check the float chamber should not have been fitted.*

**Instruction**            The following steps are required to install the float housing:

See [Figure: Float chamber](#)

1. Check the position of the float attachment (1) in its installed state.
2. When the floats (2) are inserted you should be able to see the word "ALTO" on their top surfaces.
3. Install and adjust the Bowden cable in accordance with the operating instructions.
4. Set the idle adjuster screw (3) and adjustment screw kit (4).

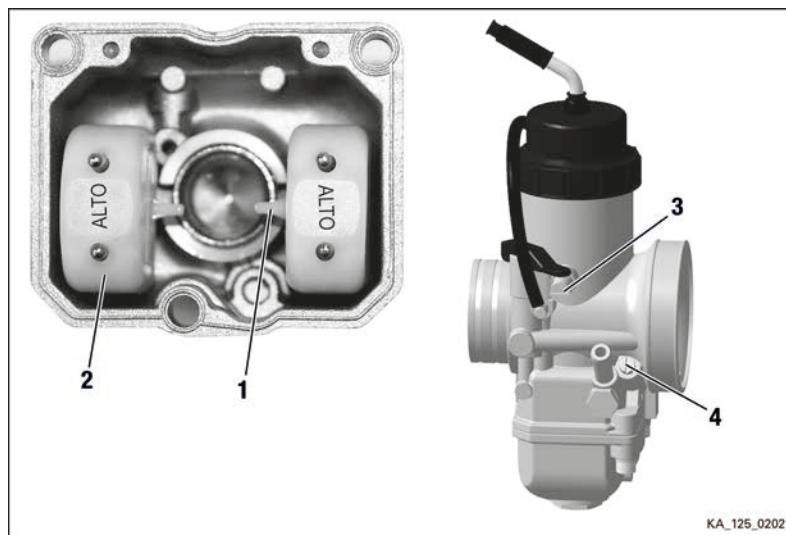

Figure 6.9: Float chamber

1 *Float attachment*

2 *Float 4.0*

3 *Adjustment screw*

4 *Adjustment screw kit*

# BRP-Rotax REPAIR MANUAL

## ASSEMBLY OF INTAKE SILENCER

### General

### NOTE

*Before assembly, first immerse the filter element in filter oil. Squeeze out excess oil.*

### Instruction

The following steps are required to install the intake silencer:

1. Assemble the components in the opposite succession as you disassembled them. See also Chapter 6. section: Disassembly of the intake silencer.

## INSTALLATION OF FUEL PUMP, CARBURETOR

### Safety instructions

**⚠ WARNING**

**Danger of explosion and ignition!**

Overflowing and spoilt gasoline must be absorbed immediately with a binding agent and correctly disposed. Do not work with open flames and sources of ignition. Fuel must not come into contact with hot parts such as engine or exhaust since this may cause a fire!.

### NOTE

*When assembling the parts make sure that the pipes are connected to the correct terminal!*

**Preparation** The following preparations should be carried out before installing the components:

#### Installation of fuel pump

→ Install the fuel pump with two M6x20 cylinder screws and new locknuts with washers onto the support bracket. Tightening torque 10Nm (89 in. lb)

→ Install support bracket with fuel pump onto the carburetor flange using 3 Allen screws M6x25. Tightening torque 7 Nm (62 in. lb).

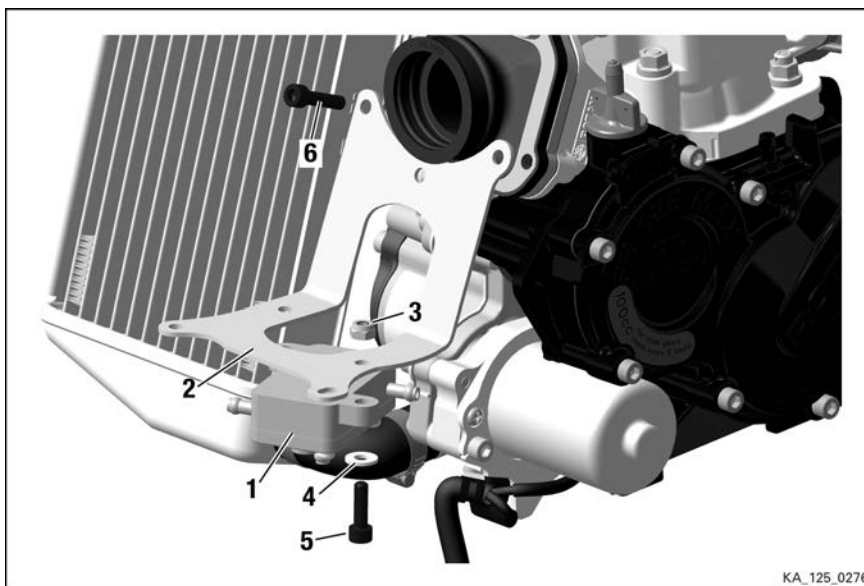

Figure 6.10: Fuel pump

- |                     |                     |
|---------------------|---------------------|
| 1 Fuel pump         | 2 Support bracket   |
| 3 Lock nut M6       | 4 Washer 6.4        |
| 5 Allen screw M6x20 | 6 Allen screw M6x25 |

## BRP-Rotax REPAIR MANUAL

### Instruction

To install the carburetor and intake silencer the following steps are required:

See [Figure: Carburetor and intake silencer](#).

1. Pull the hose clamp (3) over the carburetor flange.
2. Push the carburetor (1) onto the carburetor flange (2) and fasten the hose clamp (3).
3. Secure the intake silencer (4) with the hose clamp (5) on the carburetor.
4. Secure the intake silencer on the support bracket (6).
5. Check the Bowden cable (11) for wear, especially where it bends. Bends can cause the throttle to be stuck in fully open. See Chapter 9.
6. Connect the fuel feed line (9) and Bowden cable (11) to the carburetor.
7. Connect the impulse pipe (10).

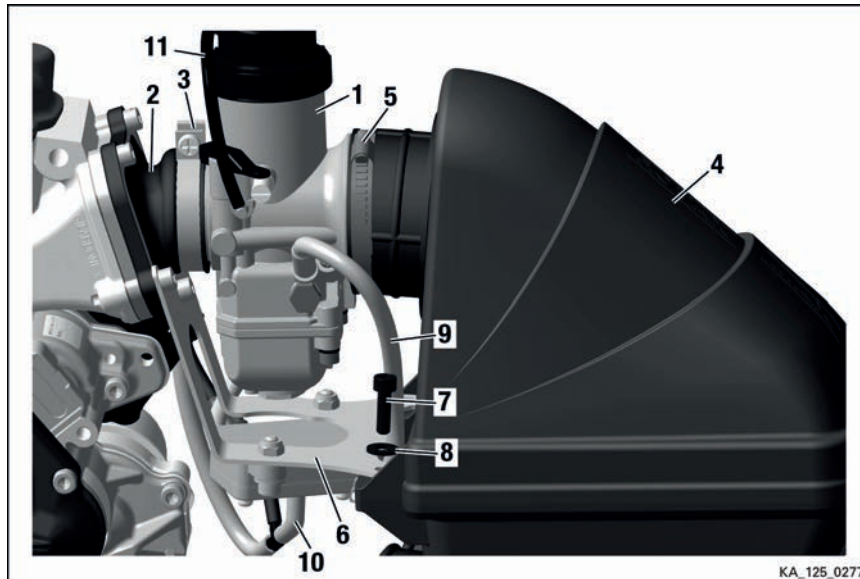

Figure 6.11: Carburetor and intake silencer

- |  |                     |
|--|---------------------|
| 1 Carburetor                                   | 2 Carburetor flange |
| 3 Hose clamp                                   | 4 Intake silencer   |
| 5 Hose clamp 51                                | 6 Support bracket   |
| 7 Allen screw M6x25                            | 8 Washer 6.4        |
| 9 Fuel feed tube/line                          | 10 Impulse pipe     |
| 11 Bowden cable (loosely, not mounted in fig.) |                     |

**Chapter: Chapter 7**  
**CENTRIFUGAL CLUTCH, PRIMARY AND BALANCE DRIVE**

**TOPICS IN THIS CHAPTER**

<b>System description .....</b>	<b>2</b>
<b>Removal of the clutch and starter gear assy. ....</b>	<b>4</b>
Removal of the centrifugal clutch assy. ....	4
Removal of the electric starter .....	4
Removal of the clutch drum .....	5
Removal of the sprocket .....	7
Removal of the starter gear assy. ....	8
<b>Inspection of clutch and starter gear assy. ....</b>	<b>11</b>
Inspection of the clutch drum .....	11
Inspection of the needle cage and sprocket .....	11
Inspection of the starter reduction gear assy. ....	11
Inspection of the electric starter .....	12
Inspection of the clutch and starter gear assy. ....	13
Electric starter repair kit .....	14
Disassembling of electric starter .....	14
Assembling of electric starter .....	15
<b>Installation of clutch and starter gear assy. ....</b>	<b>17</b>
Installation of the starter reduction gear assy. ....	17
Installation of the starter gear assy. ....	17
Assembly of the clutch drum .....	19
Installation of the sprocket .....	19
Installation of bearing sleeve (for sprockets with 11 teeth only) .....	20
Installation of the clutch drum .....	21
Installation of the electric starter .....	23
<b>Filling gearbox with oil .....</b>	<b>25</b>

**Contents**            This chapter describes the disassembly and assembly of the centrifugal clutch and the primary and balance drive for the ROTAX® 125 MAX evo (incl. Junior-, Mini-, Micro MAX evo) engine. The description is broken down into subsections.

## SYSTEM DESCRIPTION

### Overview

Position on engine

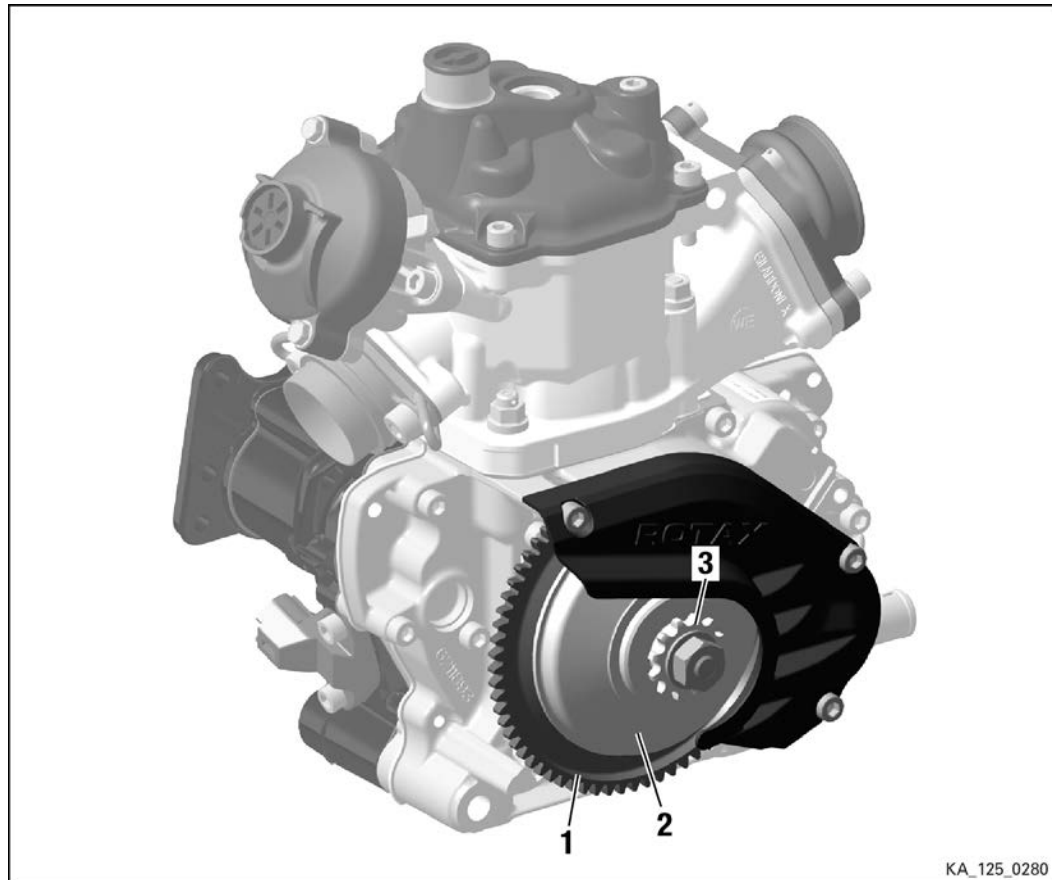

Figure 7.1: Clutch and starter gear assy.

1 Starter gear assy.

2 Clutch drum

3 Sprocket

# BRP-Rotax REPAIR MANUAL

## Overview

## Components of clutch and starter assy.

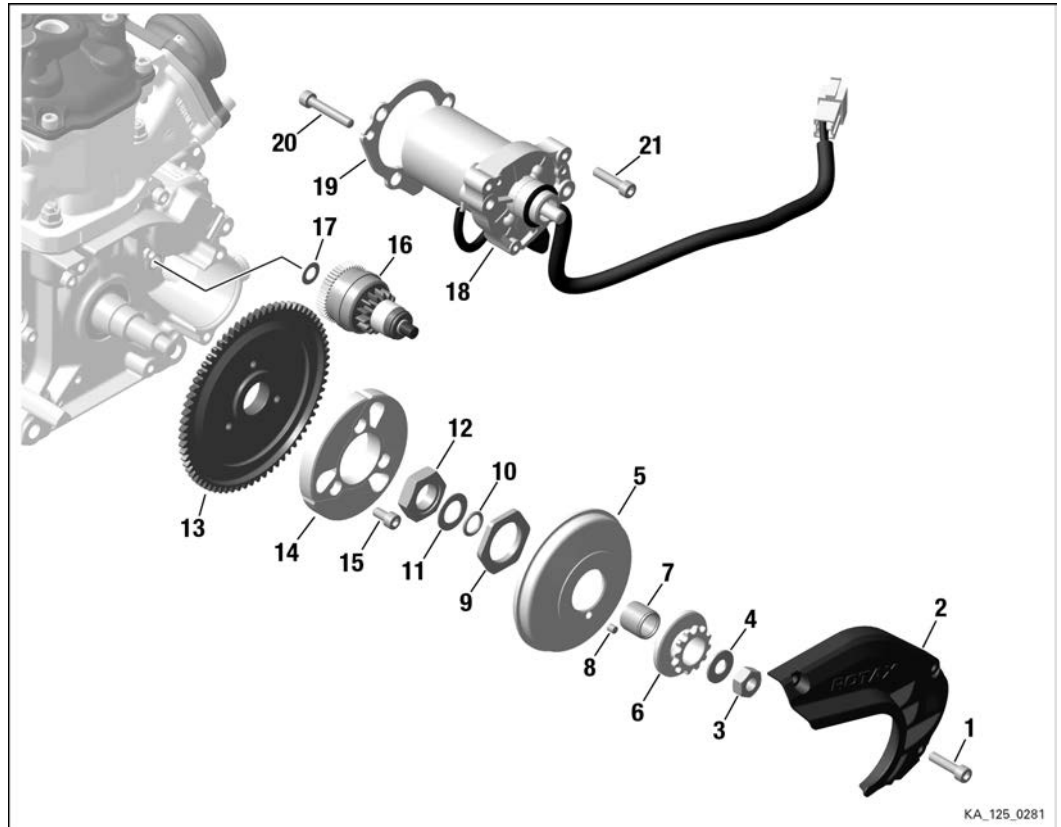

Figure 7.2

- |  |                                 |
|--|---------------------------------|
| 1 Allen screw M6x25  | 2 Chain protection              |
| 3 Hex. nut M10x1   | 4 Thrust washer                 |
| 5 Clutch drum  | 6 Sprocket                      |
| 7 Plain bearing (11T sprockets) or needle cage (all other sprockets) | 8 Needle pin 5x5                |
| 9 Hex. nut 28x1  | 10 O-ring                       |
| 11 Thrust washer 15.2  | 12 Hex. nut M20x1.5             |
| 13 Starter gear  | 14 Clutch                       |
| 15 Allen screw M6x12   | 16 Starter reduction gear assy. |
| 17 Thrust washer 8.5   | 18 Electric starter             |
| 19 Starter support   | 20 Allen screw M6x35            |

## REMOVAL OF THE CLUTCH AND STARTER GEAR ASSY.

### REMOVAL OF THE CENTRIFUGAL CLUTCH ASSY.

#### Safety instructions

**⚠ WARNING**

Danger of severe burns and scalds! Always allow the engine to cool down to ambient temperature before starting any work.

**⚠ WARNING**

**Danger of explosion and ignition!**  
Overflowing and split gasoline must be absorbed immediately with a binding agent and correctly disposed of. Do not work with open flames and sources of ignition. Fuel must not be allowed to come into contact with hot engine parts and components.



### REMOVAL OF THE ELECTRIC STARTER

**Instruction** See [Figure: Electric starter](#)

1. Disconnect electrical connection from the starter.
2. Remove the electric starter (1) completely by unscrewing 2 Allen screws M6x35 (3) from the crankcase and gearbox case.

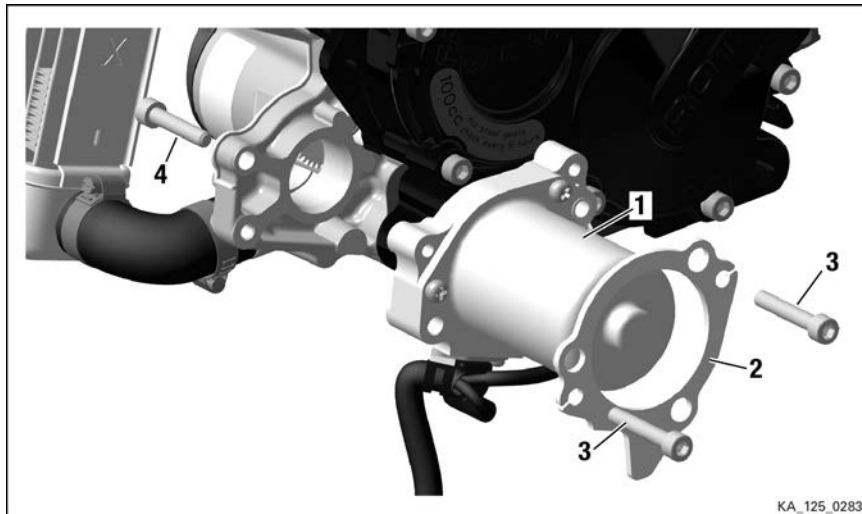

Figure 7.3: Electric starter

1 Electric starter

2 Starter support

3 Allen screw M6x35

4 Allen screw M6x30

# BRP-Rotax REPAIR MANUAL



## REMOVAL OF THE CLUTCH DRUM

### Special tools

The following special tools and equipment are required:

Part no.	Description	Use
277381	Locking tool	Spark plug thread
676205	Fixation tool assy.	Starter gear assy.

### Preparation

- Remove the chain protection (1).

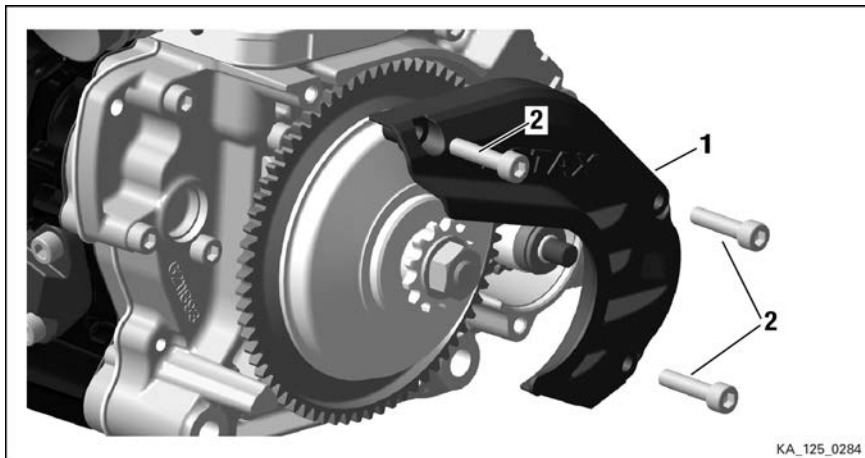

Figure 7.4: Cover

1 Chain protection

2 Allen screw M6x25

### Instructions

1. Remove the spark plug.
2. Preferred method 1: screw in fixation tool for crankshaft (1) into the spark plug hole to the limit stop.
3. Method 2: insert fixation tool assembly (2) (part no. 676205) in the starter gear assembly.

# BRP-Rotax REPAIR MANUAL

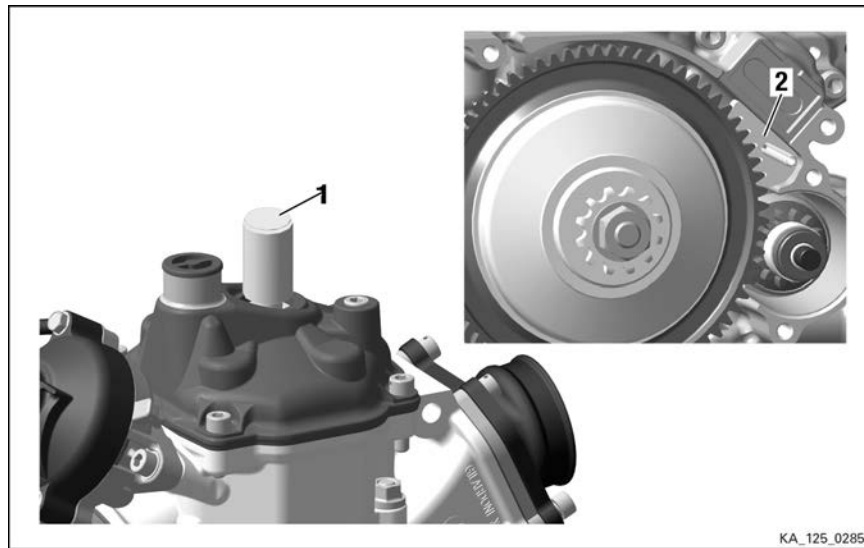

Figure 7.5

1 Fixation tool for crankshaft

2 Fixation tool assy.

4. Unscrew and remove hex nut (1).
5. Remove thrust washer (2), clutch drum with sprocket (3), needle cage (4) O-ring (5) and thrust washer 15.2 (6).

## NOTE

*With the sprocket with 11 teeth a plain bearing is used instead of the needle cage (4). It is pressed into the sprocket.*

## BRP-Rotax REPAIR MANUAL

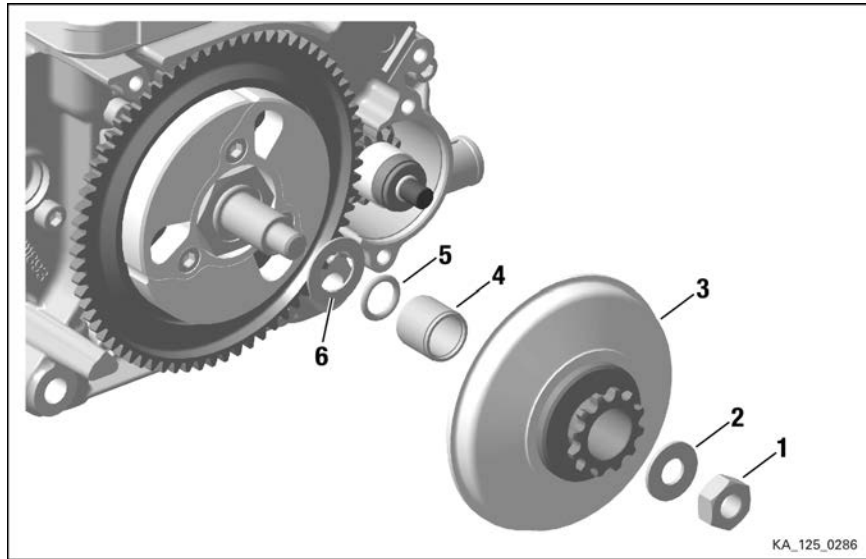

Figure 7.6

- |                  |                               |
|------------------|-------------------------------|
| 1 Hex. nut M10x1 | 2 Thrust washer               |
| 3 Clutch drum    | 4 Needle cage / Plain bearing |
| 5 O-ring         | 6 Thrust washer 15.2          |



---

### REMOVAL OF THE SPROCKET

**Instruction** See [Figure: Fixation tool](#)

1. Fix fixation tool for sprocket (1) in a vise.
2. Insert clutch drum (4) with installed sprocket (2) into the corresponding toothed cutout.
3. Unscrew the hex nut (5) for the sprocket.
4. Remove the sprocket from the clutch drum.

## BRP-Rotax REPAIR MANUAL

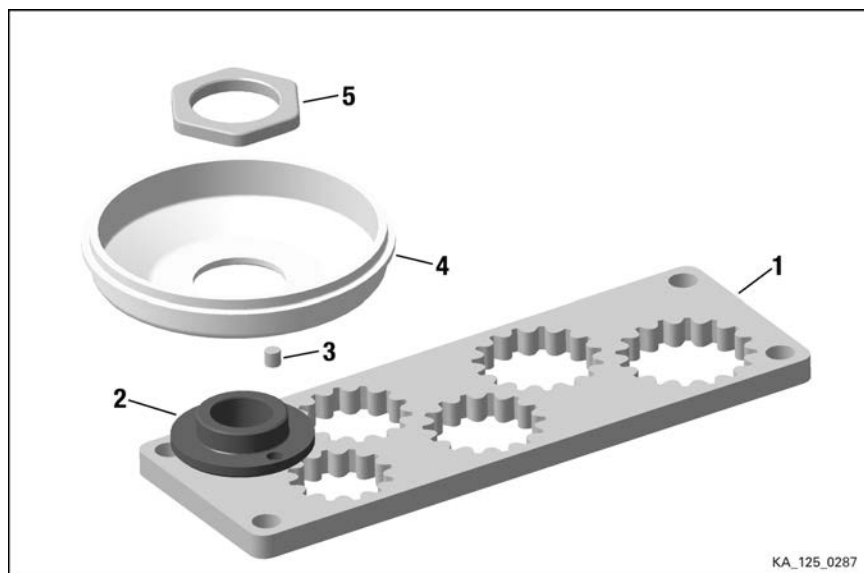

Figure 7.7: Fixation tool

- |                  |               |
|------------------|---------------|
| 1 Fixation tool  | 2 Sprocket    |
| 3 Needle pin 5x5 | 4 Clutch drum |
| 5 Hex. nut       |               |



### REMOVAL OF THE STARTER GEAR ASSY.

#### Special tools

The following special tools and equipment are required:

Part no.	Description	Field of application
276016	Puller assy.	Starter gear assy.
277381	Fixation tool	Spark plug thread
676205	Fixation tool assy.	Starter gear assy.

#### Instructions

Proceed as follows to remove the starter gear assy.:

1. Method 1: screw in fixation tool for crankshaft (1) into the spark plug thread to the limit stop.
2. Method 2: insert fixation tool assy. (2) (part no. 676205) in the starter gear assy.

# BRP-Rotax REPAIR MANUAL

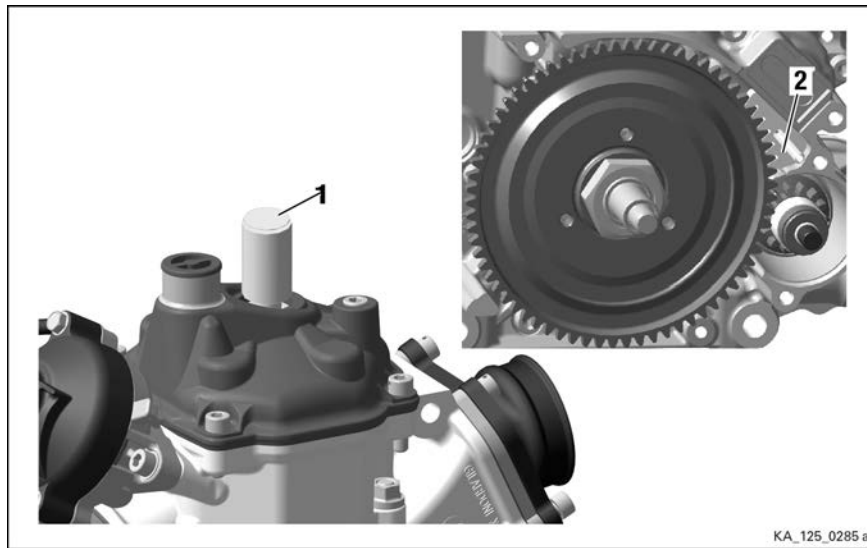

Figure 7.8: Fixation tool

1 Fixation tool (crankshaft)

2 Fixation tool (starter gear)

3. Remove the clutch (3).
4. Unscrew hex. nut M20 (4).

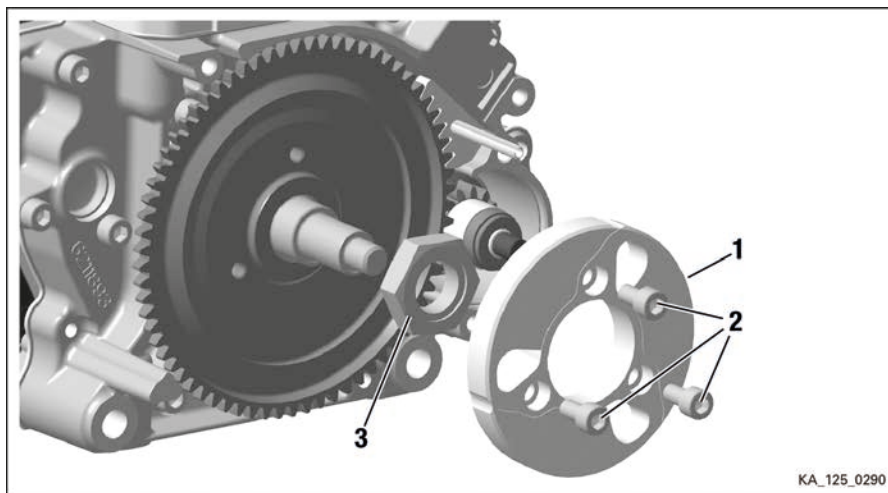

Figure 7.9: Clutch

1 Clutch

2 Allen screw M6x12

3 Hex. nut M28x1

## BRP-Rotax REPAIR MANUAL

5. Fasten the puller assy. (1) to the starter gear assembly with 3 Allen screws M6x60 (2).

### NOTE

Make sure the screws do not touch the housing. Do not screw them in too far.

6. Pull out starter gear assy. (3).
7. Remove starter reduction gear assy. (4) with the thrust washer (5) below.

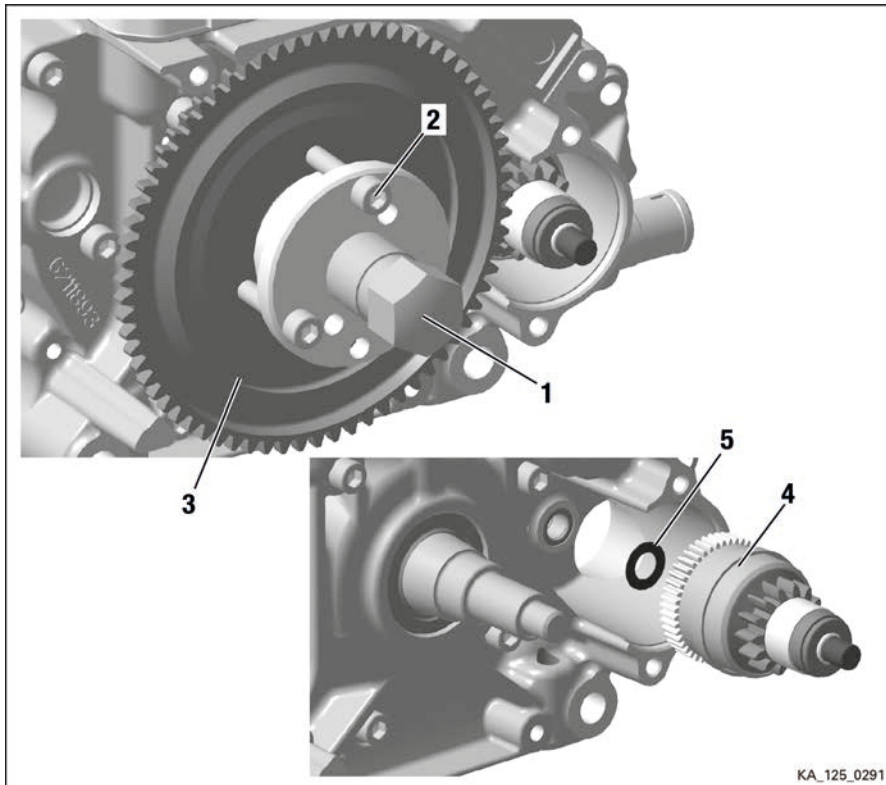

Figure 7.10: Starter gear assy.

- |                      |                          |
|----------------------|--------------------------|
| 1 Puller assy.       | 2 Allen screws M6x60     |
| 3 Starter gear assy. | 4 Starter reduction gear |
| 5 Thrust washer      |                          |



## INSPECTION OF CLUTCH AND STARTER GEAR ASSY.

### INSPECTION OF THE CLUTCH DRUM

**General** If the clutch drum starts to tumble when the engine is idling with a sprocket with 11 teeth, this indicates a worn out bearing. Please replace the bearing immediately.

#### Instructions

1. Inspect clutch drum for signs of wear and replace if applicable.

### INSPECTION OF THE NEEDLE CAGE AND SPROCKET

**Instructions** See [Figure: Clutch drum, plain bearing / needle cage, sprocket](#)

1. Inspect the thrust washers (2) and (3) for signs of wear and replace if applicable.
2. Inspect the needle cage (4) or bearing sleeve for signs of wear and replace if applicable.
3. Inspect the teeth of the sprocket (5) for wear (compare) and replace if applicable.

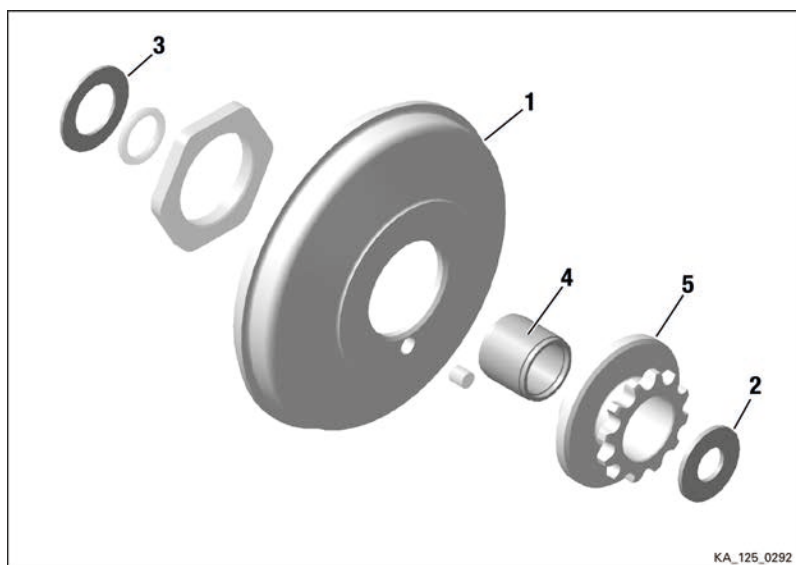

Figure 7.11: Clutch drum, plain bearing / needle cage, sprocket

- |                      |                               |
|----------------------|-------------------------------|
| 1 Clutch drum        | 2 Thrust washer               |
| 3 Thrust washer 15.2 | 4 Plain bearing / needle cage |
| 5 Sprocket           |                               |

### INSPECTION OF THE STARTER REDUCTION GEAR ASSY.

**General** NOTE

*In one direction of rotation the two gear wheels can be rotated together, in the other direction of rotation the two gears move apart and finally lock.*

# BRP-Rotax REPAIR MANUAL

**Instructions** See [Figure: Starter reduction gear assy.](#)

1. Clean starter reduction gear assy. (1).
2. Inspect the gear wheels (2) for wear.
3. Inspect the operation of the starter reduction gear assy.

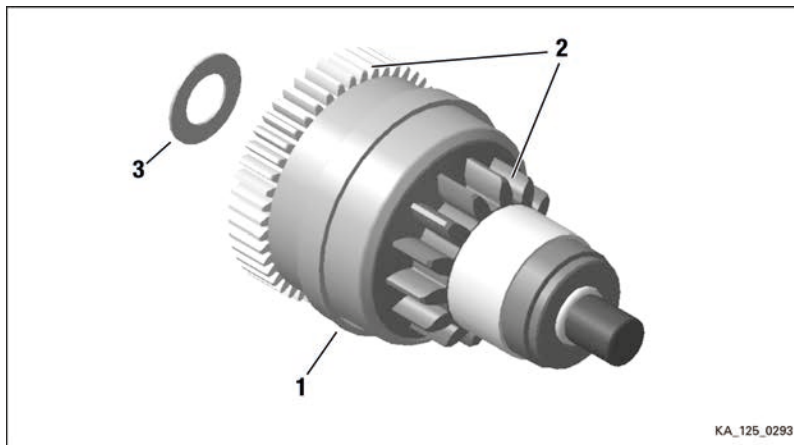

Figure 7.12: Starter reduction gear assy.

- |   |                        |   |             |
|---|------------------------|---|-------------|
| 1 | Starter reduction gear | 2 | Gear wheels |
| 3 | Thrust washer          |   |             |

## INSPECTION OF THE ELECTRIC STARTER

**General** **NOTE**

*If the electric starter is malfunctioning, the cause is generally that the two carbon brushes are worn or defective. In this case all parts in the electric starter repair kit must be renewed.*

**Instructions** See [Figure: Electric starter](#)

1. Check starter cable (1).

**NOTE**

If the starter cable is faulty, the starter cable assy. can be replaced.

2. Inspect parts of the electric starter.
3. Check teeth (2) for deformation and wear.

## BRP-Rotax REPAIR MANUAL

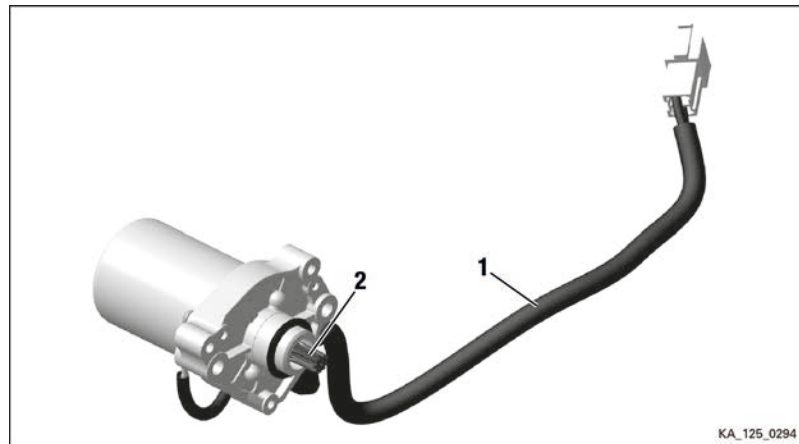

Figure 7.13: Electric starter

1 Starter cable

2 Teeth

### INSPECTION OF THE CLUTCH AND STARTER GEAR ASSY.

**Instructions** See [Figure: Clutch and starter gear assy.](#)

1. Check the hole (1) in the clutch (2).
2. Check the teeth of the starter gear assy. (3) for damage or deformation.
3. Remove LOCTITE residue from the taper (4) of the starter gear assy.

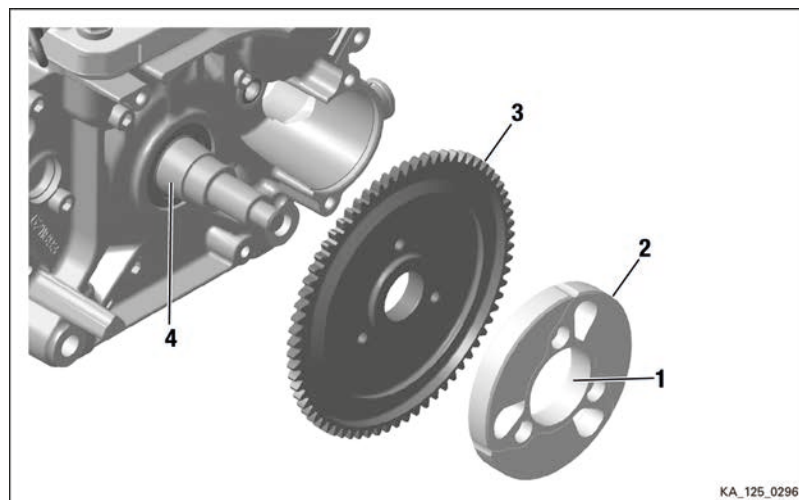

Figure 7.14: Clutch and starter gear assy.

1 Clutch hole

2 Clutch

3 Starter gear

4 Taper

# BRP-Rotax REPAIR MANUAL

## ELECTRIC STARTER REPAIR KIT

**Special tools** The following special tools and equipment are required:

Part no.	Description	Use
281262	Electric starter repair kit	Electric starter

**Instructions** See [Figure: Electric starter](#)

1. Remove the starter housing from the crankcase and gearbox case by unscrewing 2 Allen screws.
2. Disconnect electrical connection (5) from the starter (4).
3. Unscrew the starter housing screws (8).

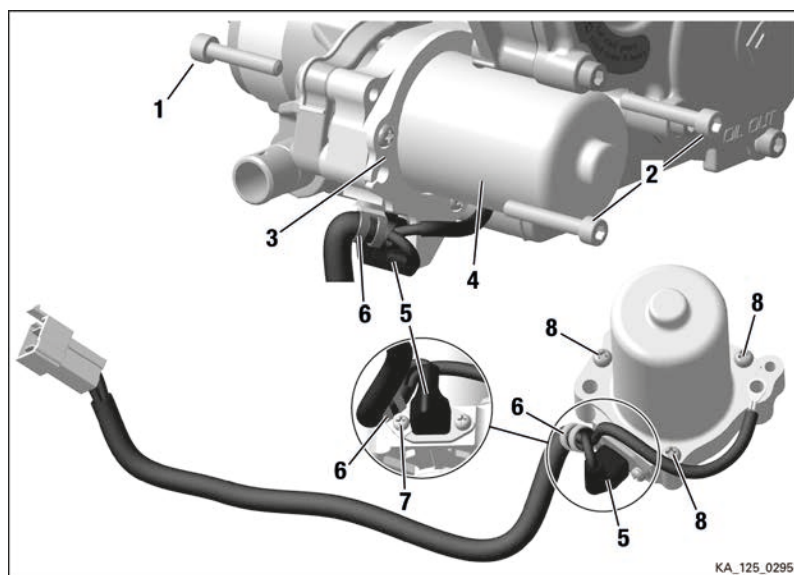

Figure 7.15: Electric starter

- |                                |                          |
|--------------------------------|--------------------------|
| 1 Allen screw M6x30            | 2 Allen screw M6x35      |
| 3 Starter support              | 4 Electric starter       |
| 5 Pick up sensor               | 6 Starter cable          |
| 7 Allen or TAPTITE screw M6x20 | 8 Starter housing screws |

## DISASSEMBLING OF ELECTRIC STARTER

**Instructions** See [Figure: Electric starter disassembly](#)

### NOTE

*Take care not to loose the spring-loaded sliding contacts.*

## BRP-Rotax REPAIR MANUAL

1. Secure the rotor shaft with a suitable tool.
2. Pull out solenoid housing.
3. Pull the rotor shaft from the starter motor support.
4. Unscrew the bracket for the positive contact.
5. Press out the rubber grommet.
6. Extract the positive contact by pulling it inwards through the plastic ring.

### NOTE

*If necessary, unscrew the rubber seal and the ground pole from the starter support and clean them.*



Figure 7.16: Electric starter disassembly

## ASSEMBLING OF ELECTRIC STARTER

### Instructions

### NOTE

*The brushes must contact the slip ring correctly.*

1. Inspect the carbon brushes and replace if necessary with new parts (ROTAX® part no. 281262).
2. Insert the plastic ring in the starter motor support so that it does not rotate.
3. Insert the positive contact from inside through the plastic ring and the cutout in the starter motor support.

## **BRP-Rotax** REPAIR MANUAL

4. Secure the plastic ring with two Phillips head screws and washers. The fixing provides the ground contact.
5. Install the rubber grommet over the positive contact.
6. Secure the bracket on the starter motor support.
7. Insert the coil springs in the cutouts of the plastic ring, press the brushes against them.
8. Carefully insert the rotor shaft.
9. Fill the starter motor support with LOCTITE 5910 in the region of the positive. This protects the fragile carbon brushes from vibration.
10. Insert the O-ring into the starter motor support.
11. Hold the rotor shaft with a suitable tool and secure the solenoid housing on the starter motor support.

# BRP-Rotax REPAIR MANUAL

## INSTALLATION OF CLUTCH AND STARTER GEAR ASSY.

**General** Follow the sequence exactly. The starter reduction gear assy. cannot be installed after insertion of the starter gear assy.

### INSTALLATION OF THE STARTER REDUCTION GEAR ASSY.

**Special tools** The following special tools and equipment are required:

Part no.	Description	Field of application
897330	Lithium-based grease	Starter drive

**Instruction** See [Figure: Starter reduction gear assy.](#)

1. Lubricate starter reduction gear assy. (1) with lithium-based grease in the area of the two bearing seats and the two gears.
2. Slide the thrust washer 8.1/150.5 (2) and starter reduction gear assy. (1) into the bearing seat in the housing together.

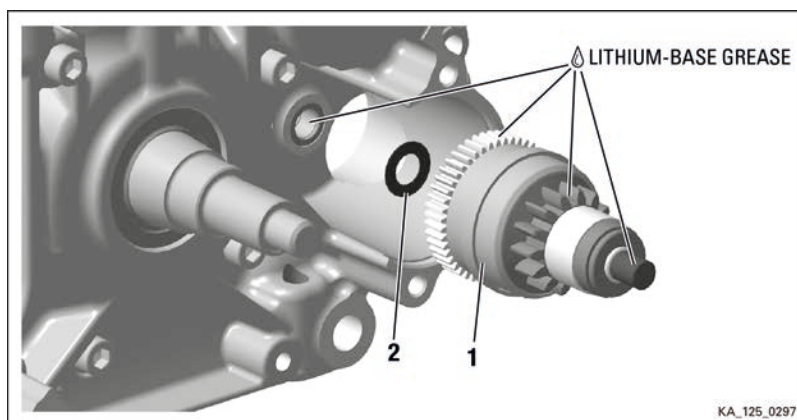

Figure 7.17: Starter reduction gear assy.

1 Starter reduction gear

2 Thrust washer

### INSTALLATION OF THE STARTER GEAR ASSY.

**Special tools** The following special tools and equipment are required:

Part no.	Description	Field of application
277381	Locking tool (crankshaft)	Spark plug thread
676205	Fixation tool assy.	Starter gear assy.
899788	LOCTITE 648	Starter gear assy.
897651	LOCTITE 243	Starter drive

# BRP-Rotax REPAIR MANUAL

## Instructions

1. Preferred version 1: screw in fixation tool for crankshaft (1) into the spark plug thread till the end stop.

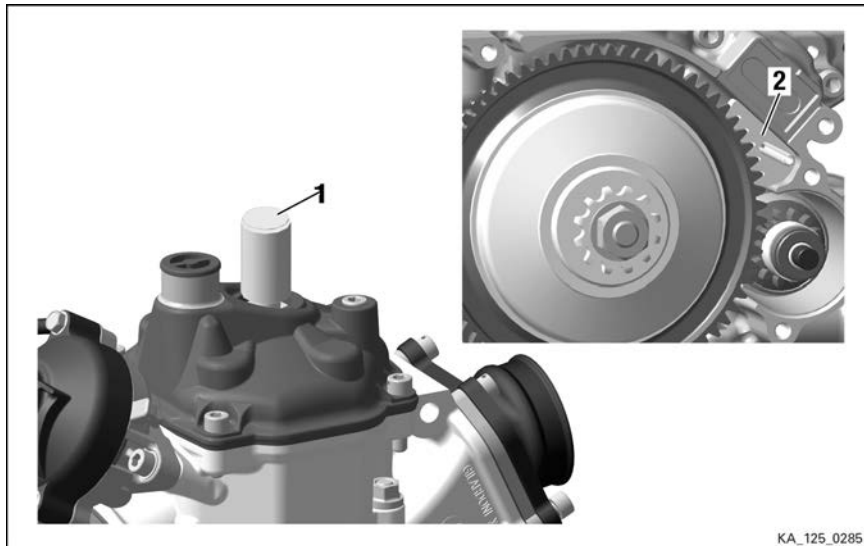

Figure 7.18: Fixation tools

1 Fixation tool (crankshaft)

2 Fixation tool (starter gear)

2. Version 2: insert fixation tool assy. (3) into the starter gear assy. (1).
3. Lubricate taper of starter gear assy. (1) with LOCTITE 648.
4. Install starter gear assy. (1) onto crankshaft and tighten with hex. nut M28x1 SW 30 H=4.6 (2). Tightening torque 120 Nm (89 ft. lb).
5. Wipe away the surplus LOCTITE.
6. Install the clutch (4) with 3 Allen screws M6x12 (5) and secure with LOCTITE 648. Tightening torque 17 Nm (150 in. lb).

# BRP-Rotax REPAIR MANUAL

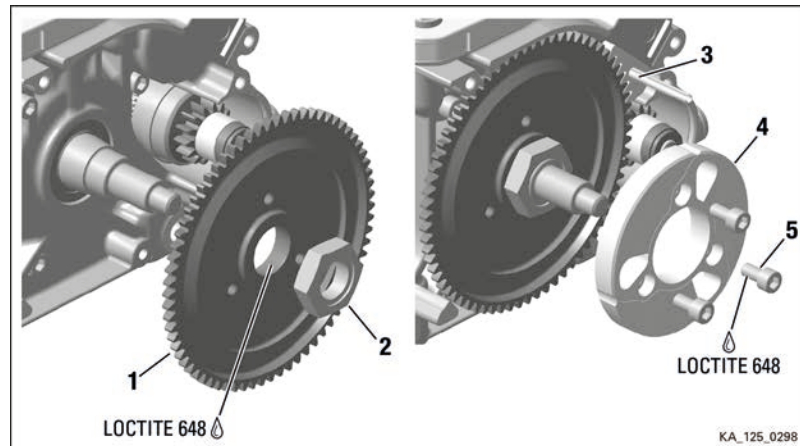

Figure 7.19: Starter gear assy.

- |                                |                  |
|--------------------------------|------------------|
| 1 Starter gear assy.           | 2 Hex. nut M28x1 |
| 3 Fixation tool (starter gear) | 4 Clutch         |
| 5 Allen screw M6x12            |                  |

## ASSEMBLY OF THE CLUTCH DRUM INSTALLATION OF THE SPROCKET

**Special tools** The following special tools and equipment are required:

Part no.	Description	Field of application
944231	Locating/locking device	Clutch drum
277362	Locating/locking device	Clutch drum
899788	LOCTITE 648	Hex. nut

**Instruction** See [Figure: Fixation tool](#)

1. Fix fixation tool for sprocket (1) in a vise.
2. Remove LOCTITE residue from the clutch drum (4) and the hex. nut (5).
3. Position clutch drum (4) on the sprocket (2) with needle pin (3).
4. Tighten hex. nut (5) and secure with LOCTITE 648. Tightening torque 100 Nm (74 ft.lb).

## BRP-Rotax REPAIR MANUAL

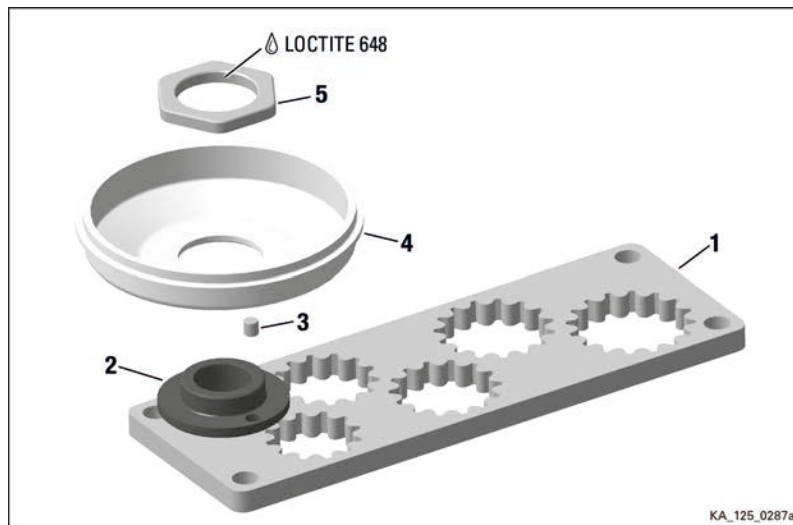

Figure 7.20: Fixation tool

- |   |               |   |             |
|---|---------------|---|-------------|
| 1 | Fixation tool | 2 | Sprocket    |
| 3 | Needle pin    | 4 | Clutch drum |
| 5 | Hex. nut.     |   |             |

### INSTALLATION OF BEARING SLEEVE (FOR SPROCKETS WITH 11 TEETH ONLY)

#### Special tools

The following special tools and equipment are required:

Part no.	Description	Field of application
676040	Installation tool	Sprocket

#### Instruction

See [Figure: Installation of bearing sleeve](#)

1. Put the new bearing sleeve (1) with the beveled edge (2) down onto the clutch drum with sprocket (11 teeth) and press with installation tool (part no. 676040) until end stop.

## BRP-Rotax REPAIR MANUAL

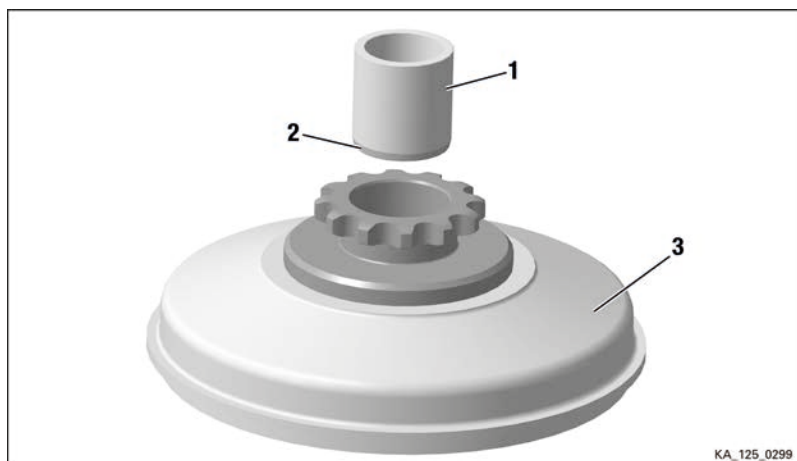

Figure 7.21: Installation of bearing sleeve

1 Bearing sleeve

2 Beveled edge

3 Clutch drum

### INSTALLATION OF THE CLUTCH DRUM

#### Safety

#### **⚠ WARNING**

#### **Risk of fatal injury!**

The engine must not be started without a clutch drum.

#### Special tools

The following special tools and equipment are required:

Part no.	Description	Field of application
897651	LOCTITE 243	Crankshaft thread
897330	Lithium-based grease	Running areas

#### Instruction

1. Lubricate crankshaft with lithium based grease in the running area of the needle cage (4).
2. Position thrust washer 15.2 (6) and O-ring (5) on the crankshaft.
3. Lubricate the needle cage (4) with lithium based grease and position on crankshaft.
4. Slide clutch drum (3) onto the crankshaft.
5. Lubricate the crankshaft with LOCTITE 243 in the thread area of the hex. nut.
6. Tighten hex. nut (1) with thrust washer (2) (machined side towards the clutch drum). Tightening torque 35 Nm (26 ft.lb).

## BRP-Rotax REPAIR MANUAL

7. Remove fixation tools for crankshaft and/or the starter gear assy.

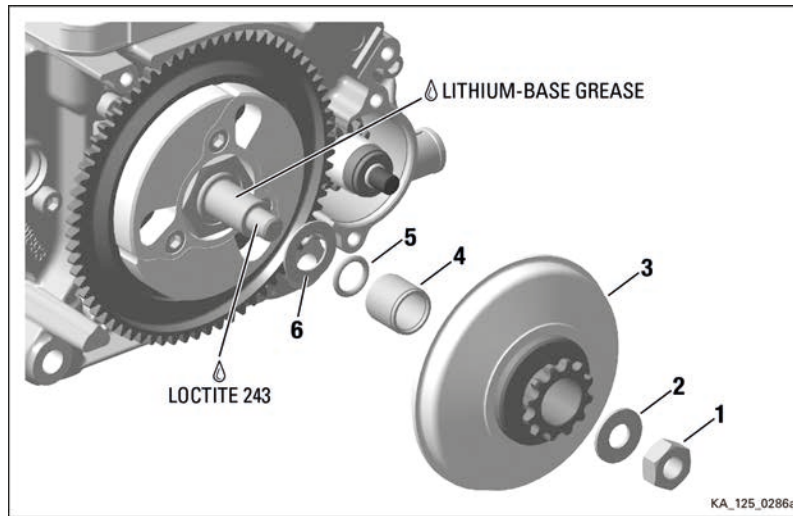

Figure 7.22: Clutch drum

- |                             |                      |
|-----------------------------|----------------------|
| 1 Hex. nut                  | 2 Thrust washer      |
| 3 Clutch drum with sprocket | 4 Needle cage        |
| 5 O-ring                    | 6 Thrust washer 15.2 |

8. Lubricate starter reduction gear assy. in the area shown in the following figure.
9. Install chain protection with 3 Allen screws M6x25. Tightening torque 5 Nm (44 in. lb).
10. Install spark plug. Tightening torque 24 Nm (18 ft. lb).

# BRP-Rotax REPAIR MANUAL

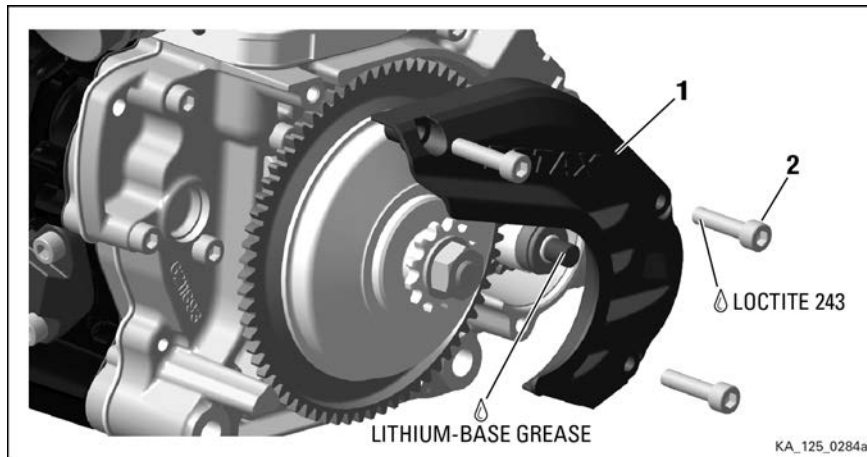

Figure 7.23: Chain protection

1 Chain protection

2 Allen screw M6x25

## INSTALLATION OF THE ELECTRIC STARTER

### Instructions

1. Lubricate O-ring (2) on the center of the electric starter (1).

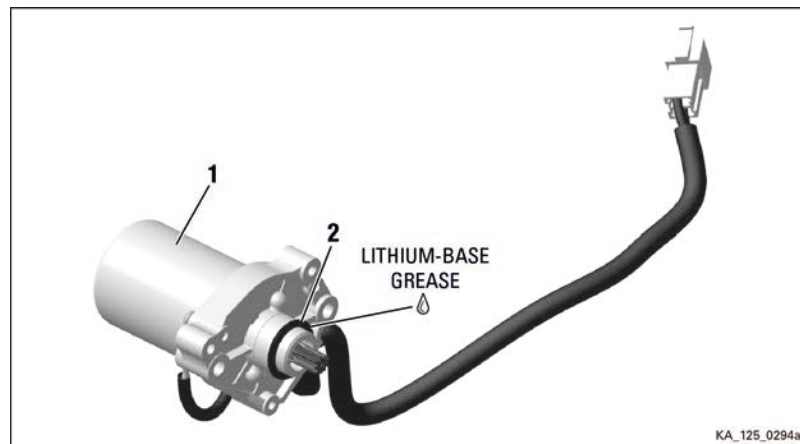

Figure 7.24

1 Electric starter

2 O-ring

2. Install starter support (2) with electric starter (1) using 2 Allen screws M6x35 (5). Tightening torque 10 Nm (89 in. lb).

# BRP-Rotax REPAIR MANUAL

## NOTE

Push the electric starter (1) into the centering of the housing (3) by rotating it back and forth until the teeth of the electric starter are meshed with the teeth of the starter reduction gear assy.

## NOTE

Do not forget to put on the ground cable (6).

3. Tighten Allen screw M6x30 (4) on the opposite side of the electric starter (1). Tightening torque 10 Nm (89 in. lb).

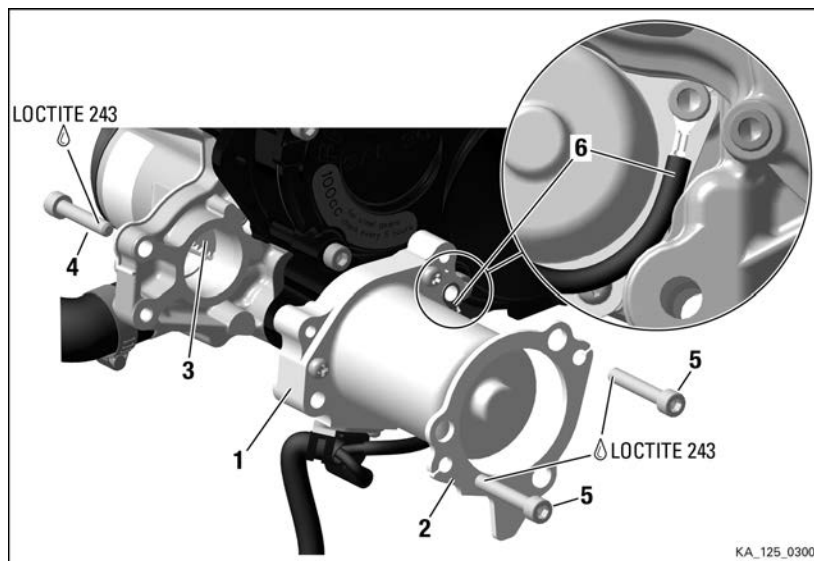

Figure 7.25

- |                               |                            |
|-------------------------------|----------------------------|
| 1 <i>Electric starter</i>     | 2 <i>Starter support</i>   |
| 3 <i>Centering of housing</i> | 4 <i>Allen screw M6x30</i> |
| 5 <i>Allen screw M6x35</i>    | 6 <i>Ground cable</i>      |

**BRP-Rotax**  
**REPAIR MANUAL**

**FILLING GEARBOX WITH OIL**

**General**

**NOTE**

*Take a measuring cup and fill with 100 ml of XPS® KART TEC GEAR OIL*

**Special tools**

The following special tools/equipment are required:

Part no.	Description	Field of application
25473.	XPS® KART TEC GEAR OIL	Gearbox

**Instructions**

See [Figure: Adding oil](#)

1. Remove air vent screw (1).
2. Add the specified volume of gear oil (100 ml) through the filling hole (2) in the housing.
3. Use sealing rings A6x10 for the Allen screws (3 = oil drain plug).
4. Screw in the vent screw (1) hand-tight.

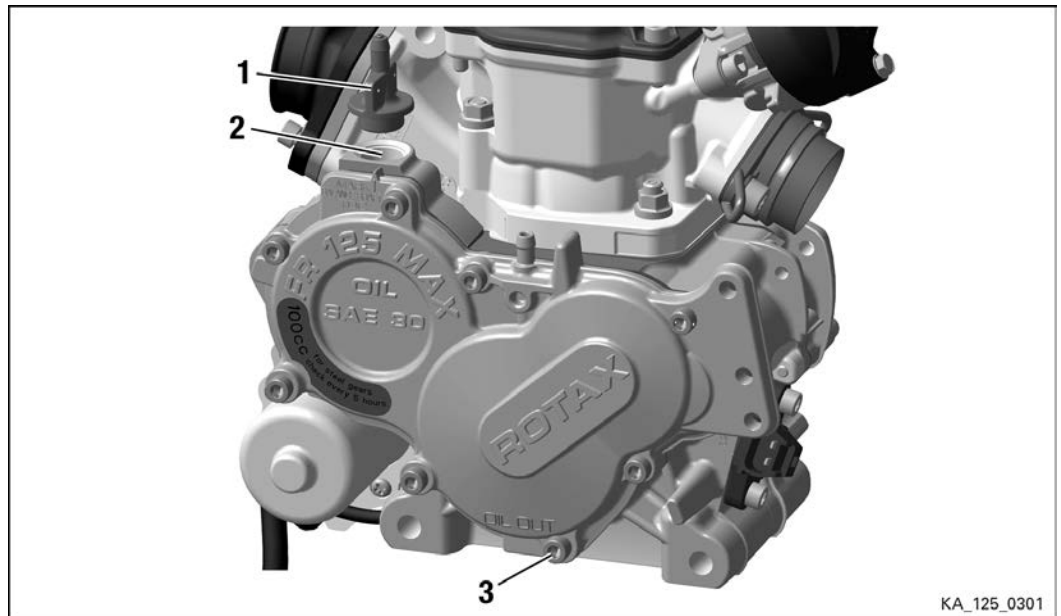

Figure 7.26: Adding oil

1 Air vent screw

2 Filling hole

3 Oil drain plug

**BRP-Rotax**  
REPAIR MANUAL

NOTES

**Chapter: Chapter 8**  
**COOLING SYSTEM**

**TOPICS IN THIS CHAPTER**

<b>System description</b> .....	<b>2</b>
<b>Removal of radiator</b> .....	<b>4</b>
Removal of the cooling water hose .....	4
<b>Inspection of cooling system</b> .....	<b>6</b>
Radiator – inspection of components .....	6
<b>Installing the radiator</b> .....	<b>7</b>
Installation of the cooling water hoses .....	7
Installation of the radiator on engine.....	8
<b>Final tasks</b> .....	<b>10</b>

**Contents**                      This chapter describes the removal and installation of the cooling system for the ROTAX® 125 MAX evo (incl. Junior-, Mini-, Micro MAX evo) engine. The description is broken down into subsections.

## SYSTEM DESCRIPTION

### Overview

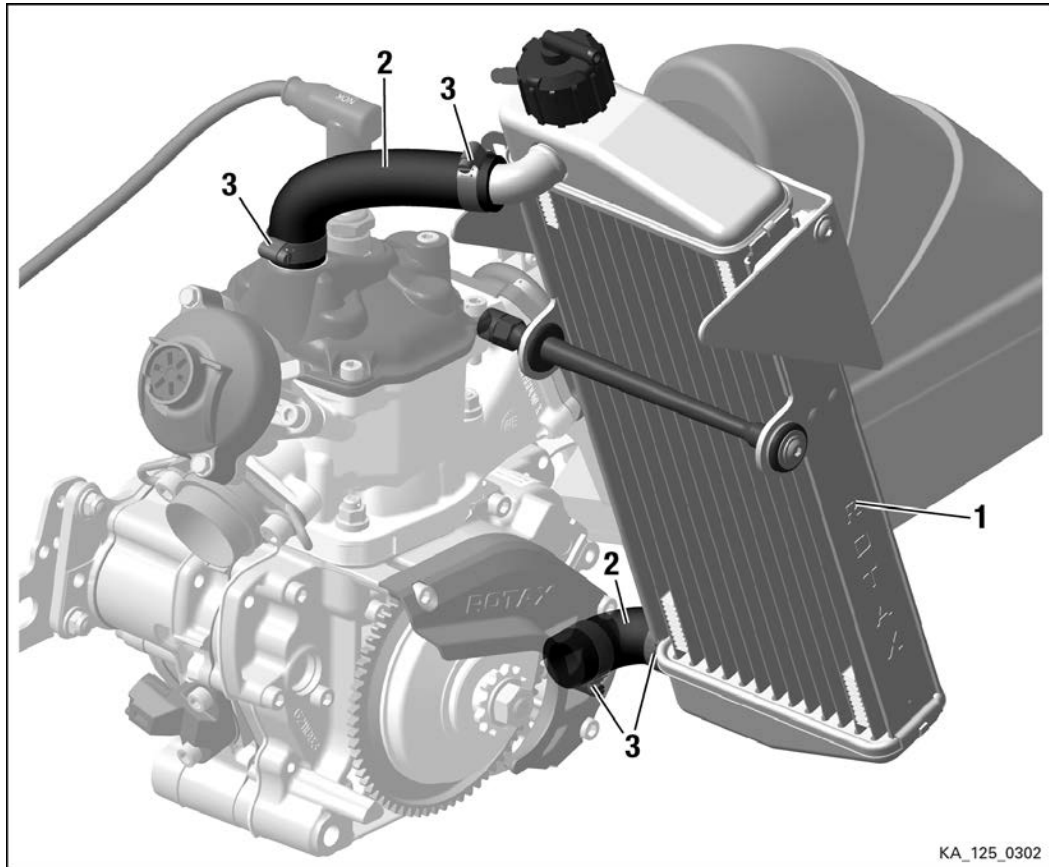

Figure 8.1: Radiator

1 Radiator

2 Cooling water hose

3 Hose clamp.

# BRP-Rotax REPAIR MANUAL

## Overview

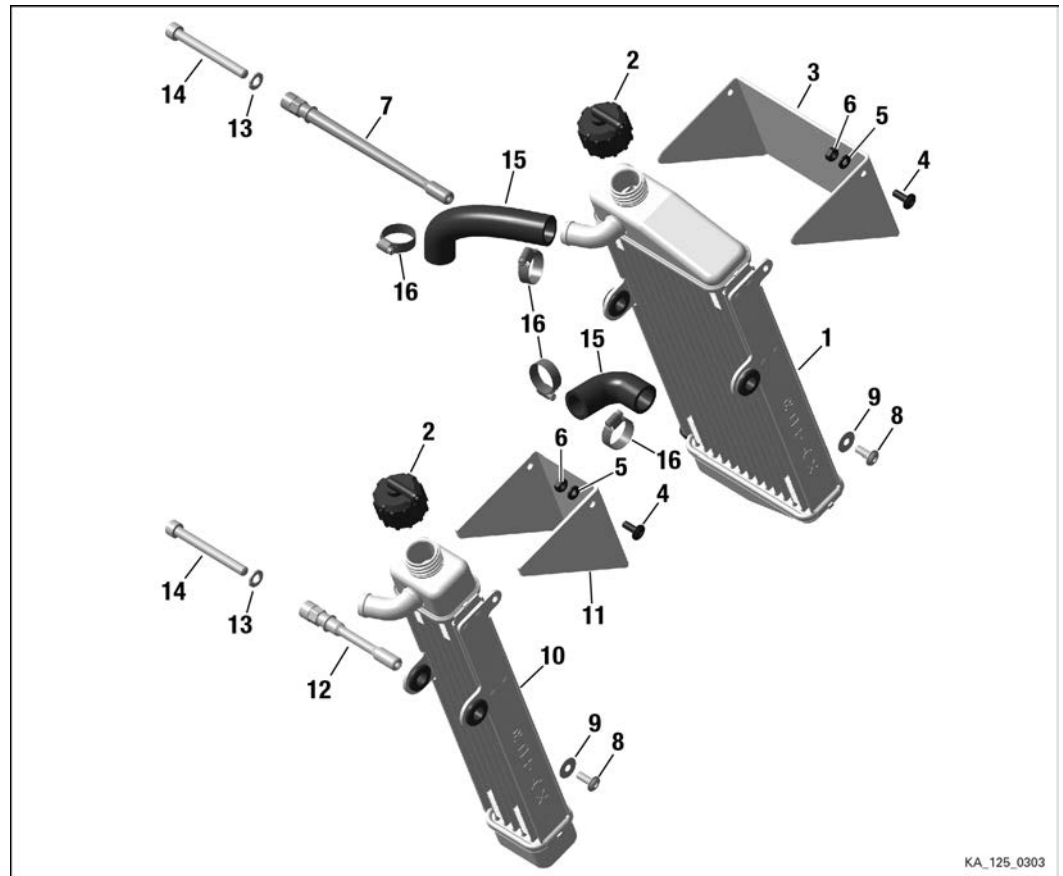

Figure 8.2: Water pump

- |  |  |
|--|--|
| 1 Radiator (Max evo, Junior evo, Mini evo)         | 2 Radiator cap with gasket                   |
| 3 Windshield (Max evo, Junior evo, Mini evo)       | 4 Allen screw M6x16 with rounded flange head |
| 5 Washer 6.4                                       | 6 Lock nut M6                                |
| 7 Radiator bracket (Max evo, Junior evo, Mini evo) | 8 Allen screw M6x20 with rounded flange head |
| 9 Washer 6.2                                       | 10 Radiator (Micro evo)                      |
| 11 Windshield (Micro evo)                          | 12 Radiator bracket (Micro evo)              |
| 13 Lock washer A8                                  | 14 Allen screw M8x75                         |
| 15 Cooling water hose NW 18                        | 16 Clamp 16-25                               |

**BRP-Rotax**  
**REPAIR MANUAL**

**REMOVAL OF RADIATOR**

**Safety  
instructions**

**⚠ WARNING**

**Danger of severe burns and scalds! Always allow the engine to cool down to ambient temperature before starting any work.**

**Preparation**      The following preparations should be carried out before removing the components:

1. Open the radiator cap.

**REMOVAL OF THE COOLING WATER HOSE**

**General**      **NOTE**

*Collect the coolant in a suitable vessel*

**Instructions**      See [Figure: Cooling water hoses](#)

1. Loosen the engine side of the hose clamps (2) of the cooling water hoses (1).
2. Pull off the radiator with cooling water hose from the bottom 90° elbow and drain coolant.
3. Pull of cooling water hose at the cylinder head cover. Unscrew the hose clamp and pull the cooling water hose from the port.
4. Loosen Allen screw M8x75 (3) with lock washer (4) and remove water radiator with radiator bracket from the engine.

# BRP-Rotax REPAIR MANUAL

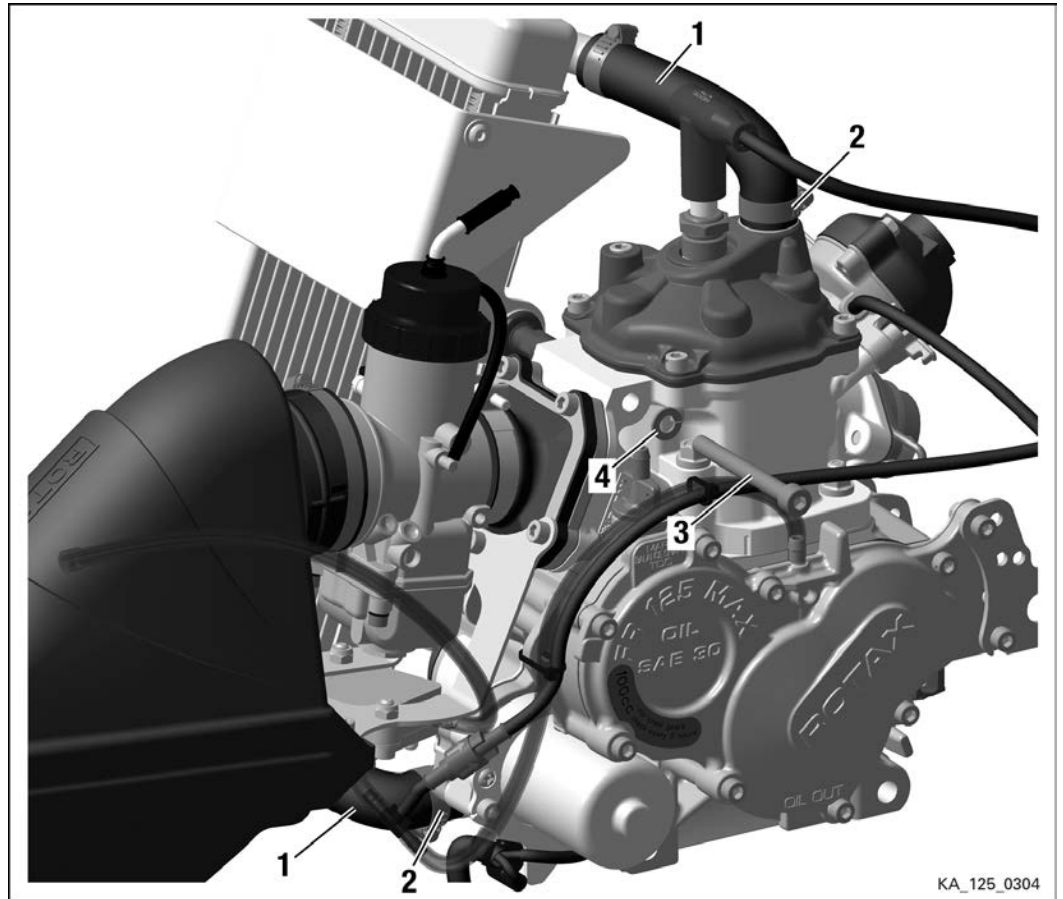

Figure 8.3: Cooling water hoses

1 Hoses

2 Hose clamps

3 Allen screw M8x75

4 Lock washer A8

# BRP-Rotax REPAIR MANUAL

## INSPECTION OF COOLING SYSTEM

### RADIATOR – INSPECTION OF COMPONENTS

**Instruction** See [Figure: Radiator](#).

#### NOTE

*If some of the cooling fins are slightly bent, they may be gently bent back into shape.*

1. Use compressed air to remove dirt from the cooling fins of the radiator. Never use a high-pressure cleaner.
2. Visual check of the radiator assy. for any cracks or other damage.
3. Check that the radiator cap gasket is in perfect condition.
4. Check the cooling water hoses for porosity and leakage.
5. Check the radiator's windshield for cracks and damage (visual check).
6. Check the rubber grommets for wear and cracks.

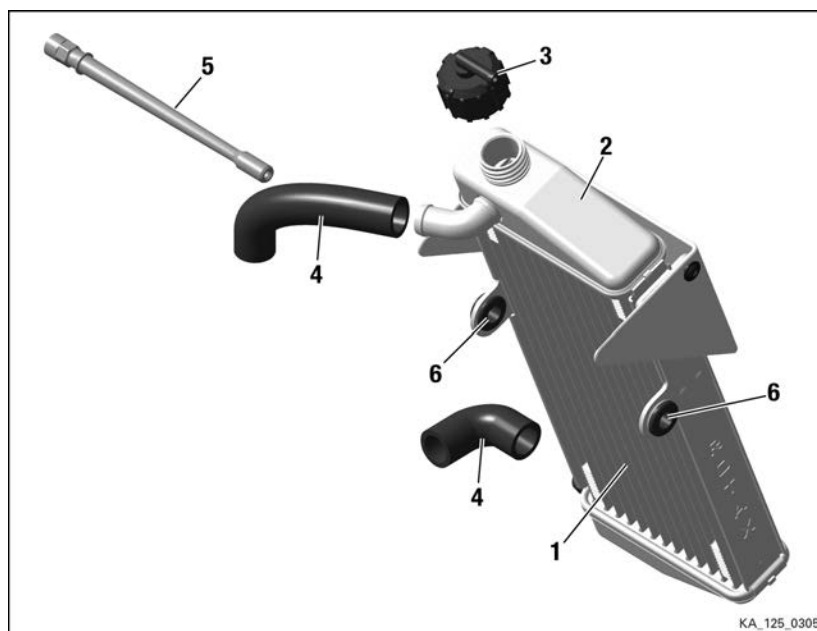

Figure 8.4: Radiator, typical

- |   |                  |   |                    |
|---|------------------|---|--------------------|
| 1 | Cooling fins     | 2 | Radiator           |
| 3 | Radiator cap     | 4 | Cooling water hose |
| 5 | Radiator bracket | 6 | Rubber grommet     |

## **INSTALLING THE RADIATOR**

### **INSTALLATION OF THE COOLING WATER HOSES**

#### **Preparation**

1. Mount radiator bracket (5) on radiator through the holes with rubber grommets and tighten with Allen screw M6x20 and washer 6.2.

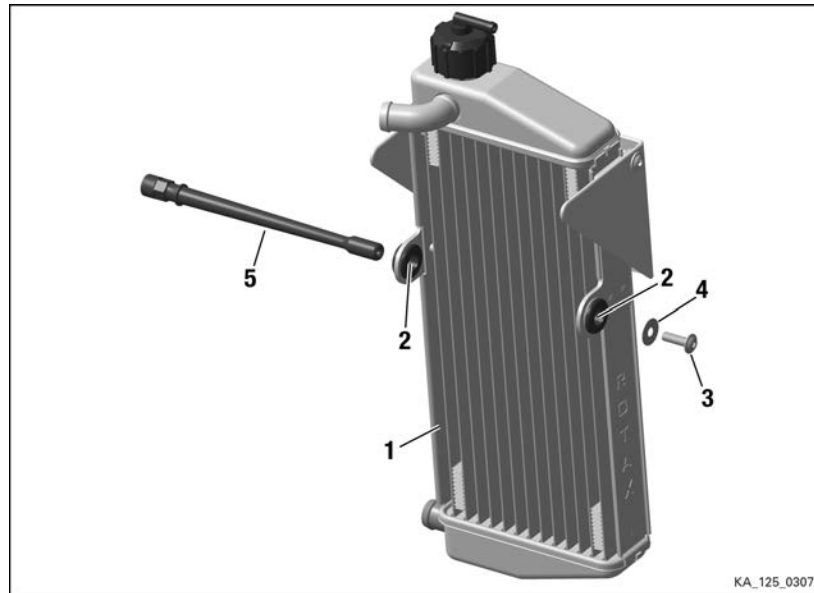

Figure 8.5: Preparation for radiator installation

- |  |                  |
|--|------------------|
| 1 Radiator                                   | 2 Rubber grommet |
| 3 Allen screw M6x20 with rounded flange head | 4 Washer 6.2     |
| 5 Radiator bracket                           |                  |

2. Fit the cooling water hoses (1) to the radiator connection (2) and align with the port on the engine, then tighten the hose clamps (3) to make it watertight.

## BRP-Rotax REPAIR MANUAL

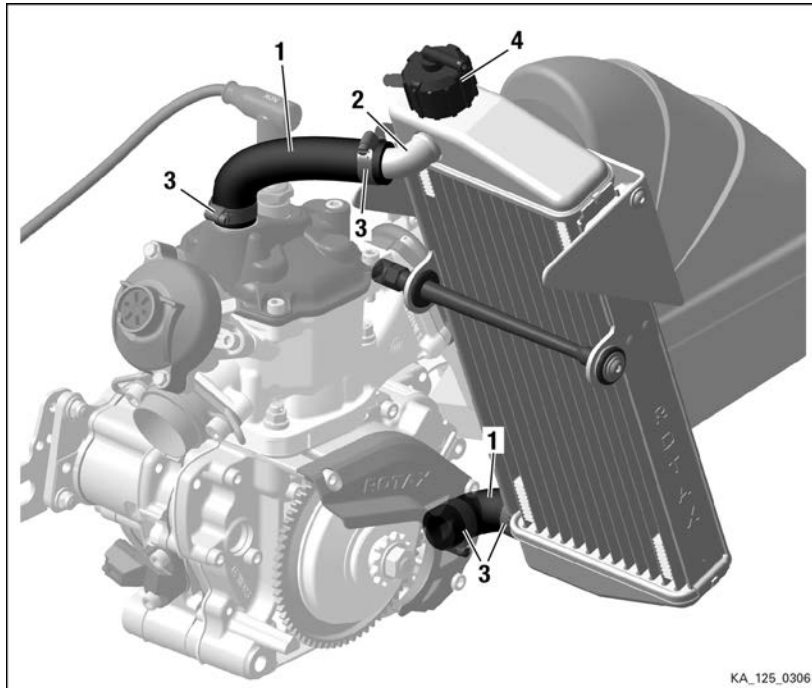

Figure 8.6: Installation of cooling water hoses

- |   |                     |   |                     |
|---|---------------------|---|---------------------|
| 1 | Cooling water hoses | 2 | Radiator connection |
| 3 | Hose clamps         | 4 | Radiator cap        |

### INSTALLATION OF THE RADIATOR ON ENGINE

**Instructions** See [Figure: Installation of the radiator on engine](#)

1. Install radiator with pre-mounted radiator bracket (3) on engine and tighten with Allen screw M8x75 (2) and Lock washer A8 (1). Tightening torque 24 Nm (18 ft. lb).

## BRP-Rotax REPAIR MANUAL

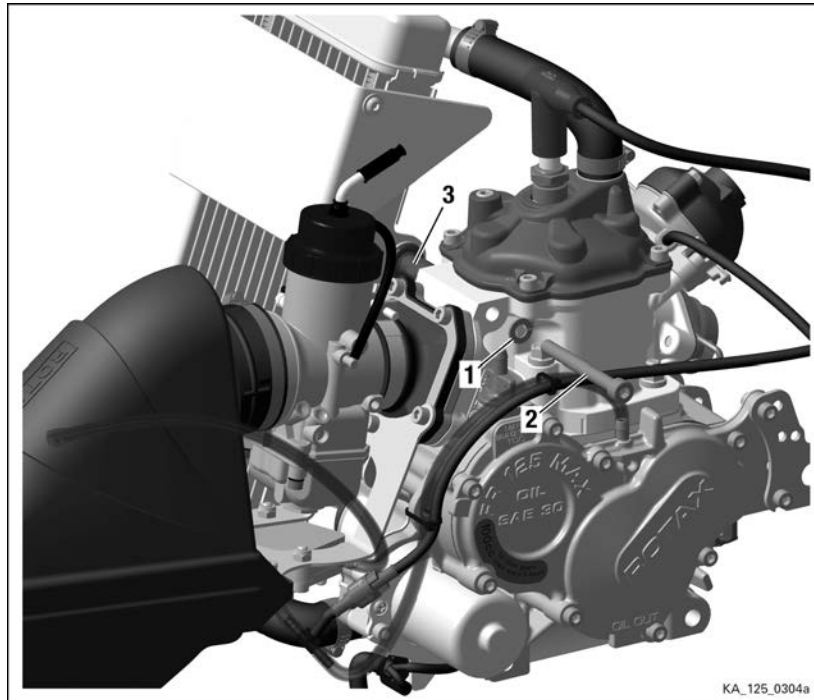

Figure 8.7: Installation of the radiator on engine

- |   |                                |   |                   |
|---|--------------------------------|---|-------------------|
| 1 | Lock washer A8                 | 2 | Allen screw M8x75 |
| 3 | Radiator with radiator bracket |   |                   |

**BRP-Rotax**  
REPAIR MANUAL

**FINAL TASKS**

Instructions

1. Using a funnel, pour the specified amount of coolant into the filling opening of the radiator.
2. Close the radiator cap.
3. Check that the cooling system is leak-free by warming up the engine.
4. Add some more coolant if necessary.

**BRP-Rotax**  
**REPAIR MANUAL**

**Chapter: Chapter 9**  
**EXHAUST SYSTEM**

**TOPICS IN THIS CHAPTER**

<b>System description .....</b>	<b>2</b>
<b>Removal of the exhaust system.....</b>	<b>4</b>
Checking the exhaust system .....	5
Disassembling the exhaust system .....	5
Assembling the exhaust system.....	5
Installation of the exhaust system .....	6
<b>Preparation for installation .....</b>	<b>7</b>
Removing the engine from the trestle mounting plate .....	7
Installation of the engine on kart chassis .....	7
Installation of the fuel line .....	7
Installation of the bowden cable.....	8
Installation of the ignition system .....	8
Installation of the exhaust system .....	9

**Contents**            This chapter describes the removal and installation of the exhaust system module of the ROTAX® 125 MAX evo (incl. Junior-, Mini-, Micro MAX evo) engine. The description is divided into sections.

## SYSTEM DESCRIPTION

### Overview

Position on the engine

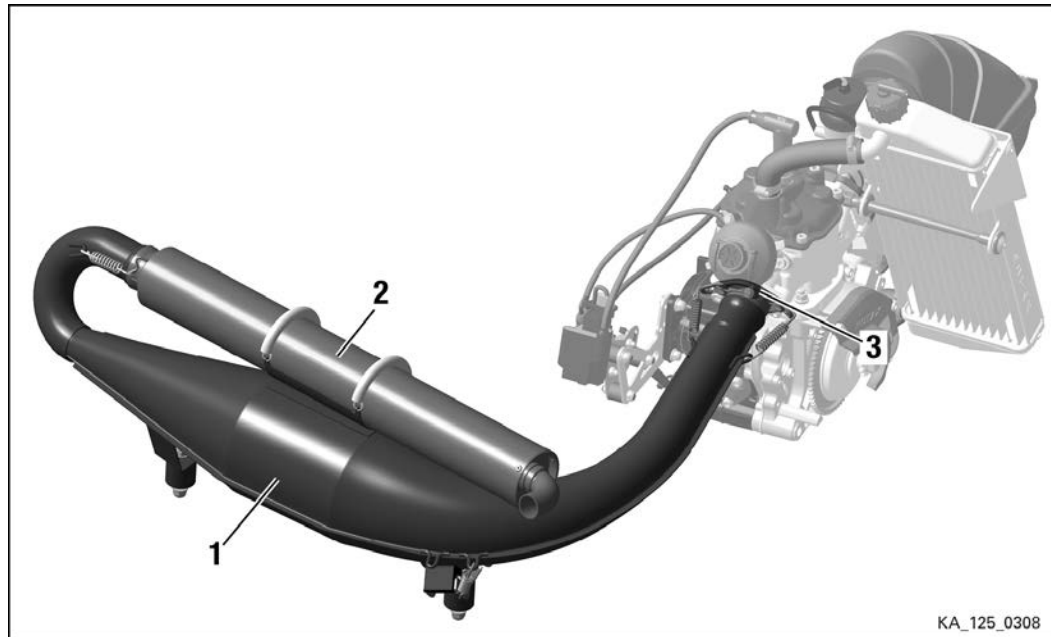

Figure 9.1

- 1 Exhaust muffler assy.
- 3 Exhaust socket assy.

- 2 Silencer assy.

# BRP-Rotax REPAIR MANUAL

## Overview

## Exhaust system

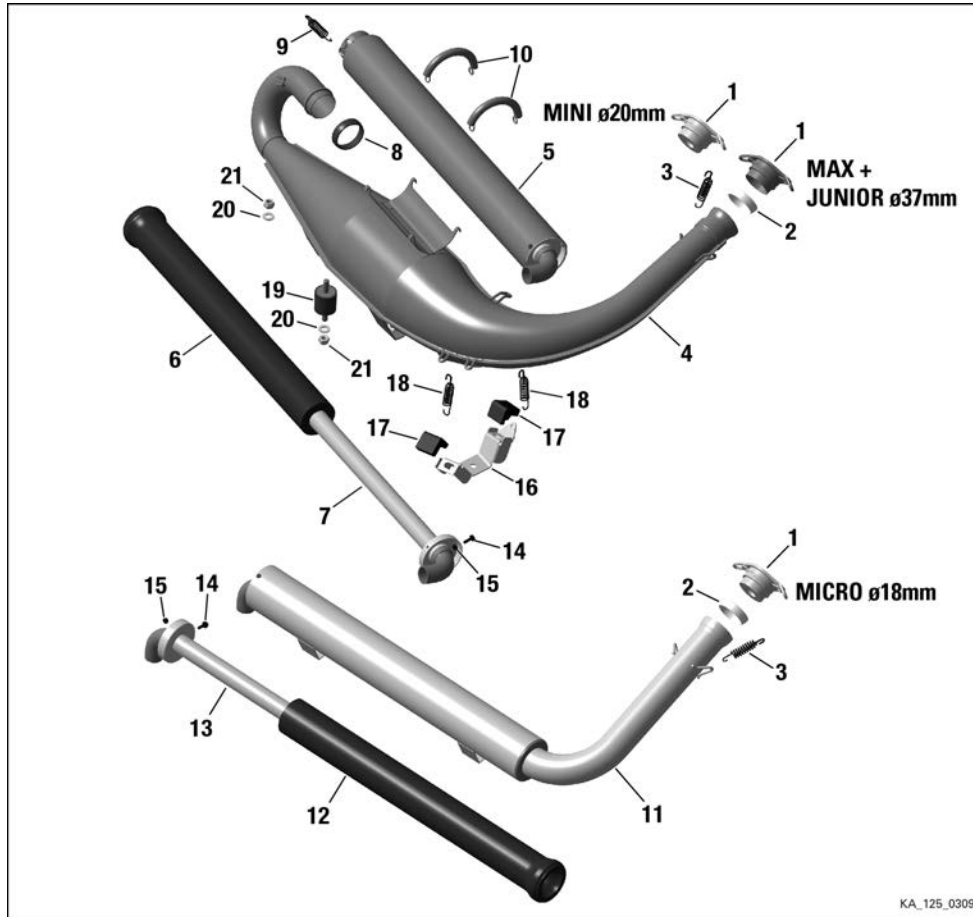

Figure 9.2

1	Exhaust socket assy.	2	Exhaust gasket	3	Spring stainless
4	Exhaust muffler assy.	5	Silencer assy.	6	Isolating mat
7	Perforated tube assy.	8	Exhaust gasket	9	Spring stainless
10	Tension springs	11	Silencer assy. MICRO	12	Isolating mat, MICRO
13	Perforated tube assy. MICRO	14	Washer 8.4 stain- less, MICRO	15	Lock nut M8, MICRO
16	Retaining plate	17	Rubber buffer	18	Spring stainless
19	Rubber buffer	20	Washer 8.4 stainless	21	Lock nut M8

## REMOVAL OF THE EXHAUST SYSTEM

### Safety instructions

**⚠ WARNING**

**Danger of severe burns and scalds! Always allow the engine to cool down to ambient temperature before starting any work.**

### Special tools

The following special tools and equipment are required:

Part no.	Description	Field of application
251680	Spring hook	Tension spring

### Instruction

Proceeds follows to dismantle the exhaust system:

1. Disconnect tension springs (3) with spring hooks from the exhaust socket (2).
2. Loosen the nuts M8 with washer on the rubber buffer and remove the exhaust system.
3. Take care about the exhaust gasket between exhaust socket and exhaust, replace if worn out.

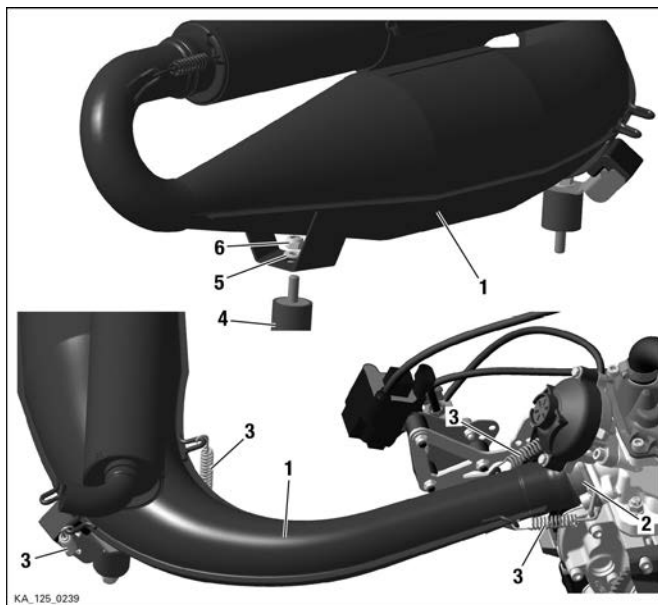

Figure 9.3

- |                        |                          |
|------------------------|--------------------------|
| 1 Exhaust muffer assy. | 2 Exhaust socket assy.   |
| 3 Spring               | 4 Rubber buffer 30x30xM8 |
| 5 Washer 8.4           | 6 Lock nut M8            |

## CHECKING THE EXHAUST SYSTEM

**ATTENTION**

**A worn isolating mat has a major engine damage as result!**

**Instructions**      See Figure

1. Check exhaust system for cracks, bending or other damages. Replace if necessary.
2. Clean the ball socket of combustion residue and inspect for wear.
3. Check that the cover rivets are tightly seated.
4. Check exhaust gasket for cracks and inspect for wear. Replace if necessary.
5. Check rubber buffer for cracks and inspect for wear. Replace if necessary.
6. Check the retaining plate for cracks and inspect for wear.

## DISASSEMBLING THE EXHAUST SYSTEM

**General**      **NOTE**

*If the exhaust system noise increases, then the silencer baffle mat should be replaced.*

**Instructions**      See [Figure: Exhaust system.](#)

1. Disassembly the exhaust muffler assy. and the silencer assy. Using the exhaust springs tool (part no .251680), remove exhaust springs. Remove the exhaust gasket.
2. Remove hex. collar screw M4x12 with lock nut from the silencer assy.
3. Remove old isolating mat.

## ASSEMBLING THE EXHAUST SYSTEM

**Instructions**      See [Figure: Exhaust system.](#)

1. Roll up new isolating mat (3) on the inside silencer assy. (2).
2. Put both into the exhaust system.
3. Install cover with Allen screw M4x12 (6) and new lock nut M4 (5).
4. Install a new exhaust gasket (7).
5. Make sure front exhaust pipe end is properly aligned inside ball socket. Install 3 exhaust spring (8)

## BRP-Rotax REPAIR MANUAL

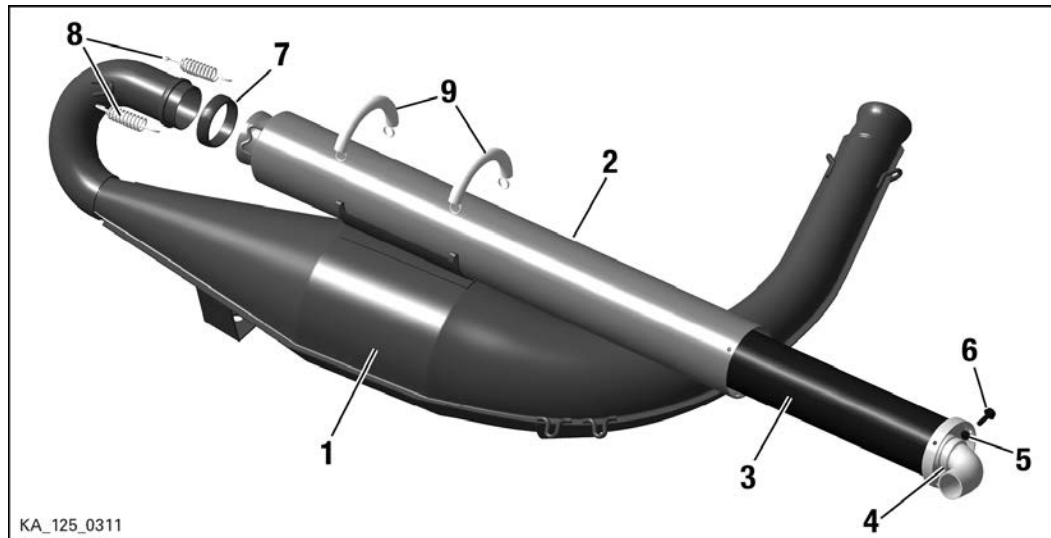

Figure 9.4: Exhaust system

- |                         |                         |
|-------------------------|-------------------------|
| 1 Exhaust muffler assy. | 2 Silencer assy.        |
| 3 Isolating mat         | 4 Perforated tube assy. |
| 5 Lock nut M4           | 6 Allen screw M4x12     |
| 7 Exhaust gasket        | 8 Spring stainless      |
| 9 Tension spring        |                         |

### INSTALLATION OF THE EXHAUST SYSTEM

#### Instructions

For installation of the exhaust system, see latest Installation Manual for the engine type 125 MAX evo.

## PREPARATION FOR INSTALLATION

### Safety instructions

#### ATTENTION

Clean and inspect disassembled parts and assemble them in accordance with the instructions. All screws and nuts must always be clean. Inspect surfaces and threads for damage. In case of doubt use new screws and nuts.

## REMOVING THE ENGINE FROM THE TRESTLE MOUNTING PLATE

**Instructions** Proceed as follows to remove the engine from the trestle mounting plate:

1. The engine is removed in reverse order of positioning.  
See also Chapter [Positioning the engine on the trestle mounting plate](#).

## INSTALLATION OF THE ENGINE ON KART CHASSIS

### Safety instructions

#### ⚠ WARNING

##### **Non-compliance can result in serious injuries or death!**

Before installing the engine on the chassis the Installation and Operators Manual for the engine and the installation instructions of the chassis manufacturer must be read and understood.

For the Installation of the engine on kart chassis, see latest current Installation and Operators Manual of the engine type 125 MAX.

## INSTALLATION OF THE FUEL LINE

### Safety instructions

#### ⚠ WARNING

##### **Non-compliance can result in serious injuries or death!**

When handling with fuel, do not smoke or allow open flames. Gasoline and gasoline vapor are highly flammable and explosive under certain conditions.

#### ⚠ WARNING

##### **Risk of fire and explosion!**

Make sure that fuel will not splash onto hot engine components or equipment.

# BRP-Rotax REPAIR MANUAL

**Instructions** Proceed as follows to install the fuel line:

1. The installation of the fuel line is identical to the removal, but in reverse order.  
See also [Removal of the fuel line](#)

## INSTALLATION OF THE BOWDEN CABLE

**Instructions** Proceed as follows to install the bowden cable:

1. The installation of the bowden cable is identical to the removal, but in reverse order.  
See also [Removal of the Bowden cable](#)

## INSTALLATION OF THE IGNITION SYSTEM

**General** See [Figure: Ignition unit](#).

### NOTE

*On the sand-cast model the pick up for the ignition unit is fastened to the housing with 2 M6x16 cyl. screws. On the die-cast model the pick up for the ignition unit is fastened to the housing with 2 M6x16 TAPTITE screws (= self-tapping screw).*

### NOTE

*If the two TAPTITE screws are installed in a previously used housing, make sure that the screws are correctly positioned in the previously tapped threads in the housing.*

**Instructions** Proceed as follows to install the ignition system:

1. Position the pick up on the housing with the wiring harness terminal pointing in the direction of the gearbox.
2. Fasten the pick up for the ignition system with the two cyl. screws or TAPTITE screws to the specified tightening torque of 10 Nm (90 in.lb).

# BRP-Rotax REPAIR MANUAL

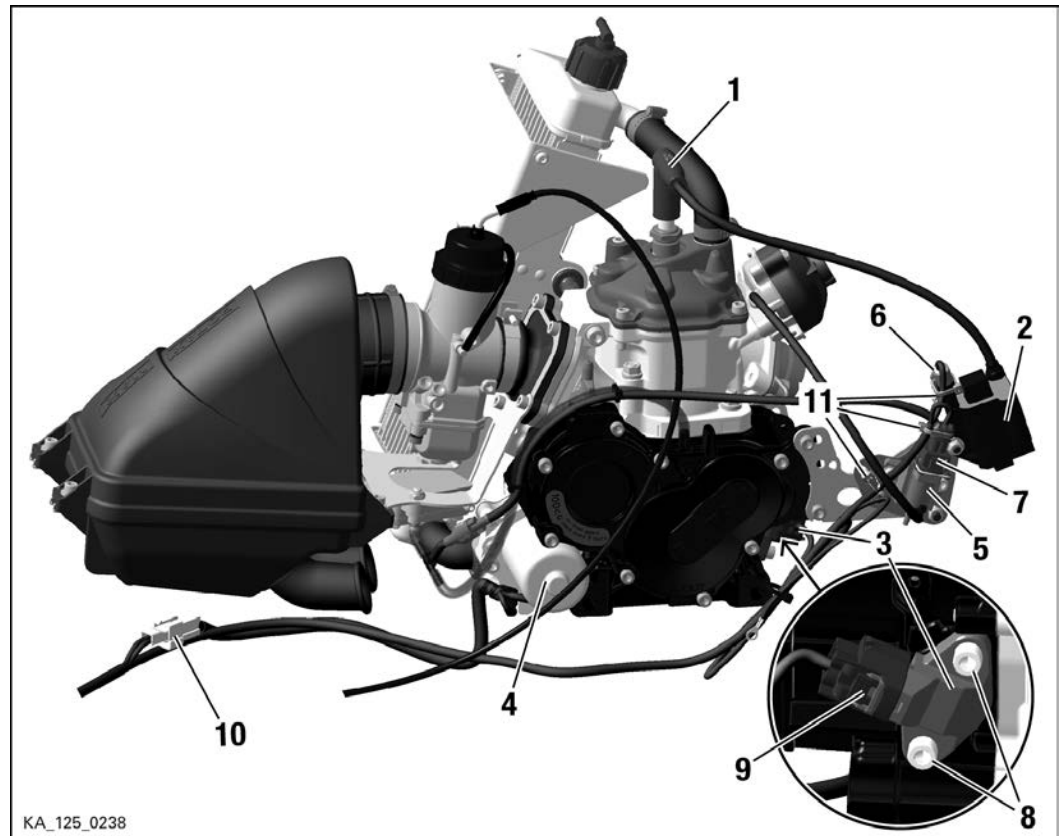

Figure 9.5: Ignition unit

- |                                       |                           |
|---------------------------------------|---------------------------|
| 1 Spark plug connector                | 2 Ignition coil           |
| 3 Crankshaft positioning sensor (CPS) | 4 Electric starter        |
| 5 Solenoid valve                      | 6 Connector ignition coil |
| 7 Solenoid connector                  | 8 Allen screw M6x25       |
| 9 CPS connector                       | 10 Starter connector      |
| 11 Cable tie                          |                           |

## INSTALLATION OF THE EXHAUST SYSTEM

### Instructions

For installation of the exhaust system, see latest Installation Manual for the engine type 125 MAX evo.

**BRP-Rotax**  
REPAIR MANUAL

NOTES

# BRP-Rotax REPAIR MANUAL

## Index

### A

Abbreviations.....	3
Assembling of electric starter .....	15
Assembling the exhaust system .....	5
Assembly of carburetor.....	11
Assembly of crankshaft, water pump shaft and balance shaft .....	35
Assembly of float housing .....	11
Assembly of housing halves.....	36
Assembly of intake silencer.....	12
Assembly of the clutch drum .....	19
Authorized personnel .....	3

### C

Carburetor and intake silencer – inspection of components .....	8
Checking the exhaust system.....	5
combustion chamber insert installation .....	29
Consumable materials.....	6
Crank case assembly .....	30
Crankshaft assembly.....	22
Crankshaft not in specification.....	21
cylinder components inspection.....	11
cylinder components installation.....	21
Cylinder installation .....	25
Cylinder removal.....	3

### D

disassembling crankcase.....	11
Disassembling crankcase .....	9
Disassembling of electric starter.....	14
Disassembling of the crankshaft.....	15
Disassembling the exhaust system.....	5
Disassembly of the carburetor.....	5
Disassembly of the intake silencer.....	7
Drain oil.....	5

### E

Electric starter repair kit.....	14
Exhaust valve installation.....	21
Exhaust valve, gasket, valve rod housing.....	22
Exhaust valve, piston.....	22

### F

Filling gearbox with oil .....	25
Final tasks .....	10

### G

General note.....	2
-------------------	---

### I

Inspection and adjustment of squish gap.....	31
Inspection of balance shaft .....	28
Inspection of balance shaft drive .....	27
Inspection of clutch and starter gear assy.....	11
Inspection of cooling system .....	6
Inspection of crankshaft.....	19
Inspection of cylinder components.....	11
Inspection of intake silencer .....	9
Inspection of piston and piston ring.....	12
Inspection of the carburetor.....	8
Inspection of the carburetor flange and reed valve .....	19
Inspection of the clutch and starter gear assy. ....	13
Inspection of the clutch drum.....	11
Inspection of the combustion chamber insert.....	17
Inspection of the cylinder head cover .....	17
Inspection of the electric starter .....	12
Inspection of the exhaust socket.....	18
Inspection of the fuel pump .....	9
Inspection of the housing halves.....	29
Inspection of the needle cage and sprocket.....	11
Inspection of the spark plug .....	15
Inspection of the starter reduction gear assy.....	11
inspection of water pump drive .....	26
Inspection of water pump shaft.....	27
Installation of balance and water-pump shaft drive .....	37
Installation of Ball bearing and oil seal for crankcase .....	32
Installation of bearing sleeve .....	20
Installation of clutch and starter gear assy. ....	17
Installation of crankcase assy.....	37
Installation of cylinder head cover.....	29
Installation of fuel pump, carburetor .....	13
Installation of oil seal, ball bearing and needle bushing.....	30
Installation of piston.....	24

# BRP-Rotax REPAIR MANUAL

Installation of spark plug .....	33	Removal of the clutch and starter gear assy.....	4
Installation of the bowden cable.....	8	Removal of the clutch drum.....	5
Installation of the carburetor flange and reed valve .....	27	Removal of the combustion chamber insert .....	6
Installation of the clutch drum .....	21	Removal of the cooling water hose .....	4
Installation of the cooling water hoses .....	7	Removal of the crankcase.....	5
Installation of the crankshaft repair kit .....	15	Removal of the cylinder head cover .....	4
Installation of the electric starter .....	23	Removal of the electric starter .....	4
Installation of the engine on kart chassis .....	7	Removal of the engine from kart chassis .....	8
Installation of the exhaust socket .....	26	Removal of the exhaust socket.....	7-8
Installation of the exhaust system .....	6, 9	Removal of the exhaust system.....	6, 4
Installation of the ignition system .....	8	Removal of the fuel line .....	7
Installation of the radiator on engine .....	8	Removal of the ignition system .....	3
Installation of the sprocket .....	19	Removal of the intake socket and reed valve .....	8
Installation of the starter gear assy.....	17	Removal of the piston .....	10
Installation of the starter reduction gear assy. ....	17	Removal of the spark plug.....	4
Installing the carburetor and intake silencer.....	11	removal of the sprocket .....	7
Installing the radiator .....	7	Removal of the starter gear assy. ....	8
Instruction .....	5	Removal of the thermostat .....	5
INTRO .....	1	Remove water pump and compensating wheels .....	6
		Removing the engine from the trestle mounting plate .....	7
<b>P</b>			
Piston and cylinder sizing.....	14	<b>S</b>	
Piston diameter .....	13	Safety .....	4
Piston pin, circlip .....	15	Safety notice.....	4
Process advice .....	4	Special tools .....	8
<b>R</b>			
Radiator – inspection of components .....	6	<b>T</b>	
Removal of radiator .....	4	Technical data.....	7
Removal of radiator with cap assy.....	6	<b>U</b>	
Removal of the Bowden cable .....	8	Use for intended purpose.....	6
Removal of the carburetor and intake silencer .....	3		
Removal of the centrifugal clutch assy.....	4		

**ROTAX**<sup>®</sup>  
KARTING

