

Installation instructions and Operator's Manual

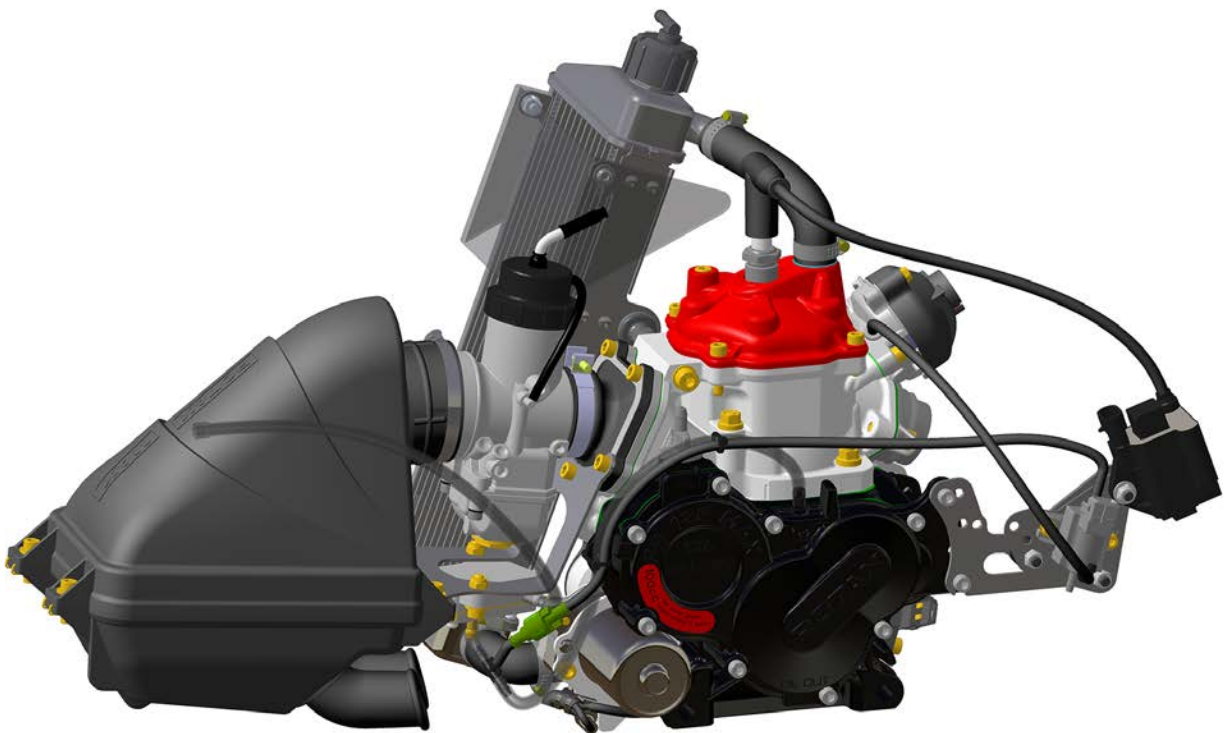

for ROTAX[®]-engines type

125 MAX evo

125 JUNIOR MAX evo

125 MINI MAX evo

125 MICRO MAX evo

Part no.: 297732

Edition: 10/2019

General information

BRP-Rotax recommends products of the following companies:



For information regarding the repair of the engines 125 MAX evo/Junior MAX evo/Mini MAX evo/Micro MAX evo contact an authorized service center or consult the workshop manual (available on the internet at www.rotax-kart.com).

We ask to hand over this manual, the engine identity card and the product and service registration document to the new owner in case of a change of ownership.

Preface

This document and all technical data and procedures therein are property of BRP-Rotax GmbH & Co KG and are based on the state of knowledge at the time of publication. The manual has been drawn up to the best of our knowledge. However, we exclude any liability.

We reserve all rights including technical modification and possibility of errors. Reprinting, translation or copies in whole or in part, are authorized only after written permission by BRP-Rotax GmbH & Co KG.

BRP-Rotax GmbH & Co KG reserves the right at any time to discontinue or change specifications, prices, designs, features, models or equipment without incurring any obligations.

Engine performance may vary depending on, among other things, general conditions, ambient temperature and altitude.



BRP-Rotax
INSTALLATION INSTRUCTION

Table of Content

Chapter	INTRO –
Chapter	1 – Engine installation
Chapter	2 – Fuel system
Chapter	3 – Electric system
Chapter	4 – Cooling system
Chapter	5 – Exhaust system
Chapter	6 – Installation of the accessories
Chapter	7 – Finishing work

BRP-Rotax
INSTALLATION INSTRUCTION

NOTES

Notes

Page 2
Edition: October 01 2019

Effectivity: 125 MAX evo, Junior MAX
evo, Mini MAX evo, Micro MAX evo
Edition October 01 2019/Rev. 0

BRP-Rotax INSTALLATION INSTRUCTION

Chapter: INTRO

Preface

For information regarding repair of the engine 125 MAX contact an authorized service center or consult the workshop manual (available on internet under www.rotax-kart.com).

Also check our YouTube-Channel for interesting HowTo-videos:



Figure 1.1: QR code, HowTo-videos

We ask to hand over this manual, the engine identity card and the product and service registration document to the new owner in case of a change of ownership.

Contents

This Installation Manual contains instructions for all the installation work on the ROTAX®-Engine Type 125 MAX evo, 125 Junior MAX evo, 125 Mini MAX evo and 125 Micro MAX evo.

General

This document and all technical data and procedures therein are property of BRP-Rotax GmbH & Co KG and based on the state of knowledge at the time of publication. The Manual has been drawn up to the best of our knowledge. However, excluding any liability.

We reserve all rights including technical modification and possibility of errors. Reprinting, translation or copies in whole or in part, are authorized only after written permission by BRP-Rotax GmbH & Co KG.

BRP-Rotax GmbH & Co KG reserves the right at any time to discontinue or change specifications, prices, designs, features, models or equipment without incurring obligation. Engine performance may vary depending on, among other things, general conditions, ambient temperature and altitude.

NOTE

The registration document and engine identity card must be provided to the final consumer upon delivery by the authorized service center with handover date and company stamp.

NOTE

The data entered in the registration document and/or engine identity card is required for the verification of a warranty claim. Without a completely filled-in engine identity card, no warranty claim will be granted.

BRP-Rotax

INSTALLATION INSTRUCTION

NOTE

In case of participating in the ROTAX® MAX CHALLENGE (RMC) the engine must be verified for conformity with the technical regulations and sealed. The serial number of the seal must be entered in the engine identity card.

Symbols used

This Manual uses the following symbols to emphasize particular information. This information is important and must be observed.

WARNING

Identifies an instruction, which if not followed may cause injury or endanger the life of the driver, mechanic or third party.

ATTENTION

Identifies an instruction which, if not followed may cause injury or endanger the life of the driver, mechanic or third party.

ENVIRONMENTAL NOTE

Environmental notes give you tips on environmental protection.

NOTE

Indicates supplementary information which may be needed to fully complete or understand an instruction.

✓ Denotes a checking operation

TIP This information gives you additional advice and tips

BRP-Rotax

INSTALLATION INSTRUCTION

Safety information

⚠ WARNING

Non-compliance can result in serious injuries or death!

For the best possible engine operation, compliance with the following advice regarding installation of engine and equipment is required.

⚠ WARNING

Non-compliance can result in serious injuries or death!

Engine operation is permitted only with equipment supplied by ROTAX®

⚠ WARNING

Non-compliance can result in serious injuries or death!

Besides the engine-specific installation advice, also take note of information from the respective chassis manufacturer.

Introduction

Congratulations on choosing the ROTAX engine Type 125 MAX.
The ROTAX® engine Type 125 MAX has been developed exclusively for use in Go-karts, which must only be run on specified tracks. This product has numerous technical innovations.

⚠ WARNING

Non-compliance can result in serious injuries or death!

Before starting with installation and operation of the engine, observe the installation instructions and Operator's Manual and follow all instructions.

⚠ WARNING

Non-compliance can result in serious injuries or death!

This engine performs better as comparable products

BRP-Rotax INSTALLATION INSTRUCTION

UNBOXING AND PURCHASED PARTS PACKAGE

By buying a ROTAX Engine, you will receive two boxes. The engine box and the accessory box.



KA_125_0316

Figure 1.2: Unboxing

Engine box

The engine box contains the pre-assembled engine with the secure sticker, which describes the run-in procedure. Take the engine out of the box.

Accessory box

The accessory box contains all required parts for running the engine. Lay down all parts, so you have a good overview of the parts. Check, if all parts of the following table are delivered.

BRP-Rotax INSTALLATION INSTRUCTION



KA_125_0326

Figure 1.3: Accessory box

Pos.	Description	Check mark
1	Radiator with coolant hoses	<input type="checkbox"/>
2	Mounting plate with ignition coil, solenoid valve and spark plug cap	<input type="checkbox"/>
3	Battery box and wiring harness	<input type="checkbox"/>
4	Battery charger	<input type="checkbox"/>
5	Intake silencer	<input type="checkbox"/>
6	Fuel pump with fuel hose	<input type="checkbox"/>
7	Exhaust system	<input type="checkbox"/>
8	Manuals and engine identity card	<input type="checkbox"/>
9	Several small parts (spark plug, screws,...)	<input type="checkbox"/>
10	Hose package for RAVE control unit	<input type="checkbox"/>
11	ECU	<input type="checkbox"/>
12	Carburetor	<input type="checkbox"/>

BRP-Rotax INSTALLATION INSTRUCTION

ENGINE INFORMATION

Engine serial number

The engine serial number is stamped on the clutch side housing-half.

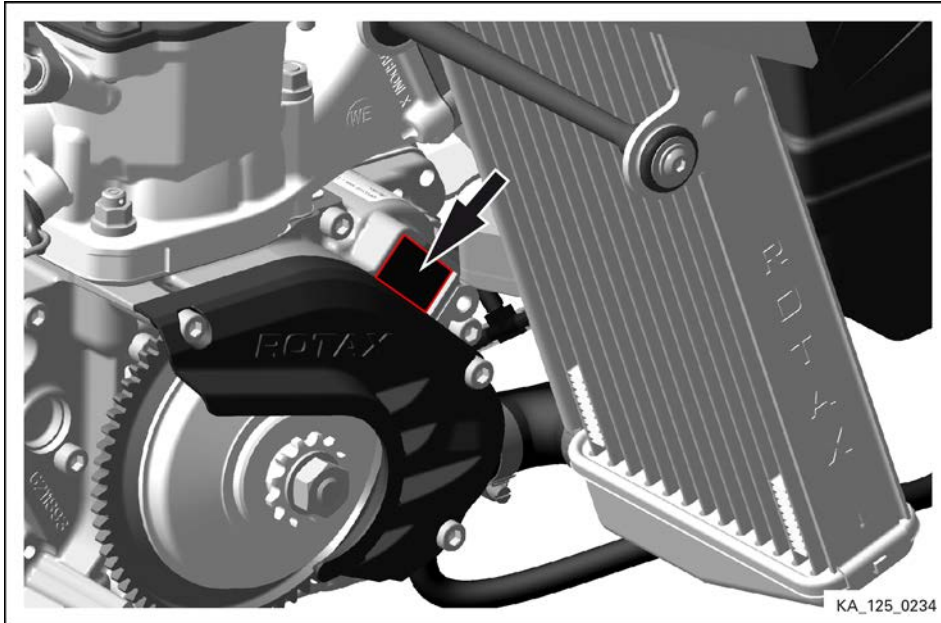

Figure 1.4: Serial number of the engine, TYPICAL

BRP-Rotax
INSTALLATION INSTRUCTION

Gear oil and fuel specifications

See the latest Operators Manual.

Equipment and modifications

Modifications to engine and/or equipment are not allowed.

BRP-Rotax
INSTALLATION INSTRUCTION

NOTES

Notes

Page 8
Edition: October 01 2019

Effectivity: 125 MAX evo, Junior MAX
evo, Mini MAX evo, Micro MAX evo
Edition October 01 2019/Rev. 0

BRP-Rotax
INSTALLATION INSTRUCTION

Chapter: 1
ENGINE INSTALLATION

TOPICS IN THIS CHAPTER

Engine installation to the chassis.....2
Attachment via engine pedestal3

BRP-Rotax INSTALLATION INSTRUCTION

ENGINE INSTALLATION TO THE CHASSIS

Tools required:

- Allen key 8mm
- Ratchet wrench

NOTE

These instructions may differ depending on the type of chassis. They are for general information only

NOTE

Apply abrasive paper between the chassis and the engine brackets to prevent the engine from moving under racing conditions

Step	Procedure
1	Install the upper part of the engine brackets (2) to the engine (1).
2	Place the abrasive tape strips (3) in the area, where you will apply the engine to your chassis.
3	Place the engine onto the frame and pre-install the bottom engine brackets (4) to the engine (1). Make sure not to tighten them up now, so that the engine is still movable onto the frame.
4	Put the engine back as far as possible.
5	Put the chain around the rear axle and fit the chain to the front sprocket first.
6	Fit the chain also to the rear sprocket.
7	Move the engine forward to tighten the chain.
8	If you adjusted the correct chain tension, use the stopper to keep the engine in the correct position.

Step	Procedure
9	Tighten the screws for the engine brackets.
10	Make sure that the rear sprocket and the front sprocket align to each other, use a ruler to check it.

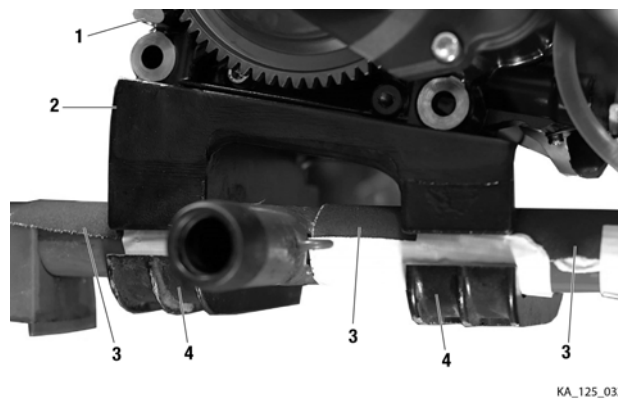

Figure 2.1: Example of Engine installation

- | | |
|------------------------|-------------------------|
| 1 Engine | 2 Upper engine bracket |
| 3 Abrasive tape strips | 4 Bottom engine bracket |

BRP-Rotax
INSTALLATION INSTRUCTION

ATTACHMENT VIA ENGINE
PEDESTAL

When using an engine pedestal for the ROTAX® engine 125 MAX evo/Junior MAX evo/Mini MAX evo/Micro MAX evo, the engine is inclined at 0° to 15° in the driving direction.

Step	Procedure
1	Drill 4 holes (8.5 mm dia / 0.315 in. = drill size) on the coordinates 80 mm x 102 mm / 3.15 in. x 4.016 in. in the top plate of the pedestal suitable for the chassis.

⚠ WARNING

Non-compliance can result in serious injuries or death!

When drilling the holes in the pedestal, pay attention to the advice of the chassis manufacturer.

Step	Procedure
2	Connect pedestal with engine crankcase with 4 screws M8 (min. strength grade 8.8). Tighten screws to 24 Nm / 212 in. lb.

⚠ WARNING

Non-compliance can result in serious injuries or death!

Pay attention to chain alignment as advised by chassis manufacturer.

NOTE

Do not fasten engine on chassis until chain is in position and properly aligned and tensioned.

BRP-Rotax
INSTALLATION INSTRUCTION

NOTES

Notes

Page 4
Edition: October 01 2019

Effectivity: 125 MAX evo, Junior MAX
evo, Mini MAX evo, Micro MAX evo
Edition October 01 2019/Rev. 0

BRP-Rotax
INSTALLATION INSTRUCTION

Chapter: 2
FUEL SYSTEM

TOPICS IN THIS CHAPTER

Installation and connection of the fuel pump.....	2
Installation of the Bowden cable for carburetor control.....	4
Installation and connection of the carburetor.....	6

BRP-Rotax INSTALLATION INSTRUCTION

INSTALLATION AND CONNECTION OF THE FUEL PUMP

Step	Procedure
1	The retaining plate, rubber buffers, fuel pump, fuel hose (with 230 mm and 1800 mm length) is already pre-assembled.

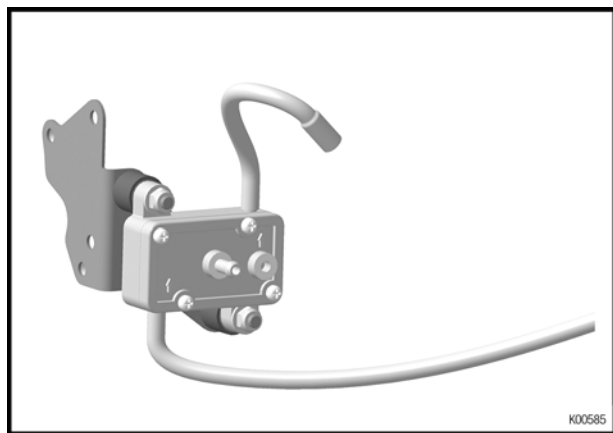

Figure 3.1

Step	Procedure
2	Install the support bracket (pos. 1) with fuel pump on the carburetor socket using 3 screws M6x30 (pos. 2). Tightening torque 6 Nm / 53 lbf in.

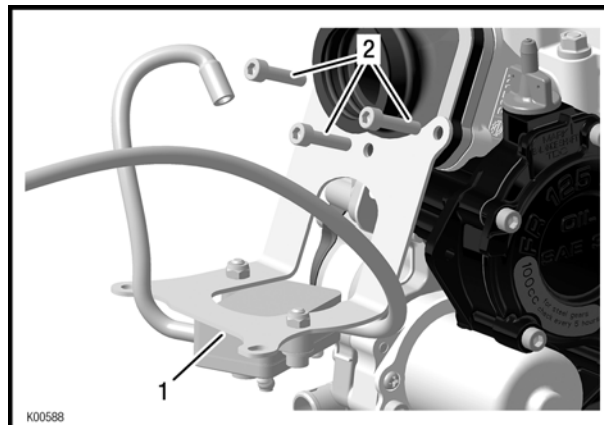

Figure 3.2

- 1 Support bracket 2 Screws M6x30

TIP Facilitate the assembly of fuel hose by slightly widening the hose end with a pair of circlip pliers.

ATTENTION

Fuel hose can be damaged!
Avoid excessive widening of the fuel hose.



Figure 3.3

Step	Procedure
3	The fuel hose with 230 mm length will be connected later to the carburetor, see carburetor installation in section 3.
4	The larger fuel hose (pos. 1) should be connected to the fuel filter (pos. 2) and to the fuel tank.

BRP-Rotax INSTALLATION INSTRUCTION

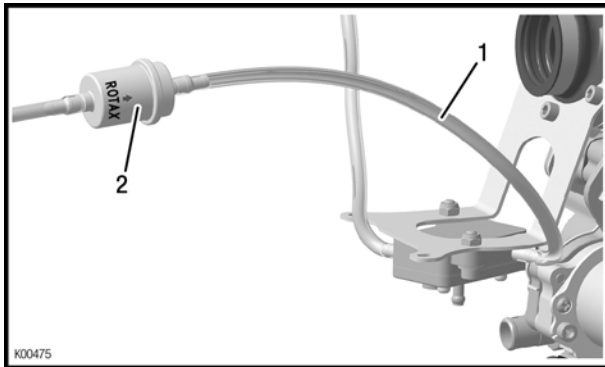

Figure 3.4

1 Large fuel hose 2 Fuel filter

Concerns all engines except 125 MAX evo

For engines without exhaust slide, a direct connection (with vacuum hose) between the gearbox and the fuel pump must be installed.

NOTE

For engines *with* exhaust slide, see chap. 8.

Step	Procedure
5	Cut a 400 mm (15.75 in.) long piece of fuel hose.
6	Secure the vacuum line (pos. 2) on the gearbox housing to prevent disengagement using a tie wrap (pos. 1).

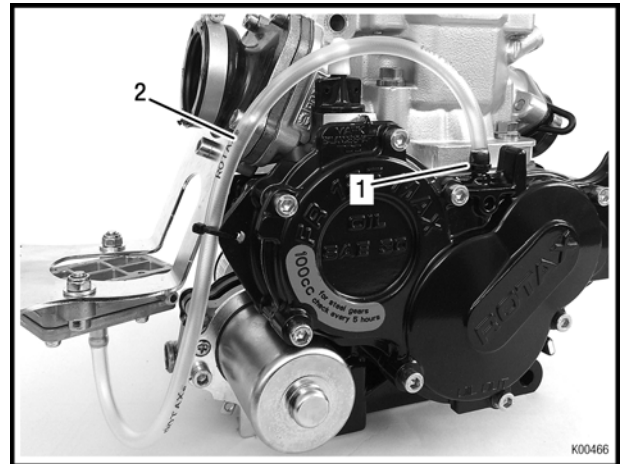

Figure 3.5

Concerns all engines

Step	Procedure
7	Install the connection between the fuel tank and the fuel filter. the length of this line may vary from chassis to chassis.

ATTENTION

Pay attention to the direction of the arrow on the fuel filter.
This must point towards the fuel pump.

ATTENTION

Route the fuel line from the fuel tank to the fuel filter so that it does not touch any moving parts of the track and attach the fuel line onto the top side of the chassis tube.

ATTENTION

The flow in the impulse hose and fuel lines must not be restricted by the use of cable ties.

ATTENTION

The use of an extra fuel filter must not cause further flow resistance in the fuel line between the fuel tank and the fuel pump.

BRP-Rotax INSTALLATION INSTRUCTION

INSTALLATION OF THE BOWDEN CABLE FOR CARBURETOR CONTROL

Tools required:

- Open-end wrench 10 mm

Step	Procedure
1	Carefully remove carburetor cover with rubber ring (pos. 7, 8).

ATTENTION

Reset spring of carb piston presses against carburetor cover and might eject carburetor cover at removal.

Step	Procedure
2	Remove nipple screw (pos. 5) with open-end wrench 10 mm from carburetor piston (pos. 2).
3	Engage nipple of Bowden wire (pos. 9) in nipple screw (pos. 5).
4	Fit nipple screw in carburetor piston and hand tighten with open-end wrench 10 mm.
5	Insert carburetor piston (pos. 2) into carb body with recess of piston towards intake silencer.
6	Pass Bowden wire through compression spring (pos. 6) and through cover with rubber ring (pos. 7, 8) of carburetor.
7	Fit carb cover (pos. 7) on carburetor.
8	Pass Bowden wire through Bowden conduit and through adjustment screw on chassis (throttle pedal).
9	Connect Bowden cable to throttle pedal.

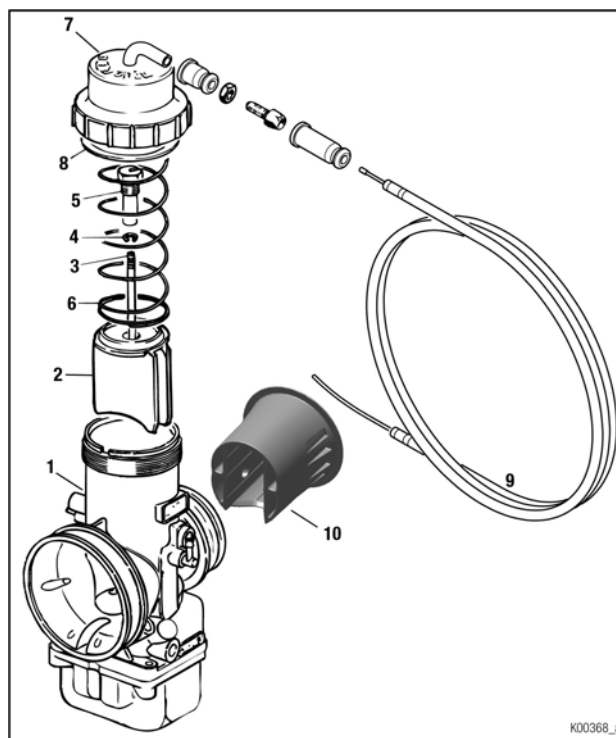

Figure 3.6

- | | |
|------------------|-------------------------------------|
| 1 Carburetor | 2 Carburetor piston |
| 3 Jet needle K57 | 4 Clip |
| 5 Nipple screw | 6 Compression spring |
| 7 Carb cover | 8 Rubber ring |
| 9 Bowden cable | 10 Restrictor (Mini, Micro MAX evo) |

NOTE

Shorten Bowden cable as required.

Step	Procedure
10	Route carburetor Bowden cable on the top side of the chassis tubes and attach with the cable ties supplied. Make sure that the Bowden cable does not touch any moving parts or the track.

BRP-Rotax INSTALLATION INSTRUCTION

WARNING

**Non-compliance can result in serious injuries
or death!**

The carburetor Bowden cable must not be kinked
or restricted as the carburetor piston might get
stuck in full throttle position.

Step	Procedure
11	Set and secure the adjustment screw for Bowden cable on chassis so that the carburetor piston will remain in closed position when throttle pedal is not activated.
12	Set and secure the stop screw for throttle pedal so that, with pedal completely pressed down, the carburetor piston will be in the full open position. The Bowden cable must not be under full tension when the throttle is in fully open position.

BRP-Rotax
INSTALLATION INSTRUCTION

INSTALLATION AND CONNECTION
OF THE CARBURETOR

Tools required:

- Ratchet wrench with socket 7 mm
- Phillips screwdriver

Step	Procedure
1	Fit carburetor (pos. 1) into carburetor socket and secure with hose clamp (pos. 2) in vertical position.
2	Connect the outlet hose of the fuel pump with fuel inlet (pos. 3) on the carburetor.

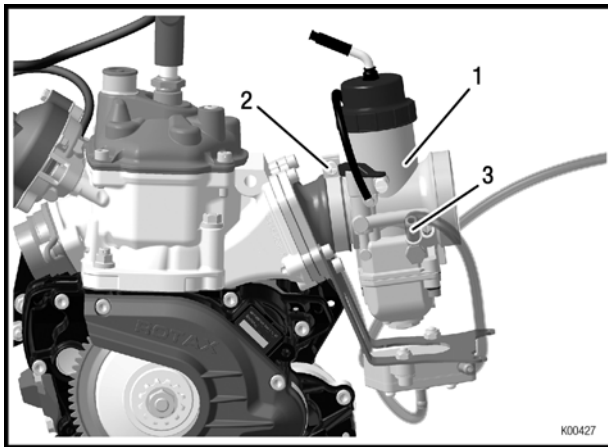

Figure 3.7

- 1 Carburetor 2 Hose clamp
3 Fuel inlet

BRP-Rotax
INSTALLATION INSTRUCTION

Chapter: 3
ELECTRIC SYSTEM

TOPICS IN THIS CHAPTER

Installation of the wiring harness	2
Wiring harness - overview	4
Installation ECU into the battery clamp assy.....	5
Installation of the battery clamp assy.	7

BRP-Rotax INSTALLATION INSTRUCTION

INSTALLATION OF THE WIRING HARNESS

The wiring harness is delivered partly pre-assembled to facilitate the installation. This means that the relay, the multiple function switch and the battery cover are already pre-assembled and wired.

NOTE

The connector assignment is shown on the following pages. Details on the assignment of cables and pins are given in the wiring diagram.

NOTE

Cable lugs may break after repeated bending.

Step	Procedure
1	Place the wiring harness loosely on the chassis.

NOTE

Always start the installation at the engine side to work without tension on the wiring harness.

ATTENTION
Strain relief of the plug connections must be ensured.

NOTE

Compensate excessive length of wiring harness by routing cables in loops.

⚠ WARNING
Non-compliance can result in serious injuries or death!
The wiring harness must not touch moving parts of the track.

NOTE

When unplugging connections on ignition pick up and ignition coil, press the integrated catch first.

NOTE

Disconnect any electrical plug connection only by pulling against the plugs.

Step	Procedure
2	Pre-mount the large cable tie (pos.1) through the two holes provided on the mounting plate (pos. 2).

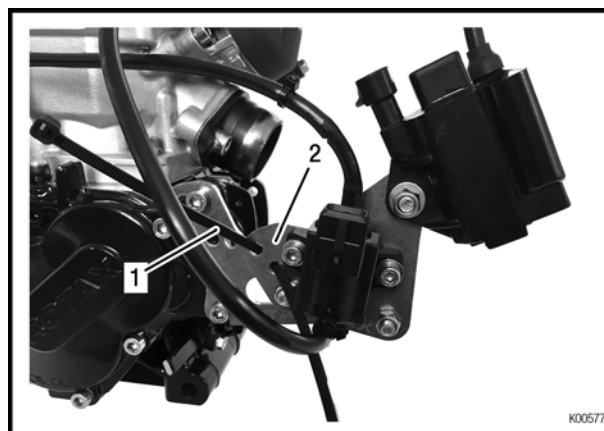

Figure 4.1

Step	Procedure
3	Connect solenoid valve (pos. 1) and ignition coil (pos. 2). Attach both connectors (signed green) (pos. 3) to the two components.

BRP-Rotax INSTALLATION INSTRUCTION

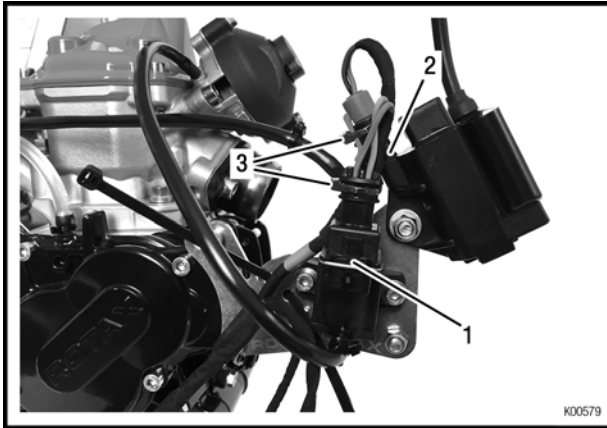

Figure 4.2

Step	Procedure
4	Connect pick-up connector to pick-up sensor (pos. 1). Pay attention to the engagement of the connector.

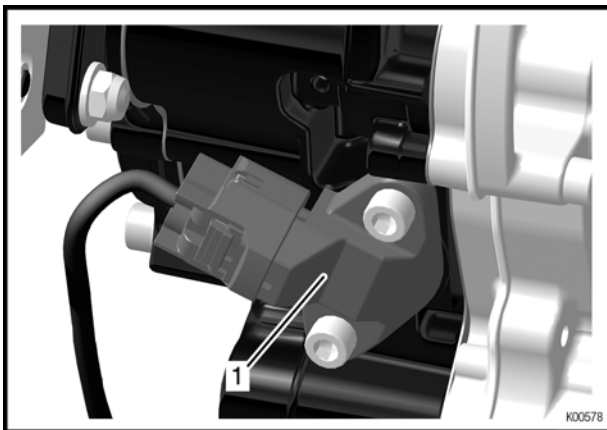

Figure 4.3

Step	Procedure
5	Fix the shift contact cable and the possibly too long cable (pos. 1) of the pick-up sensor (pos. 3) with the pre-mounted tie wrap (pos. 2) onto the mounting plate.

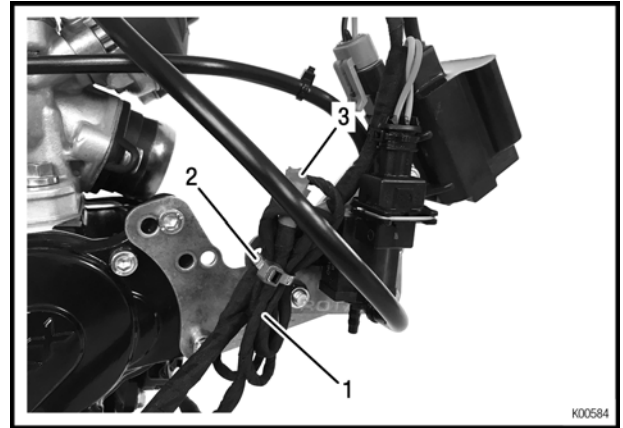

Figure 4.4

NOTE

The shift contact cable must be isolated, because there is no use on non-gear engines.

For engines without exhaust slide only:

In the following figure you see the laying of the wiring harness on engines without exhaust slide. Also you see a dummy plug (part no. 666900) as an option, which is not included in the scope of delivery. It can be secured using tie wraps instead of the solenoid valve.

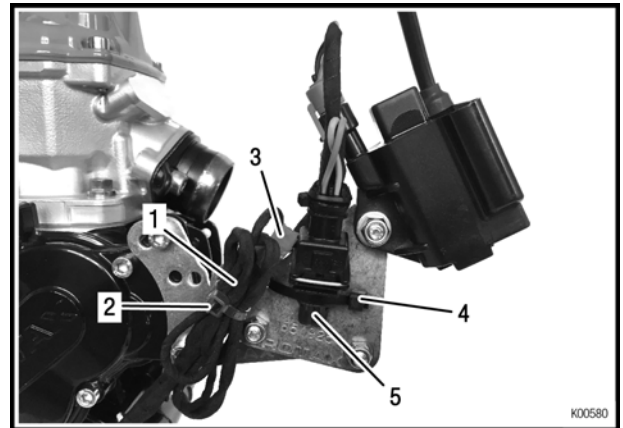

Figure 4.5

Step	Procedure
6	Attach the ignition cable onto the wiring harness.

BRP-Rotax
INSTALLATION INSTRUCTION

WIRING HARNESS - OVERVIEW

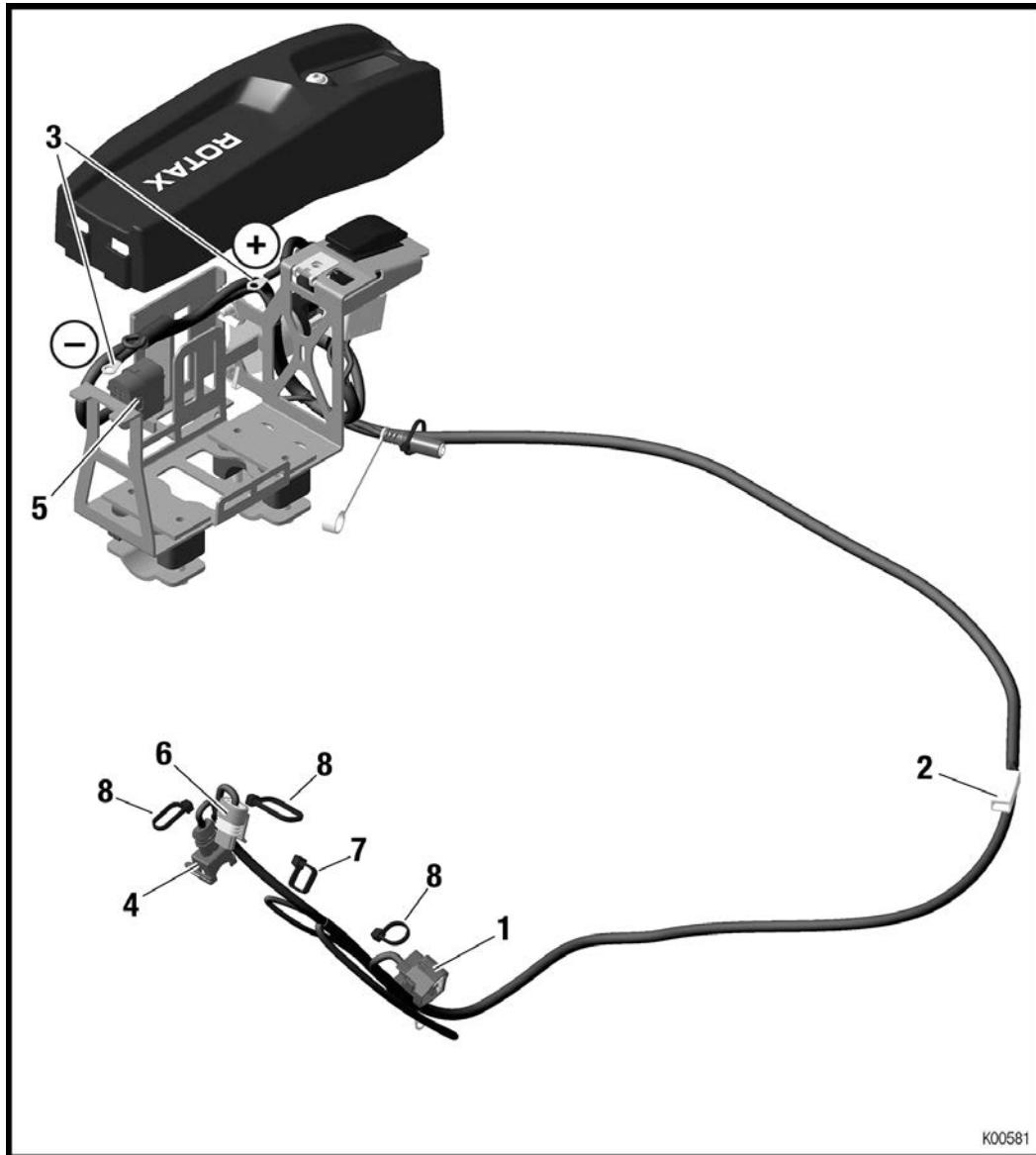

Figure 4.6

- | | |
|---------------------------|--|
| 1 Connector pickup sensor | 2 Connector starter |
| 3 Connector battery | 4 Connector RAVE (only applicable 125 MAX evo) |
| 5 Connector ECU | 6 Connector ignition coil |
| 7 Tie wrap 250x4.8 | 8 Tie wrap 142x3.2 |

BRP-Rotax INSTALLATION INSTRUCTION

INSTALLATION ECU INTO THE BATTERY CLAMP ASSY.

Step	Procedure
1	Prepare rubber pad (consists of two halves) (pos. 1) and the ECU (pos. 2) for installation.

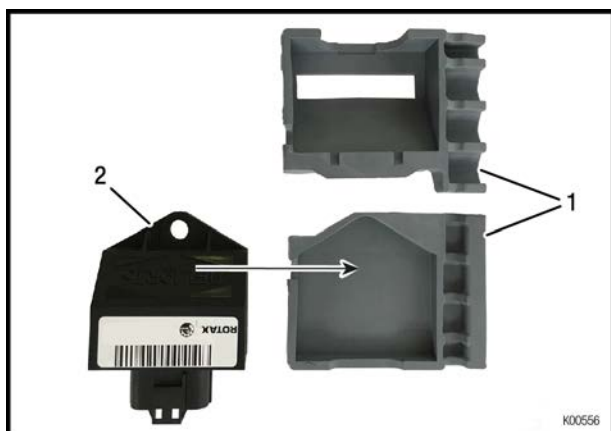

Figure 4.7

1 Rubber pad 2 ECU

Step	Procedure
2	Install the rubber pad (pos. 1) onto the ECU.

TIP Align at the triangular bottom of the ECU. It fits only in one position to the rubber pad.

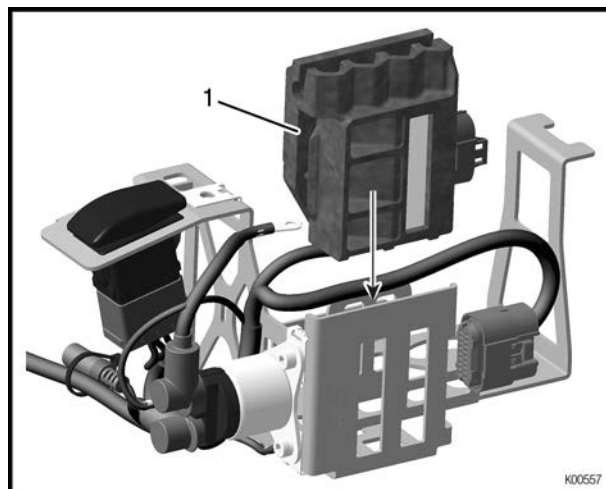

Figure 4.8

1 Rubber pad

Step	Procedure
3	Insert the complete unit into the battery clamp assy..

NOTE

If difficulties at insertion occur, the inside of the battery clamp assy. can be easily bent inward so that the distance increases slightly.

ATTENTION

Make sure that the connection cable has been installed between the two pads.
The connection of the ECU is on the rear side (against the driving direction).

BRP-Rotax INSTALLATION INSTRUCTION

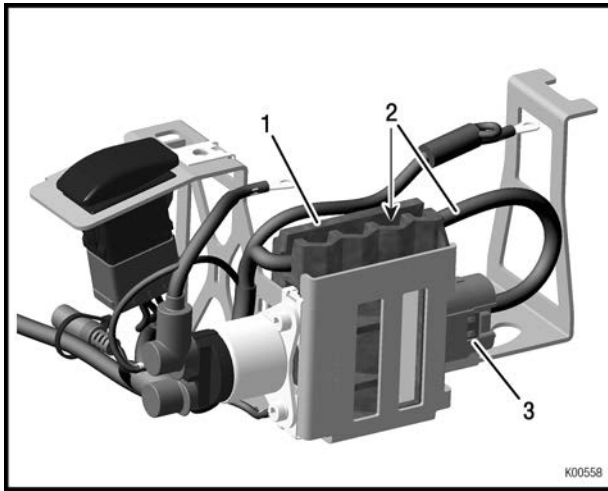

Figure 4.9

- | | | | |
|---|----------------------|---|-------------------------|
| 1 | <i>Rubber pad</i> | 2 | <i>Connection cable</i> |
| 3 | <i>ECU connector</i> | | |

BRP-Rotax INSTALLATION INSTRUCTION

INSTALLATION OF THE BATTERY CLAMP ASSY.

Tools required:

- Allen key 4 mm
- Ratchet wrench with socket 8 mm or Phillips screwdriver

⚠ WARNING

Non-compliance can result in serious injuries or death!

Make absolutely sure to avoid short-circuiting of battery terminals. A short circuit will ruin the battery and could cause an explosion.

Step	Procedure
1	Attach the battery fixture (pos. 5) with the two pipe clamps (pos. 1 – 4) on the left side box beside the driver's seat.

NOTE

The clamps (pos. 2, 3) are designed for chassis tubes of 30 - 32 mm (1.18 – 1.26 in) diameter.

ATTENTION

Risk of clamp fracture!

Do not over tighten the screw of the pipe clamps.

Step	Procedure
2	Install rubber pad (pos. 6) with battery (pos. 7) into the battery holder (pos. 5).
3	Put the battery (pos. 7) into the fixture and install the cover (pos. 8) with pre-assembled wiring harness using the Allen screw with rounded flange head (pos. 9).

TIP The battery fixture (pos. 5) can be fixed with one screw on one side of the clamp (pos. 3).

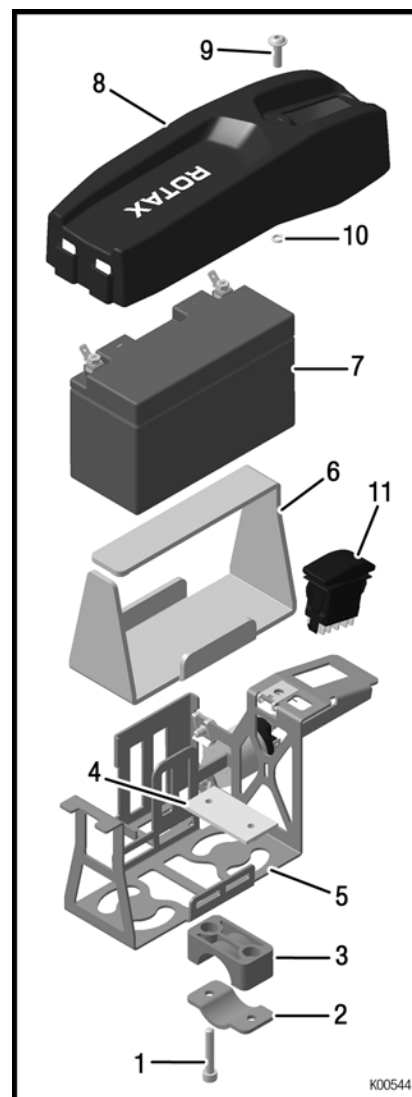

Figure 4.10

- | | |
|-----------------|-----------------------------|
| 1–4 Pipe clamps | 5 Battery fixture |
| 6 Rubber pad | 7 Battery |
| 8 Battery cover | 9 Flange head screw |
| 10 O-ring | 11 Multiple function switch |

BRP-Rotax INSTALLATION INSTRUCTION

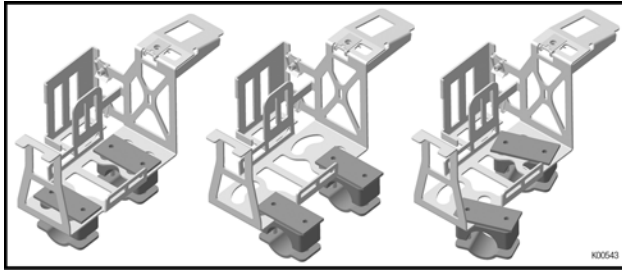

Figure 4.11

NOTE

The battery terminals must point in the direction of the control unit.

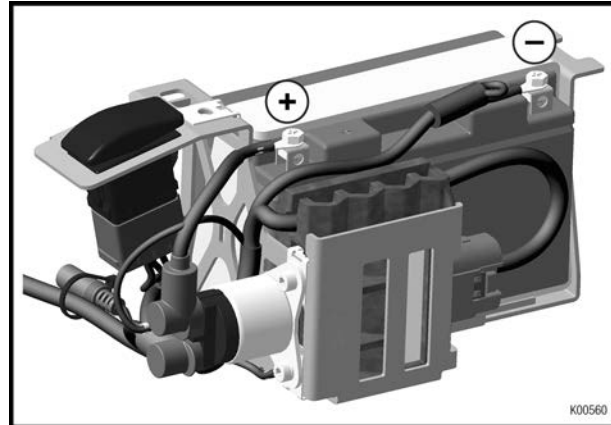

Figure 4.13

Step	Procedure
5	Install the battery cover onto the battery holder.

NOTE

Make sure that the two retaining lugs (pos. 1) are in the notches of the battery cover!

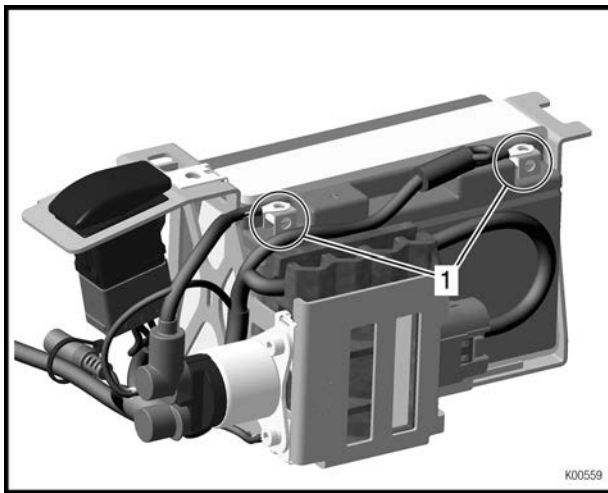

Figure 4.12

1 Battery terminals

Step	Procedure
3	Connect the positive terminal (red) of the battery.
4	Connect the negative terminal (black) of the battery.

Step	Procedure
6	Tighten flange head screw (pos. 2) of the battery cover.

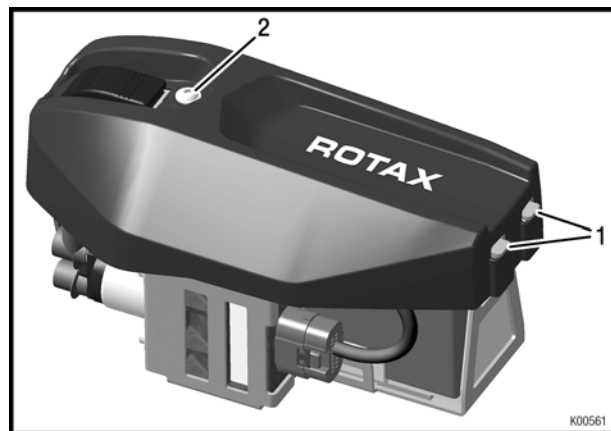

Figure 4.14

1 Retaining lugs

2 Flange head screw

BRP-Rotax
INSTALLATION INSTRUCTION

Chapter: 4
COOLING SYSTEM

TOPICS IN THIS CHAPTER

Cooling system - overview	2
Installation of the radiator	3
Intake silencer	5
Installation of the intake silencer with integrated airfilter	6

BRP-Rotax INSTALLATION INSTRUCTION

COOLING SYSTEM - OVERVIEW

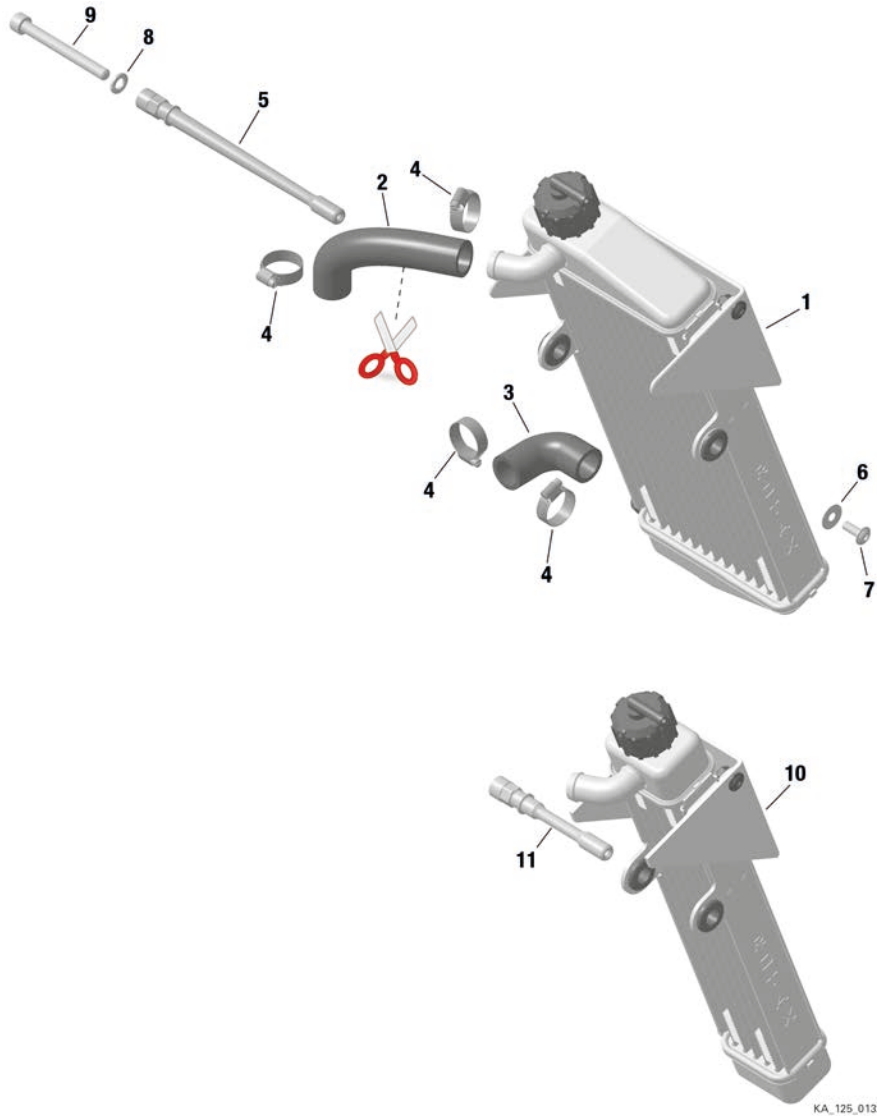

Figure 5.1

- | | | | |
|----|---|----|---|
| 1 | Large radiator | 2 | Upper coolant water hose |
| 3 | Lower coolant water hose | 4 | Clamp 16–25 |
| 5 | Radiator bracket | 6 | Washer |
| 7 | Allen screw with rounded flange head | 8 | Lock washer |
| 9 | Allen screw | 10 | Small radiator (125 Micro MAX evo only) |
| 11 | Radiator bracket (125 Micro MAX evo only) | | |

BRP-Rotax INSTALLATION INSTRUCTION

INSTALLATION OF THE RADIATOR

ATTENTION	
<p>Warrant the best possible engine cooling. Ensure that the air stream covers the complete radiator area.</p>	

Step	Procedure
1	Pre-mount radiator with cooling hoses and radiator support as shown.

NOTE

The large radiator (pos. 1) fits to engine types 125 MAX evo, 125 Junior MAX evo and 125 Mini Max evo.

The small radiator (pos. 2) fits to engine type 125 Micro MAX evo.

The installation of both radiators is similar.

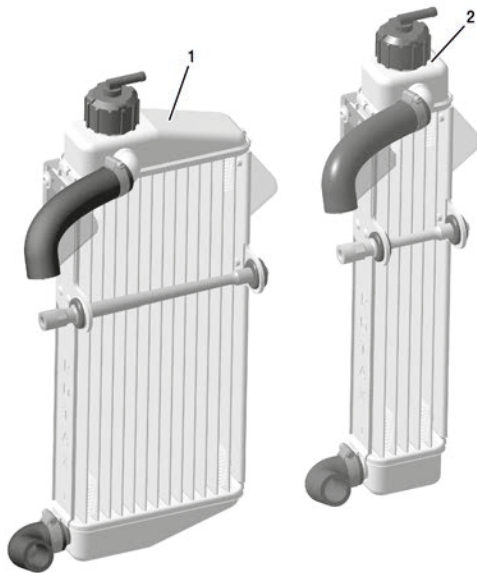

Figure 5.2

Step	Procedure
2	Attach the pre-assembled radiator to the engine with Allen screw M8x75 (pos. 1) and washer (pos. 2).

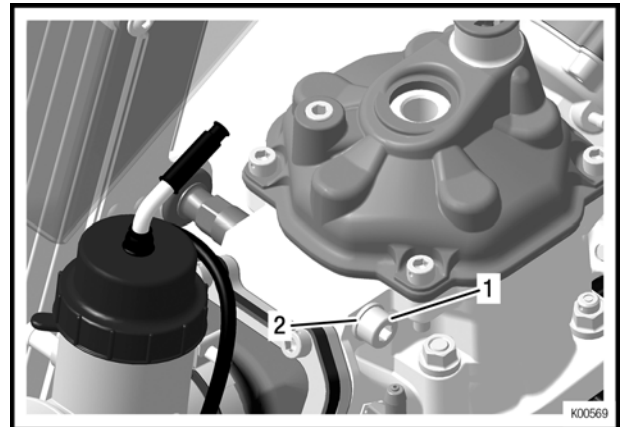

Figure 5.3

- 1 Allen screw M8x75 2 Washer

Step	Procedure
3	Attach the pre-assembled upper coolant hose to the engine using 1 hose clamp (pos. 3).

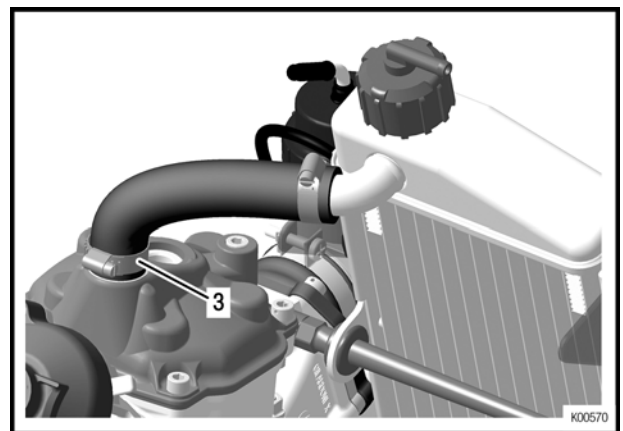

Figure 5.4

- 3 Hose clamp 16–25

Step	Procedure
4	Attach the pre-assembled lower coolant hose to the engine using 1 hose clamp (pos. 4)..

BRP-Rotax INSTALLATION INSTRUCTION

NOTE

The length of the upper and bottom hose is supposed to be different, but equal at delivery. Therefore, cut the bottom hose using scissors or a knife.

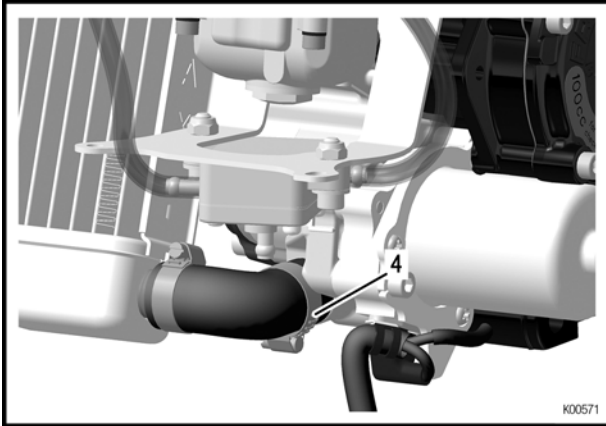

Figure 5.5

4 Hose clamp 16–25

BRP-Rotax
INSTALLATION INSTRUCTION

INTAKE SILENCER

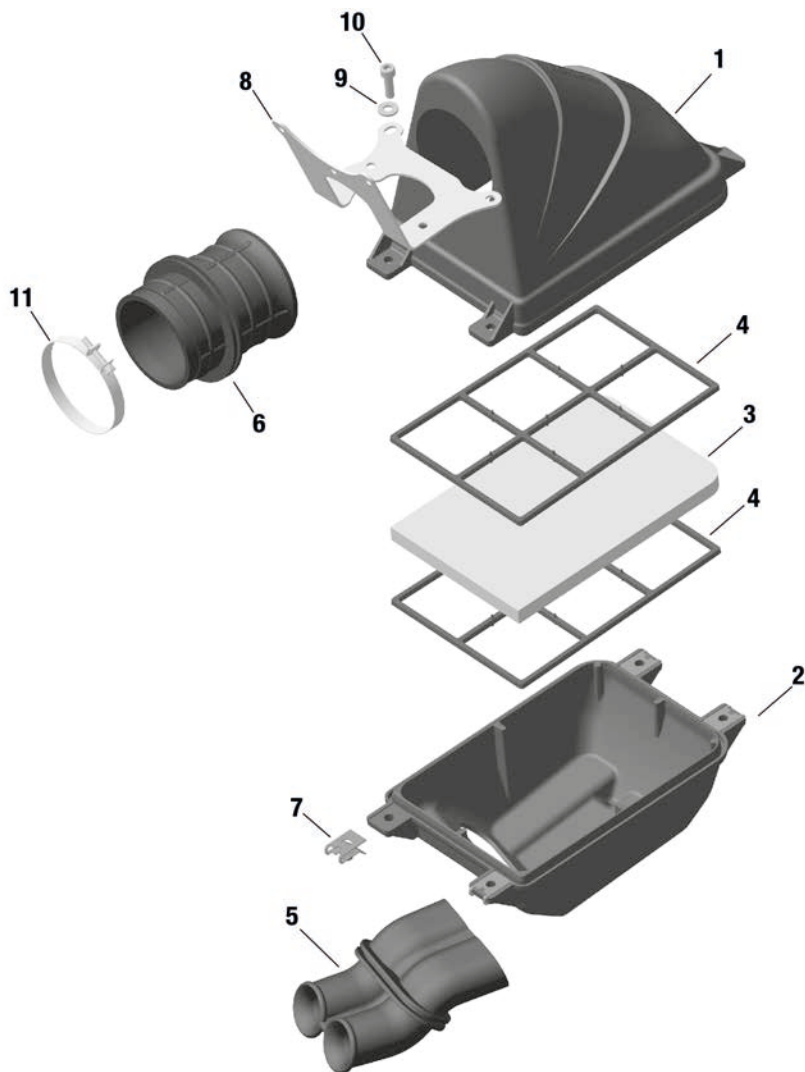

Figure 5.6

- | | |
|-----------------------------|--------------------------------|
| 1 Intake silencer case, top | 2 Intake silencer case, bottom |
| 3 Filter element | 4 Holder for filter element |
| 5 Intake silencer tube | 6 Carburetor socket |
| 7 Lock nut M6 | 8 Support bracket |
| 9 Washer 6.4 | 10 Allen screw M6x20 |
| 11 Clamp 50-70 | |

BRP-Rotax
INSTALLATION INSTRUCTION

**INSTALLATION OF THE INTAKE
SILENCER WITH INTEGRATED
AIRFILTER**

Step	Procedure
1	Install the rubber intake pipe (pos. 5) in a vertical position into the bottom half (pos. 2) of the intake silencer so that the rounded intake openings point outwards.
2	Fit the carburetor socket (pos. 6) into the top half of the intake silencer case (pos. 1) so that the arrow on the socket points towards the carburetor.
3	Install the filter element (pos. 3) with holders (pos. 4) into the bottom half of intake silencer (pos. 2).
4	Assemble bottom half of intake silencer case (pos. 2) with top half (pos. 1) as shown in the following figure. Make sure that the locking is inter-locked properly.
5	Attach the intake silencer with the supplied hose clamp (pos. 11) to the carburetor.

NOTE

The carburetor socket (pos. 6) is asymmetrical and can be turned so that the best possible position between carburetor and intake silencer can be achieved.

Step	Procedure
6	Attach the intake silencer on the support bracket (pos. 8) using 2 Allen screws M6x20 (pos. 10) with washers (pos. 9) and nuts (pos. 7).

BRP-Rotax
INSTALLATION INSTRUCTION

Chapter: 5
EXHAUST SYSTEM

TOPICS IN THIS CHAPTER

Installation of the exhaust system4

BRP-Rotax

INSTALLATION INSTRUCTION

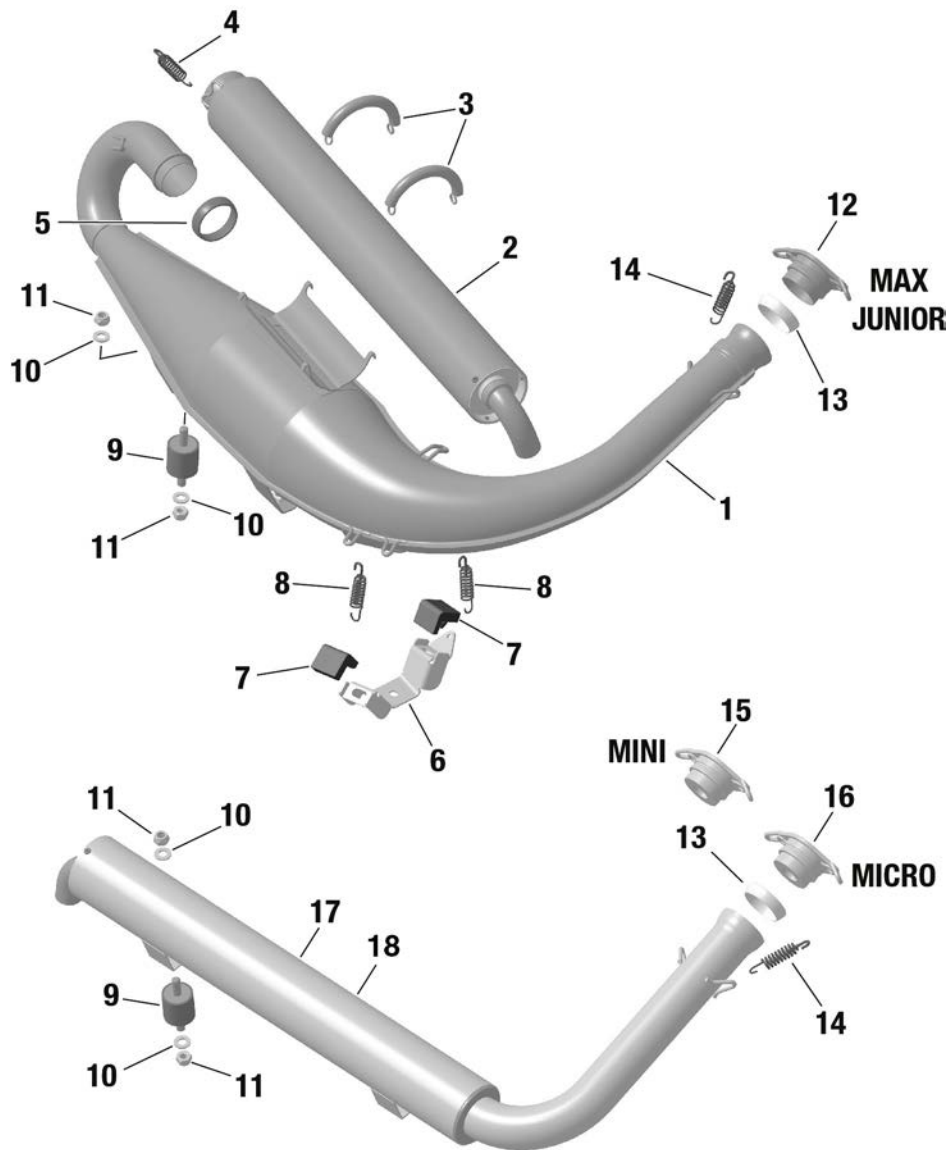

KA_125_0131_a

Figure 6.1

- | | |
|---|---|
| <p>1 Exhaust system (125 MAX evo, 125 Junior MAX evo, 125 MINI MAX evo)</p> <p>3 Tension spring</p> <p>5 Exhaust gasket</p> <p>7 Rubber buffer</p> <p>9 Rubber buffer</p> | <p>2 Silencer assy.</p> <p>4 Spring stainless</p> <p>6 Retaining plate</p> <p>8 Spring stainless</p> <p>10 Washer 8.4</p> |
|---|---|

BRP-Rotax

INSTALLATION INSTRUCTION

- | | | | |
|----|---|----|--|
| 11 | Lock nut M8 | 12 | Exhaust socket assy. (125 MAX evo, 125 Junior MAX evo) |
| 13 | Exhaust gasket | 14 | Spring stainless |
| 15 | Exhaust socket assy. (125 Mini MAX evo) | 16 | Exhaust socket assy. (125 Micro MAX evo) |
| 17 | Exhaust system (125 Micro MAX evo) | 18 | Exhaust system (125 Mini MAX evo), similar to Micro MAX evo but not the same |

BRP-Rotax

INSTALLATION INSTRUCTION

INSTALLATION OF THE EXHAUST SYSTEM

Tools required:

- Open-end wrench 13 mm
- Spring hook

NOTE

On the underside of the exhaust system, two different mounting mechanisms are provided. At the front, the assembly is carried out with rubber buffers (pos. 7) between the retaining plate (pos. 6) and the exhaust system and attached by extension springs (pos. 8). At the rear, the exhaust system is mounted directly using a rubber mount M8 (pos. 9).

ATTENTION

A rigid suspension of the exhaust system could result in fractures in the exhaust system.

Step	Procedure
1	Attach the heat-resistant rubber mount (pos. 9) to the two support lugs on the underside of the tuned exhaust.
2	Arrange the chassis-specific supports so that the exhaust system follows the straightest possible course from the exhaust socket on the cylinder to the muffler.
3	The gasket (pos. 13) is the only sealing between engine and the exhaust system. Additional heat-resistant LOC-TITE is not necessary anymore.

NOTE

All engine types have the same gaskets.

NOTE

A leakage in the exhaust system may lead to performance loss.

Step	Procedure
4	Secure the exhaust system on the ball joint using the two supplied exhaust springs (pos. 14).

NOTE

For easier installation use the special tool "Spring hook" part no. 251680.

ATTENTION

Do not over-stress the springs when fitting them.

Step	Procedure
5	Attach the exhaust system on the chassis supports such that the sealing of the ball joint between cylinder and exhaust system will not be impaired.

Exhaust socket dimensions:

Engine type	Exhaust socket ø
125 MAX evo	Ø 37 mm / 1.46 in.
125 Junior MAX evo	Ø 37 mm / 1.46 in.
125 Mini MAX evo	Ø 20 mm / 0.79 in.
125 Mini MAX evo MY20	Ø 22 mm / 0.87 in.
125 Micro MAX evo	Ø 18 mm / 0.71 in.

BRP-Rotax
INSTALLATION INSTRUCTION

Chapter: 6
INSTALLATION OF THE ACCESSORIES

TOPICS IN THIS CHAPTER

Installation of mounting plate	2
Fitting of the spark plug.....	3
Installation and connection of the RAVE control unit	4

BRP-Rotax INSTALLATION INSTRUCTION

INSTALLATION OF MOUNTING PLATE

NOTE

The retaining plate, the mounting plate, the solenoid valve (except engines without exhaust slide) and the ignition coil are already pre-assembled.



Figure 7.1

Variant 1: Engines without exhaust slide

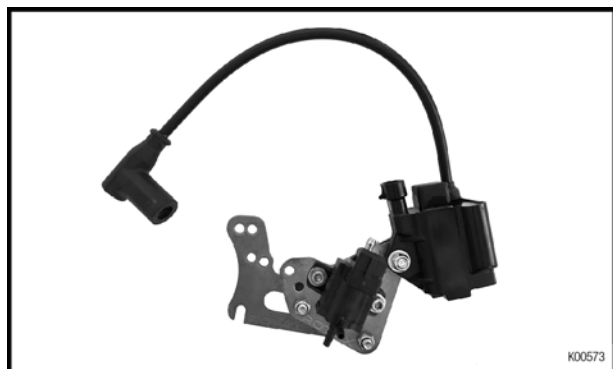

Figure 7.2

Variant 2: Engines with exhaust slide

Step	Procedure
1	Install mounting plate to crankshaft housing (pos. 4) using 2 Allen screws M6x20 (pos. 1), washers (pos. 2) and lock nuts M6 (pos. 3).

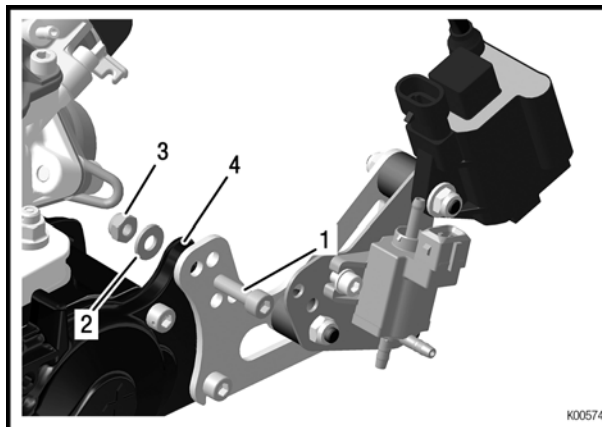

Figure 7.3

- 1 Allen screws M6x20
- 2 Washer 6.4
- 3 Lock nut M6
- 4 Crankshaft housing

NOTE

The position of the mounting plate may vary (depending on the engine type and position of the seat stay).

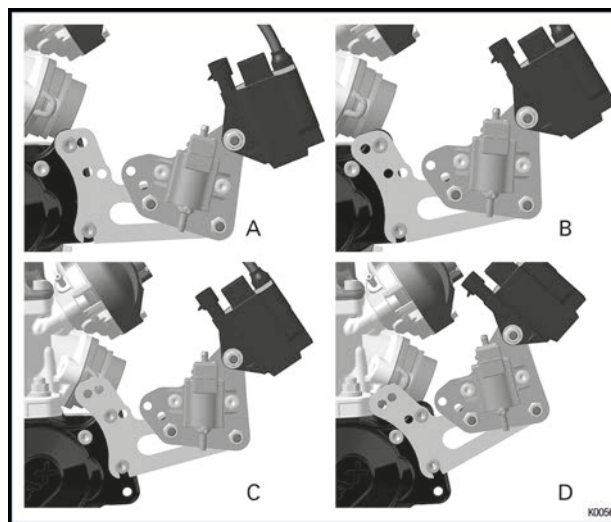

Figure 7.4

Position of the mounting plate

BRP-Rotax INSTALLATION INSTRUCTION

FITTING OF THE SPARK PLUG

The engine will be supplied with a spark plug.

Tools required:

- Feeler gauge
- Socket 21 mm
- Torque wrench

Step	Procedure
1	Remove the transport plug from the cylinder head.
2	Check electrode gap of spark plug. Adjust as required.

NOTE

Check technical regulations to assure conformity when setting the electrode gap.

Step	Procedure
3	Fit supplied spark plug (pos. 1) and tighten 25 Nm (221 lbf in) to 27 Nm (239 lbf in).
4	Install the spark plug connector (pos. 2), ensure correct engagement.

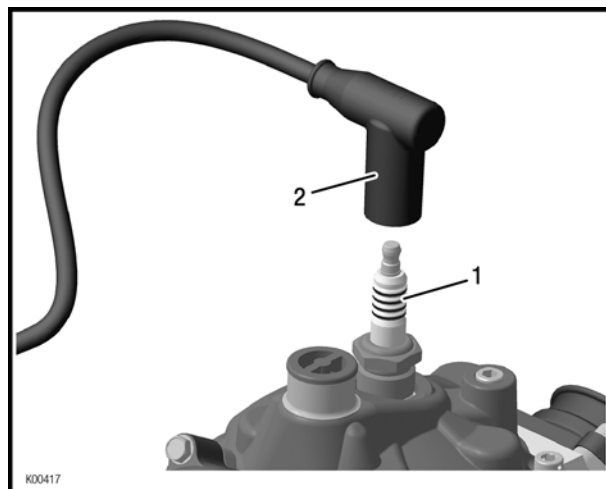

Figure 7.5

1 Spark plug

2 Spark plug connector

BRP-Rotax INSTALLATION INSTRUCTION

INSTALLATION AND CONNECTION OF THE RAVE CONTROL UNIT

NOTE

The hose package of the RAVE control is already pre-assembled.

NOTE

The impulse restrictor is offered optionally.

Step	Procedure
1	Insert impulse nozzle (pos. 6) about 25 mm into the 420 mm pressure line (pos. 7) using an Allen key SW4. Pay attention to the mounting direction! It also works without an impulse nozzle, this only serves to choke the opening of the exhaust valve.

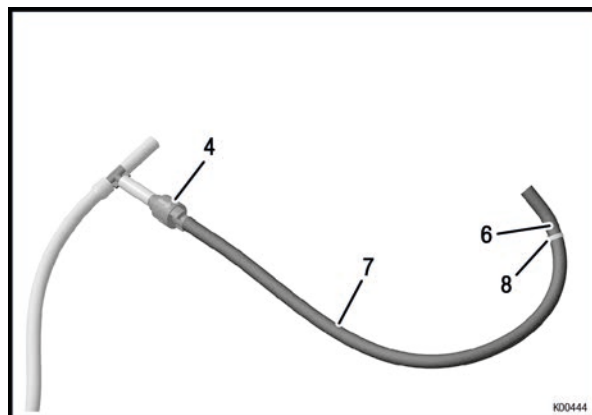

Figure 7.7

- 4 Check valve
- 6 Impulse nozzle
- 7 Pressure line
- 8 Tie wrap small

Step	Procedure
2	Attach the end of the T-fitting (pos. 1) to the bottom of the fuel pump (pos. 2).

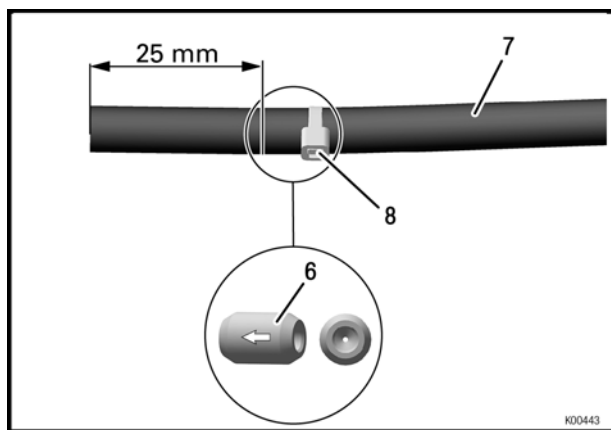

Figure 7.6

- 6 Impulse nozzle
- 7 Pressure line
- 8 Tie wrap small

NOTE

In order to prevent the displacement of the impulse nozzle (pos. 6), a small cable tie (pos. 8) should be attached directly afterwards to the pressure line. Do not tie up the pressure line completely!

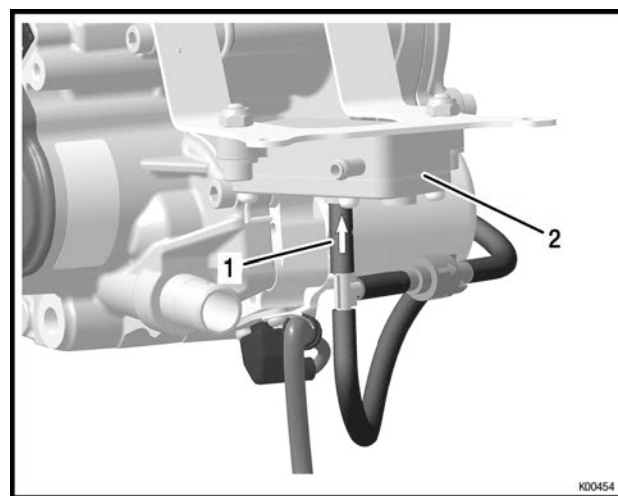

Figure 7.8

- 1 T-fitting
- 2 Fuel pump

BRP-Rotax INSTALLATION INSTRUCTION

Step	Procedure
3	Attach the fuel line (pos. 1) to the impulse nipple on the engine housing and secure the line with tie wrap (small) (pos. 2).

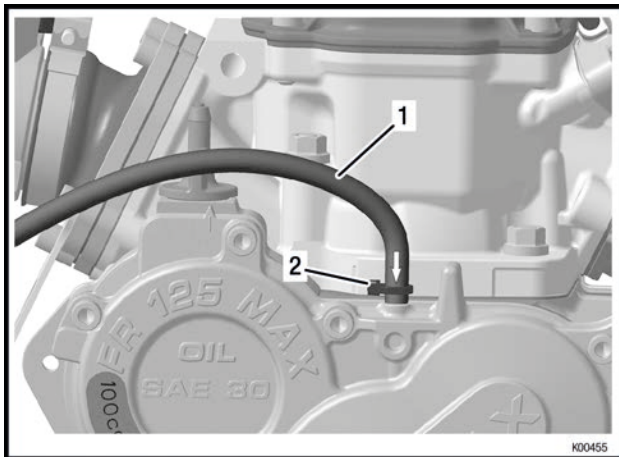

Figure 7.9

- 1 Fuel line 2 Tie wrap (small)

Step	Procedure
4	Attach the black hose of the hose package (pos. 1) to the metal connector (pos. 2) of the magnetic valve.

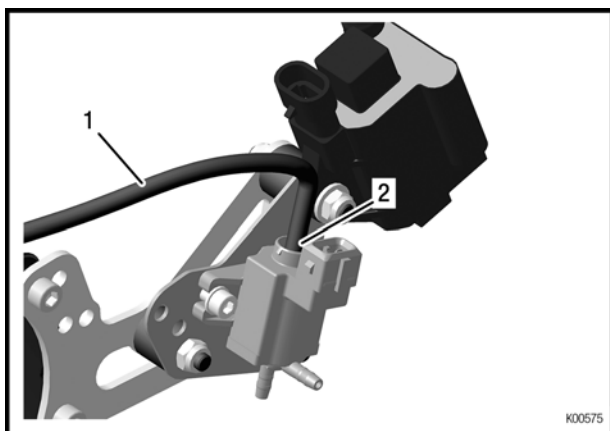

Figure 7.10

- 1 Hose package 2 Metal connector

Step	Procedure
5	Fix another tie wrap (pos. 1) at the fixing point (bore) on the engine housing. Secure both lines with tie wrap (pos. 3), ensuring that the black hose (pos. 2) is on top.

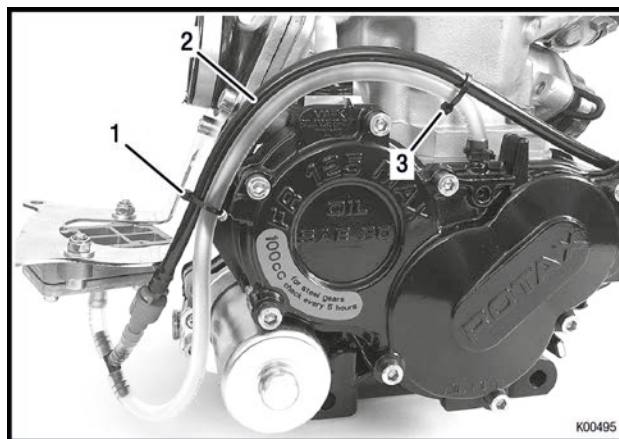

Figure 7.11

- 1 Tie wrap 2 Black hose
3 Tie wrap

Step	Procedure
6	Attach the 280 mm pressure line (pos. 1) to the exhaust valve (pos. 2) and to the magnetic valve (pos. 3). Secure the pressure line on the magnetic valve with a tie wrap (pos. 4).

BRP-Rotax INSTALLATION INSTRUCTION

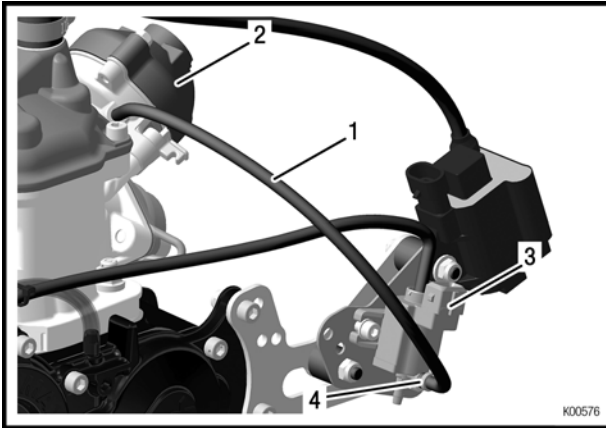

Figure 7.12

- | | | | |
|---|----------------|---|---------------|
| 1 | Pressure line | 2 | Exhaust valve |
| 3 | Magnetic valve | 4 | Tie wrap |

BRP-Rotax
INSTALLATION INSTRUCTION

Chapter: 7
FINISHING WORK

TOPICS IN THIS CHAPTER

Check oil level in gear box.....	2
Fitting of the drive chain.....	3
Venting of the gear compartment	5

NOTE

NOTE

To warrant engine operation within temperature limits of the coolant, a temperature sensor for observation of the coolant temperature is required.

NOTE

Refer to Operators Manual for operating limits.

BRP-Rotax INSTALLATION INSTRUCTION

CHECK OIL LEVEL IN GEAR BOX

The gear box is already filled with the appropriate amount of oil 100 CC (0.026 gal.) by the engine manufacturer. However, before the engine is installed in the frame, the oil level must be verified or replenished.

Step	Procedure
1	Place engine on a horizontal surface and/or assembling trestle.

NOTE

To measure the oil level exactly, drain the gear oil and determine it using a measuring cup.

Step	Procedure
2	Loosen Allen screw (pos. 1) with gasket ring (pos. 2) and absorb the leaking oil in a measuring cup. If necessary, remove the air vent screw (pos. 3) to ensure a better oil drain.
3	Determine the gear oil using the measuring cup.

NOTE

Oil capacity at new filling is 100 cc (0.026 gal).

NOTE

Specification of gear oil: engine oil SAE 15W-40.

Step	Procedure
4	Tighten the Allen screw (pos. 1) with new gasket ring (pos. 2) to 10 Nm.
5	Replenish new gear oil in the air vent hole.
6	Hand-tighten the air vent screw (pos. 3).

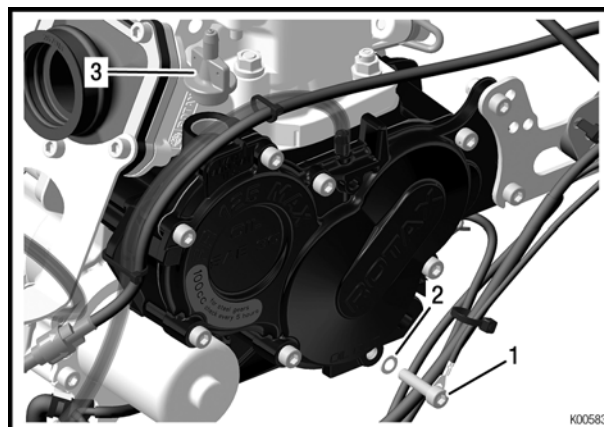

Figure 8.1

- 1 Allen screw
- 2 Gasket ring
- 3 Air vent screw

BRP-Rotax

INSTALLATION INSTRUCTION

FITTING OF THE DRIVE CHAIN

The required length of the drive chain depends on chassis and transmission ratio and the chain is therefore not included in the engine's scope of supply.

ATTENTION

BRP-Rotax recommends O-ring drive chains by ROTAX Premium.

Step	Procedure
1	Use a chain with the length corresponding to the selected transmission ratio of dimension 7.75 x 4.6 x 4.5.
2	Place the chain on the sprocket on the clutch and on the sprocket on rear axle.
3	Verify chain alignment between front and rear chain sprocket with a straight edge. Correct as required by shifting sprocket adapter along rear axle.

⚠ WARNING

Non-compliance can result in serious injuries or death!

Pay attention to chain alignment as advised by chassis manufacturer.

Step	Procedure
4	Establish required chain tension (Sag = +/- 5 mm / +/- 0.20 in.) by shifting the engine. NOTE <i>Use the engine stop screw to tension the chain.</i>
5	Fasten engine on the chassis.

⚠ WARNING

Non-compliance can result in serious injuries or death!

Besides the engine-specific installation advice, also take note of information from the respective chassis manufacturer.

⚠ WARNING

Non-compliance can result in serious injuries or death!

This cover serves merely as splash protection against the grease on the drive chain, but is no protection against contact with the moving parts of the centrifugal clutch and the drive train!

⚠ WARNING

Non-compliance can result in serious injuries or death!

During kart operation, beware of any contact of body or clothing with moving parts of the kart (drive chain, rear axle and wheels). Risk of injury.

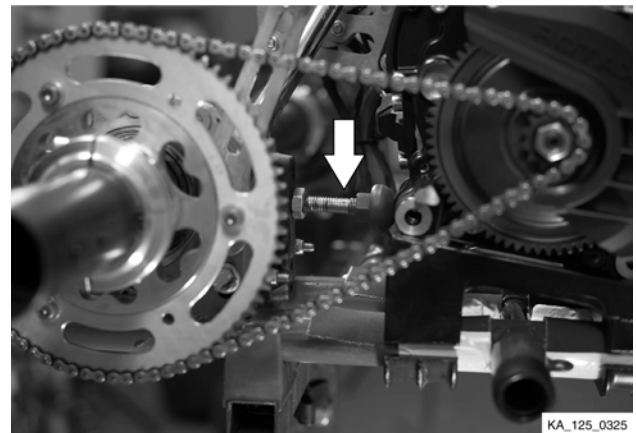

Figure 8.2: Chain tensioner

BRP-Rotax INSTALLATION INSTRUCTION



Figure 8.3: Engine alignment

BRP-Rotax
INSTALLATION INSTRUCTION

VENTING OF THE GEAR COMPARTMENT

Step	Procedure
1	Remove cap from the venting screw.
2	Establish a connection between the venting screw and a collecting reservoir using a piece of the supplied fuel hose of an appropriate length.

NOTE

The venting hose must not reach all the way to the bottom of the collecting reservoir.

ATTENTION

Do not attach the venting hose on the bottom of the collecting reservoir, if only one reservoir is in use.

Run-in Procedure

⚠ WARNING

Non-compliance can result in serious injuries or death!

Running in has to be done with a "long" gear ratio and a rich main jet (2 sizes bigger than the recommended main jet size based on altitude and temperature - see operators manual) as follows:

ATTENTION

For the first 10 liters of fuel use a mixing ratio of 1:33 (=3% or 0,3 liter oil per 10 liters fuel).

NOTE

BRP - Powertrain recommends to use XPS Kart -Tec oil.

Step	Procedure
1	15 min. up to 10.000 rpm 15 min. up to 12.000 rpm 15 min. full load
2	Reduce the main jet size step by step (e.g. 172 - 170 - 168 ...)

NOTE

Make sure that the coolant temperature reaches a minimum of 55°C (130 °F).

At cold ambient temperature radiator needs to get partly covered by tape.

BRP-Rotax
INSTALLATION INSTRUCTION

NOTES

Notes

Page 6
Edition: October 01 2019

Effectivity: 125 MAX evo, Junior MAX
evo, Mini MAX evo, Micro MAX evo
Edition October 01 2019/Rev. 0

BRP-Rotax
INSTALLATION INSTRUCTION

Index

B

Battery, installation7
Bowden cable, installation.....4

C

Carburetor, connection6
Carburetor, installation.....6
Cooling system1
Cooling system overview2

D

Drive chain, fitting.....3

E

ECU, Installation5
Electric system.....1
Engine information3
Engine installation to the chassis2
Engine, attachment3
Exhaust system1
Exhaust system, installation4

F

Finishing work.....1
Fuel pump, installation.....2
Fuel system, installation1

I

Intake silencer5
Intake silencer, installation6
INTRO1

M

Mounting plate, installation.....2

O

Oil level, check in gear box2

R

Radiator, installation3
RAVE control unit, installation4
Run-in procedure5

S

Spark plug, fitting3

U

Unboxing.....1

V

Venting of the gear compartment.....5

W

Wiring harness.....4
Wiring harness, installation2

Operator's Manual

Table of Content

Chapter	INTRO – GENERAL INFORMATION
Chapter	1 – Technical Description
Chapter	2 – Engine
Chapter	3 – Engine calibration
Chapter	4 – Engine operation
Chapter	5 – Preservation and transport

BRP-Rotax
Operators Manual

NOTES

BRP-Rotax
Operators Manual

Chapter: INTRO
GENERAL INFORMATION

Preface

Before operating the engine, read the Operators Manual carefully.
If any passages of the Manual are not clearly understood or if you have questions, please contact an authorized Distribution or Service Center for ROTAX®-kart engines.
This document and all technical data and procedures therein are property of BRP-Rotax GmbH & Co KG and based on the state of knowledge at the time of publication The Manual has been drawn up to the best of our knowledge. However, excluding any liability. We reserve all rights including technical modification and possibility of errors. Reprinting, translation or copies in whole or in part, are authorized only after written permission by BRP-Rotax GmbH & Co KG.
BRP-Rotax GmbH & Co KG reserves the right at any time to discontinue or change specifications, prices, designs, features, models or equipment without incurring obligation. Engine performance may vary depending on, among other things, general conditions, ambient temperature and altitude.

Contents

This Operators Manual contains instructions about how to operate the ROTAX®-Engine Type 125 MAX evo, 125 Junior MAX evo, 125 Mini MAX evo and 125 Micro MAX evo.

Symbols used

This Manual uses the following symbols to emphasize particular information. This information is important and must be observed.

⚠ WARNING
Identifies an instruction, which if not followed may cause injury or endanger the life of the driver, mechanic or third party.

ATTENTION
Denotes an instruction which if not followed may severely damage the engine. Noncompliance might lead to health hazards under certain conditions.

<u>ENVIRONMENTAL NOTE</u>
Environmental notes give you tips on environmental protection.

NOTE

Indicates supplementary information which may be needed to fully complete or understand an instruction.

✓ Denotes a checking operation

TIP This information gives you additional advice and tips

BRP-Rotax
Operators Manual

NOTES

Chapter: 1
TECHNICAL DESCRIPTION

TOPICS IN THIS CHAPTER

Design of the ROTAX engine types 125 MAX evo, Junior MAX evo, Mini MAX evo and Micro MAX

evo	2
General	2
Cooling circuit	2
Balance shaft	2
Ignition unit	2
Electric starter	2
Electro pneumatically exhaust timing control (125 MAX only)	3
Intake silencer	3
Exhaust system	3
Fuel pump	3
Carburetor	3
Centrifugal clutch	4

DESIGN OF THE ROTAX ENGINE TYPES 125 MAX EVO, JUNIOR MAX EVO, MINI MAX EVO AND MICRO MAX EVO

GENERAL

The Rotax 125 MAX evo engine is a single cylinder two stroke engine with reed valve controlled inlet and 125 cm³ displacement. Mixture lubrication is achieved by adding oil to the gasoline in a specified mixing ratio.

COOLING CIRCUIT

The coolant is pumped from the radiator to the water pump which is driven by the clutch shaft. The water pump conveys the coolant through cylinder and the cylinder head back to the radiator.

The cooling circuit is equipped with a thermostat (opening point 45 °C / 113 °F). It assures that the engine reaches its operating temperature quickly and keeps it at a relatively constant level.

The thermostat is integrated in the cylinder head cover.

BALANCE SHAFT

The balance shaft rotates counter-wise to the crankshaft to reduce engine vibration.

IGNITION UNIT

The control of the ignition system is exercised by the ECU (Engine Control Unit). To calculate the ignition timing, an engine speed sensor is needed, which is installed on the bottom of the engine housing. There is no manual adjustment of the ignition system necessary and/or possible.

Even if the engine is stopped, the ignition system consumes current. After use, always set the combination switch to position "OFF", to avoid deep discharge of the battery.

ELECTRIC STARTER

By pressing the "START" button, the circuit between the battery and the electric starter will be closed by a relay. The electric starter drives the starter gear on the crankshaft via an intermediate gear with free wheeling, until the engine starts to run. An automatic switch re-set from "START" to "ON" is integrated.

ELECTRO PNEUMATICALLY EXHAUST TIMING CONTROL (125 MAX ONLY)

The engine type 125 MAX evo is equipped with an electro-pneumatic exhaust control. The E-RAVE (Electronic ROTAX Adjustable Variable Exhaust) system is controlled by an electro-pneumatic valve via the ECU. The vacuum required is provided by the engine crankcase.

If the engine is running at idle speed or below the opening point of the E-RAVE system (between approximately 8000-9000 rpm) the exhaust valve is closed. With the engine running, it closes or opens the electro-pneumatic valve of the exhaust depending on the speed and, therefore it provides optimum performance characteristics.

INTAKE SILENCER

The intake silencer incorporates an air filter to clean the intake air. The intake silencer has been designed for optimum reduction of air intake noise level and represents a tuned system with the engine.

The air filter consists of several layers and has been optimized in the area of air passage and filter to work more effectively. If soiled or during engine maintenance work, clean the filter with biodegradable products.

EXHAUST SYSTEM

The exhaust system is designed as resonance system with an after-muffler and represents a tuned system with engine.

FUEL PUMP

The fuel pump is actuated by the pulsating pressure changes in the crankcase and the pump transfers the fuel from the fuel tank to the carburetor.
An inline fuel filter (between fuel tank and fuel pump) keeps foreign particles from entering the fuel pump or the carburetor, respectively.

CARBURETOR

The carburetor (DELL'ORTO VHSB 34) is a slide type carburetor with float system. The standard main jet is suitable for almost all operating conditions. For extreme operating conditions, the main jet size must be adjusted to the actual conditions according to this manual.

BRP-Rotax

Operators Manual

CENTRIFUGAL CLUTCH

The engine is equipped with a centrifugal clutch operating in an oil bath. This clutch separates the engine from the gearbox at less than 2.500 rpm. Only at an engine speed of approx. 4.000 rpm. the centrifugal clutch is completely engaged.

BRP-Rotax
Operators Manual

Chapter: 2
ENGINE

TOPICS IN THIS CHAPTER

Operating fluids and battery	2
Coolant.....	2
Battery.....	2
Battery charging unit.....	4
Fuel.....	5

OPERATING FLUIDS AND BATTERY

See also table “important information (summary)” in Chapter 5.

COOLANT

Use only distilled water as engine coolant. If the kart is stored below the freezing temperature of water, make sure to drain the water from the cooling radiator and engine completely.

Step	Procedure
1	Open radiator cap and fill the system with coolant. Small radiator: approx. 0.52 liter / 0.137 gal for the complete cooling system Big radiator: approx. 0.7 liter / 0.185 gal for the complete cooling system
2	Close radiator cap.

ATTENTION

Observe the storage conditions.

Storage below the freezing temperature of water could lead to a damage of the cooling system and the engine.

ATTENTION

Exceeding the engine temperature could lead to serious engine failure.

The engine temperature should not exceed 85 °C / 185 °F.

BATTERY

See Fig. [Pos. 1: Charging connector](#).

The power for the ignition unit and electric starter is only supplied from the battery. With a fully charged battery of 12 V and 6.5 Ah, the engine can be started approximately one hundred times and operated over a period of approximately five hours. With the battery voltage decreasing to approximately 11 V the point will be reached when the battery voltage is too low to generate a spark for ignition.

ATTENTION

The lifespan of the battery will be drastically reduced by exhausting the battery completely.

Fully re-charge the battery before and after any operation of the kart.

NOTE

It is recommended to always carry a charged spare battery. The installed battery should be replaced with a fully charged battery before it is completely exhausted.

BRP-Rotax

Operators Manual

NOTE

If the spark plug is removed, to check if the battery still generates a spark, consider the following: with the spark plug removed it is easier for the electric starter to crank the engine, which reduces current absorption of the electric starter, resulting in battery voltage adequate to generate a spark. If the spark plug is fitted again, it may happen that the engine does not start.

NOTE

To charge a battery, the battery charging unit specified by ROTAX® and available as an accessory should be utilized (battery charger part no. 265148). When using the lithium battery available as spare part, the battery charger Optimate Lithium (part no. 581325) is mandatory.

NOTE

To be able to use the battery charger in your home country, please contact your nearest authorized ROTAX® distributor or one of their ROTAX® Service Centers to receive an adapter plug or adapter cable, respectively.

NOTE

This battery charger will switch over automatically to maintenance charge as soon as the target voltage is reached. Therefore overcharging with the result of ruining the battery will be impossible.

ATTENTION

Use of any other battery charger can impair the battery life or may ruin the battery.

BRP-Rotax Operators Manual

BATTERY CHARGING UNIT

When charging the battery take note of the following:

Step	Procedure
1	Connect battery charger to the charging connector (pos. 1).

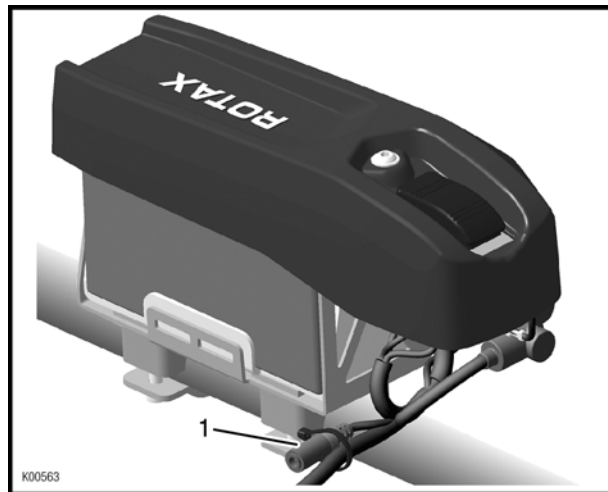

Figure 2.1: Pos. 1: Charging connector

Step	Procedure
2	Connect the battery charging unit on 110-230V, 50 - 60Hz power supply. During the charging procedure, the charge indicating lamp will light up red.
3	At completion of the charging process, the control lamp will change to green, but the charging current will remain, thus warranting a fully charged battery.
4	The charging time amounts to approx. 12 hours.

NOTE

The battery charger may be connected to the battery for a longer period, as the battery takes just the current required to be fully charged.

NOTE

A non-extinguishing red control lamp, even after 24 hours of charging, indicates that the charging capacity of the battery is diminishing.

NOTE

A red/green blinking of the charging control lamp indicates transition from main charging to additional charging and does not signal a faulty battery charger.

BRP-Rotax

Operators Manual

Step	Procedure
5	Unplug power supply to battery charging unit.
6	Remove output wires of the battery charger from the battery.
7	The battery is ready again for use.

ATTENTION

In addition to these directives, follow the advice of the battery charging unit manufacturer.

NOTE

When the battery is charged while not mounted on the kart, use the connector cable (part no. 266022). If needed, contact your authorized distributor or one of their ROTAX® Service Centers.

The charging condition of the battery can be estimated by using a commercially available measuring instrument.

FUEL

For engine operation, a mixture of unleaded gasoline of at least ROZ_{min.} 95 / 91 (RON +MON) / 2 and **fully synthetic** two-stroke oil, mixed at ratio 1: 50 (2% oil) has to be used.

ATTENTION

Carry out a correct running-in procedure.

See Chapter 4 section: Running-in procedure for the engine.

⚠ WARNING

Non-compliance can result in serious injuries or death!

When mixing fuel and fuelling do not smoke or allow open fire. Gasoline is highly flammable and explosive under certain conditions.

⚠ WARNING

Non-compliance can result in serious injuries or death!

Never perform mixing and fuelling in closed rooms, handle fuel in well ventilated areas only.

BRP-Rotax

Operators Manual

⚠ WARNING

Non-compliance can result in serious injuries or death!
Fuel the kart only when engine is not running and the combination switch is at OFF position.

⚠ WARNING

Risk of fire and explosion!
Make sure that fuel will not splash onto hot engine components or equipment.

⚠ WARNING

Non-compliance can result in serious injuries or death!
Pay attention to the safety advice of the kart manufacturer.

ATTENTION

Possible engine trouble!
Too much oil in the fuel mixture (more than 2%) could lead to engine trouble (e.g. coking of the exhaust valve, piston ring sticking).

ATTENTION

Possible engine blow-up!
Insufficient amount of oil in the fuel mixture (less than 2%) could result in e.g. piston seizure.

ATTENTION

Engine damage and damage to the intake system may occur.
Do not try any different sorts of fuel.

ATTENTION

Before each fuelling, shake fuel container well to ensure adequate mixing of the gasoline with the oil.

ATTENTION

Ensure that no contamination enters the fuel tank and the carburetor.

ATTENTION

Unleaded fuel has a limited storage life.
Store only the quantity of fuel in a container which will be needed in the near future.

BRP-Rotax

Operators Manual

ENVIRONMENTAL NOTE

Don't spill fuel. Absorb spilled fuel with appropriate drying agent and ensure ecological disposal.

BRP-Rotax
Operators Manual

NOTES

Chapter: 3
ENGINE CALIBRATION

TOPICS IN THIS CHAPTER

ENGINE CALIBRATION	2
Performance graphs	2
Carburetor calibration	3
Automatic-set-up	4
Manual set-up	7
Change of the carburetor main jet	11
Selection of the transmission ratio	14
Exchange of the clutch drum with chain sprocket fitted	16
Changing or renewal of the chain sprocket on the clutch drum	18

ENGINE CALIBRATION

PERFORMANCE GRAPHS

In this diagram, the different performance characteristics of the MAX engines are shown. The vertical Y-axis shows the power in kilowatts (kW). The horizontal X-axis shows the rotational speed in revolutions per minute (rpm).

For more information, please check the performance data sheets on www.rotax-kart.com.

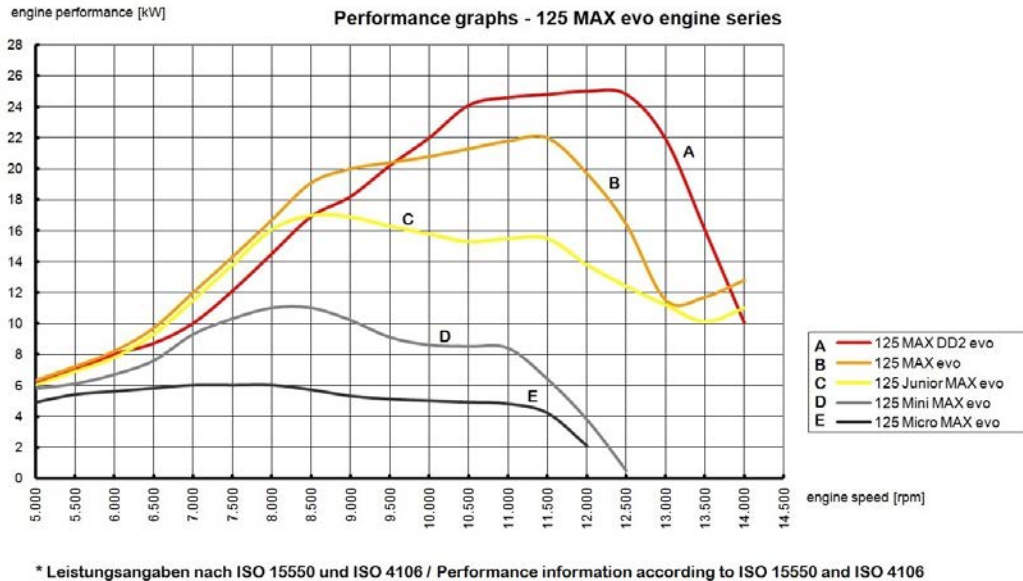

Figure 3.1: Performance graphs

CARBURETOR CALIBRATION

The standard carburetor calibration is for an ambient temperature of 25 °C / 77 °F and 400 m / 1310 ft above sea level. At operation with different temperatures and altitudes, the main jet of the carburetor has to be changed in accordance with Table 1, to optimize engine performance.

NOTE

For engine operation at an ambient temperature below 10 °C / 50 °F, make sure not to demand full power before the coolant temperature has reached 45 °C / 113 °F.

NOTE

The warranty by BRP-Rotax will no longer apply, if the carburetor calibration is carried out improperly and causes engine damage.

The following application for smartphones shows the individual setting of your ROTAX® 125 Max evo engine:

The ROTAX® Max Jetting Guide is an App for Android™ and iOS devices, designed to assist users with setting up the recommended main jet based on the ambient conditions and the type of engine. The perfect set-up can be calculated in two ways, either automatically - which requires a GPS signal and an internet connection, or manually - which requires certain knowledge about altitude and weather conditions.

BRP-Rotax Operators Manual

AUTOMATIC-SET-UP

Step	Procedure
1	Click on the white button located at the top of the screen saying "USE GPS POSITION FOR WEATHER DATA". After a short time the app will automatically provide all the necessary information regarding weather and geographical position.



Figure 3.2

Step	Procedure
2	As a second step, the engine type of the kart needs to be selected. Therefore, the button underneath the weather data needs to be clicked. The app will automatically show all potential Max evo engines, from which one can be selected by clicking on a certain engine type.

BRP-Rotax Operators Manual

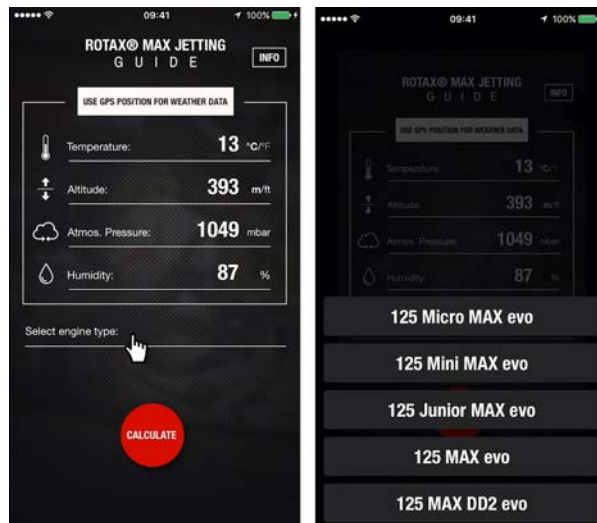

Figure 3.3

Step	Procedure
3	After all the necessary information has been provided and selected, you only need to click the circular red button saying “CALCULATE” at the bottom of the screen.

BRP-Rotax Operators Manual



Figure 3.4

Step	Procedure
4	Now the recommended main jet value will be provided. In case a second calculation needs to be made, you can start over by simply pressing the button saying "RESET" next to the calculated value.

BRP-Rotax Operators Manual



Figure 3.5

MANUAL SET-UP

Step	Procedure
1	In case no GPS signal or internet connection is available, the necessary data needs to be added manually, which of course requires knowledge about current weather conditions at the race track as well as the altitude. By clicking on the empty space next to “Temperature”, “Altitude”, “Atmos. Pressure” and “Humidity”, you are able to enter the required information. In terms of “Atmos. Pressure”, the atmospheric pressure at sea level has to be entered, usually the barometer shows the actual level.
2	As a second step, the engine type of the kart needs to be selected. Therefore, the button underneath the weather data needs to be clicked. The app will automatically show all potential Max evo engines, from which one can be selected by clicking on a certain engine type.
3	After all the necessary information has been provided and selected, you only need to click the circular red button saying “CALCULATE” at the bottom of the screen.
4	Now the recommended main jet value will be provided. In case a second calculation needs to be made, you can start over by simply pressing the button saying “RESET” next to the calculated value.

BRP-Rotax Operators Manual

Additional Information

- In case values are being entered manually, the provided numbers will turn from white to red if they are considered to be unrealistic.
- Depending on their preference, users can decide if they would like to use the metric or the imperial system. You can change between Celsius and Fahrenheit by simply clicking on the small °C or °F next to the value for temperature. The same works with feet and meter, where you can just click on the small m or ft located next to the value for altitude in order to change between the systems.

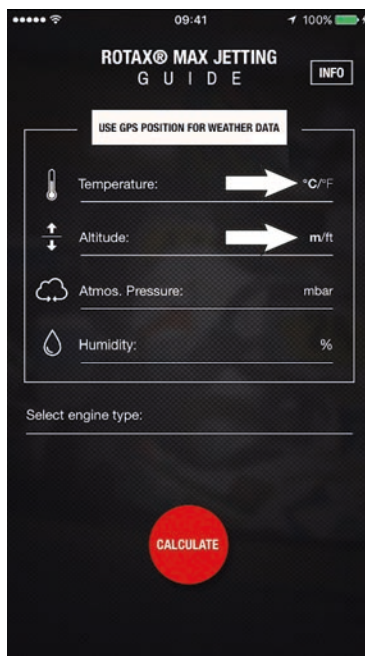

Figure 3.6

- In the top right corner, you can find a button called "INFO". By clicking this button, additional information about the app as well as setting up the carburetor like float height, position of the jet needle or the air adjustment screw can be found. By clicking the small red X underneath the info button, you can return to the home screen.

BRP-Rotax Operators Manual

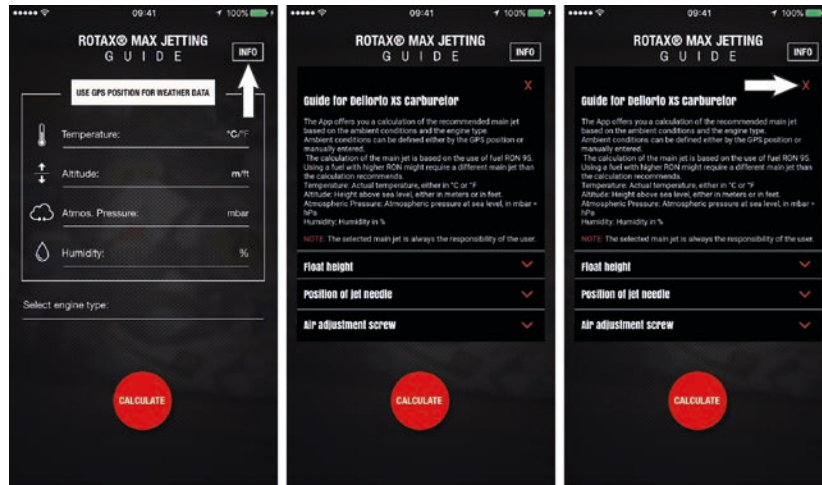

Figure 3.7

Please scan the following QR-code for a detailed instruction video:



Figure 3.8: QR- code

App Download

Please scan the following QR-code for your mobile device:



Figure 3.9: QR- code, Android device



Figure 3.10: QR- code, iOS device

For better understanding and as help for carburetor adjustment, the following figure describes the effect of the various adjustments, depending on the throttle position.

BRP-Rotax Operators Manual

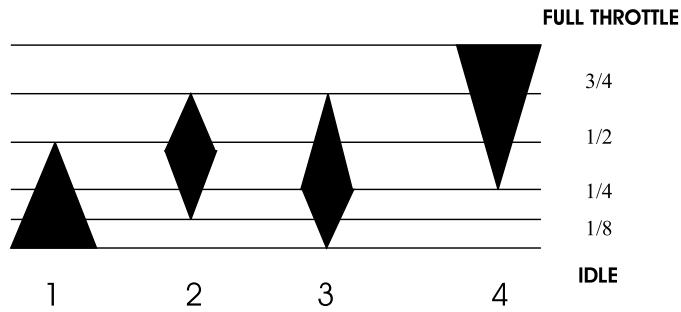

1 - AIR SCREW AND PILOT JET

2 - TYPE AND POSITION OF JET NEEDLE

3 - TYPE OF NEEDLE JET

4 - MAINJET

Figure 3.11: Various adjustments

BRP-Rotax Operators Manual

CHANGE OF THE CARBURETOR MAIN JET

To change the carburetor main jet, proceed as follows:

Tools required:

- Open-end wrench 19 mm
- Flathead screwdriver

NOTE

The carburetor must not be removed from the engine in order to change the jetting.

⚠ WARNING

Non-compliance can result in serious injuries or death!
Handle fuel in well-ventilated areas only.

⚠ WARNING

Non-compliance can result in serious injuries or death!
When handling with fuel, do not smoke or allow open flames. Gasoline and gasoline vapor are highly flammable and explosive under certain conditions.

⚠ WARNING

Risk of fire and explosion!
Make sure that fuel will not splash onto hot engine components or equipment.

ENVIRONMENTAL NOTE

Don't spill fuel. Absorb spilled fuel with appropriate drying agent and ensure ecological disposal.

Step	Procedure
1	Drain the fuel in the float chamber into a suitable clean tray by removing the plug screw (pos. 27) and gasket ring (pos. 26). NOTE <i>The fuel drained from the float chamber may be poured back into the fuel tank.</i>
2	Remove the main jet (pos. 15) and the main jet cup (pos. 14). NOTE <i>The size of the jet is imprinted on the face of the main jet.</i>

BRP-Rotax Operators Manual

Step	Procedure
3	Select the appropriate size of main jet, refer to ROTAX® Max Jetting Guide.
4	Install the main jet cup (pos. 14) in position and fit the corresponding main jet (see ROTAX® Max Jetting Guide).
5	Fit and hand-tighten the plug screw (pos. 27) and gasket ring (pos. 26).

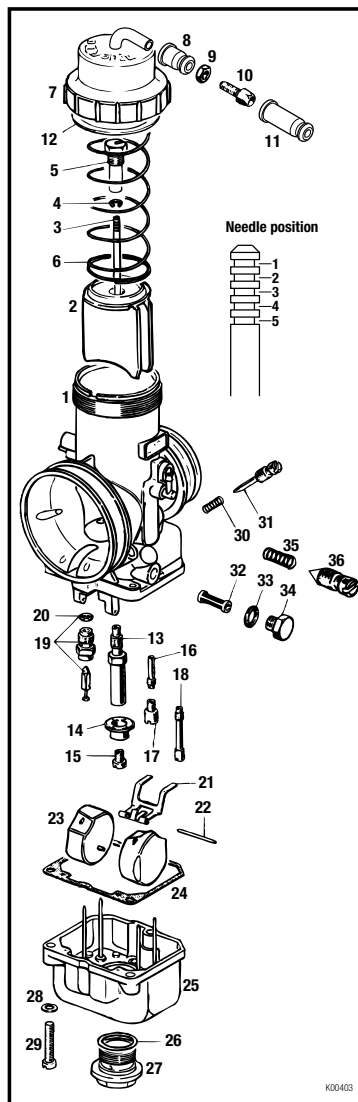

Figure 3.12: Components of carburetor

BRP-Rotax

Operators Manual

NOTE

In a disassembled carburetor, the position of the jet needle (pos. 3) can be changed. The standard position of the jet needle is 'position 2'. If the clip (pos. 4) is set in 'position 1' of the jet needle, the full mixture in part and full-load will become slightly leaner. If the clip (pos. 4) is set into 'position 5', the fuel mixture will become slightly richer in the part and full-load range.

NOTE

The fuel filter (pos. 32) is located below the fuel inlet on the carburetor, preventing contamination from entering the carburetor, which could impair operation of the carburetor.

Step	Procedure
6	Remove the hex. screw (pos. 34) and gasket ring (pos. 33).
7	Pull out the fuel filter (pos. 32) and clean the filter and fuel inlet.
8	Refit the fuel filter (pos. 32), the gasket ring (pos. 33) and hex. screw (pos. 34).

NOTE

When trying to start the engine it, will take a few seconds for the fuel pump to fill the float chamber and for the engine to start.

NOTE

With the adjustment screw (pos. 36), the idle speed of the engine can be adjusted. By turning in the adjustment screw (pos. 36) the idle speed increases and by turning out the screw (pos. 36) the idle speed will be reduced.

NOTE

With the adjustment screw (pos. 31), the fuel mixture formation can be adjusted. By turning in the adjustment screw (pos. 31), the air-fuel mixture will become richer at idling and by turning out the screw (pos. 31), the air-fuel mixture will become leaner at idling. The default setting of the adjustment screw are two full turns and one quarter of a turn (2 ¼) from inside to outside.

SELECTION OF THE TRANSMISSION RATIO

The transmission ratio (between chain pinion on the engine and chain sprocket on the rear axle of the kart) has an essential influence on the achievable lap time.

The routing (fluent or non-fluent) and the conditions (high or low tire grip) of the track require a certain transmission ratio to ensure an optimal lap time.

A longer transmission ratio (e.g. $12/72=6$) theoretically results at every rotational speed of the engine in a higher speed of the vehicle, but also in a higher driving resistance than with a shorter transmission ratio (e.g. $12/78=6.5$).

Calculation Example:

Rotational speed 13000 rpm.

Transmission ratio $12/72=6$

Circumference of rear tire 0.85 m

Vehicle speed = $13000 \times 60 : 6 \times 0.85 : 1000 = 110.5$ km/h

Rotational speed 13000 rpm.

Transmission ratio $12/82=6.5$

Circumference of rear tire 0.85 m

Vehicle speed = $13000 \times 60 : 6.5 \times 0.85 : 1000 = 102$ km/h

In principle, the transmission ratio should be chosen in a way that the engine is mainly operated in a speed range at which the engine performance is well above the driving resistance.

The following chart (125 MAX evo) shows that the difference between the engine performance and the driving resistance constantly increases at a speed range from 5000 to 9000 rpm, remains the same at a speed range from 9000 to 11500 rpm and decreases again at a speed about 11500 rpm onwards.

The smaller the difference between the engine performance and the driving resistance gets, the smaller is the excess of power and thus the acceleration potential of the engine. The intersection between the characteristic of driving resistance of the vehicle and the characteristic of engine performance indicates the peak rotational speed of the engine at the chosen transmission ratio.

With the „longer“ transmission ratio of $12/72=6$, the characteristic of driving resistance of the kart intersects the curve of engine performance at 13000 rpm – with this transmission ratio the engine will achieve a maximum rotational speed of 13000 rpm. This leads to a maximum speed of 110.5 km/h.

With the „shorter“ transmission ratio of $12/78=6.5$ the characteristic of driving resistance of the kart stays below the curve of engine performance over the whole speed range - with this transmission ratio the engine will achieve a maximum rotational speed of 14000 rpm. This leads to a maximum speed of 109.8 km/h.

ATTENTION

If a transmission ratio is chosen that results in a maximum rotational speed of 14000 rpm, it does not automatically mean that this leads to the best lap time. With a fluent routing, even a “longer” transmission ratio with a lower maximum rotational speed can lead to a better lap time.

BRP-Rotax Operators Manual

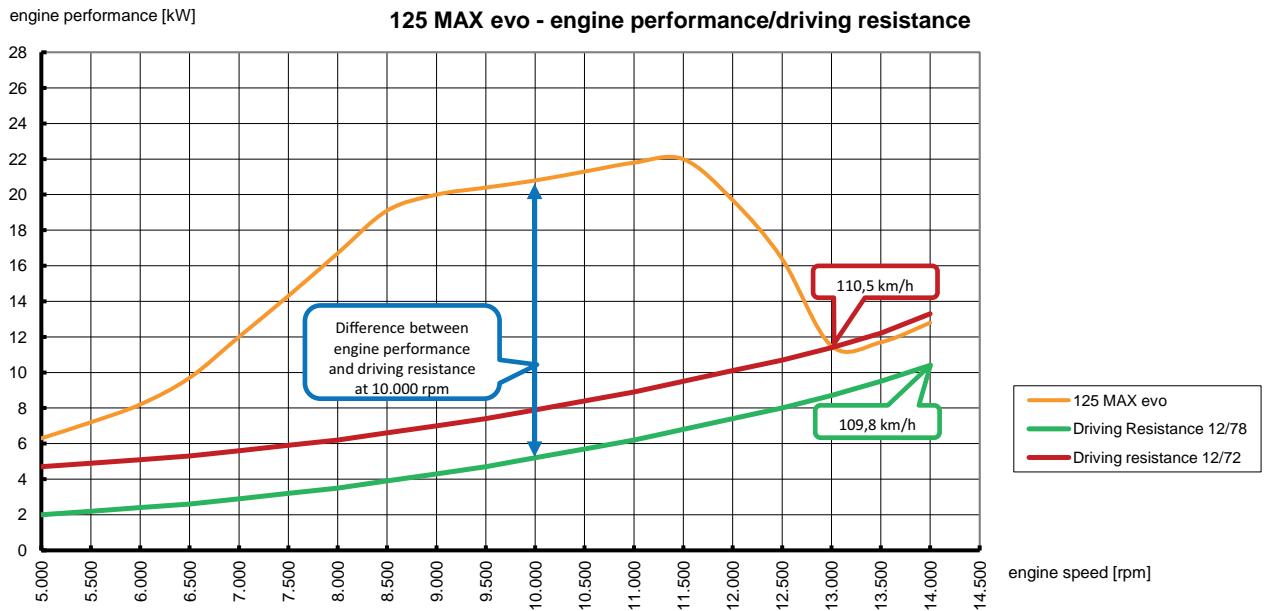

Figure 3.13

EXCHANGE OF THE CLUTCH DRUM WITH CHAIN SPROCKET FITTED

Step	Procedure
1	Remove spark plug connector for safety.
2	Use the fixation tool (pos. 15) to lock the starter gear.
3	Remove hex. nut (pos. 14) and thrust washer (pos. 13). See Fig. Components of clutch.
4	Remove clutch drum (pos. 7) with fitted chain sprocket.
5	Clear thread of crankshaft and hex. nut (pos. 14) from remains of bonding agent and degrease.

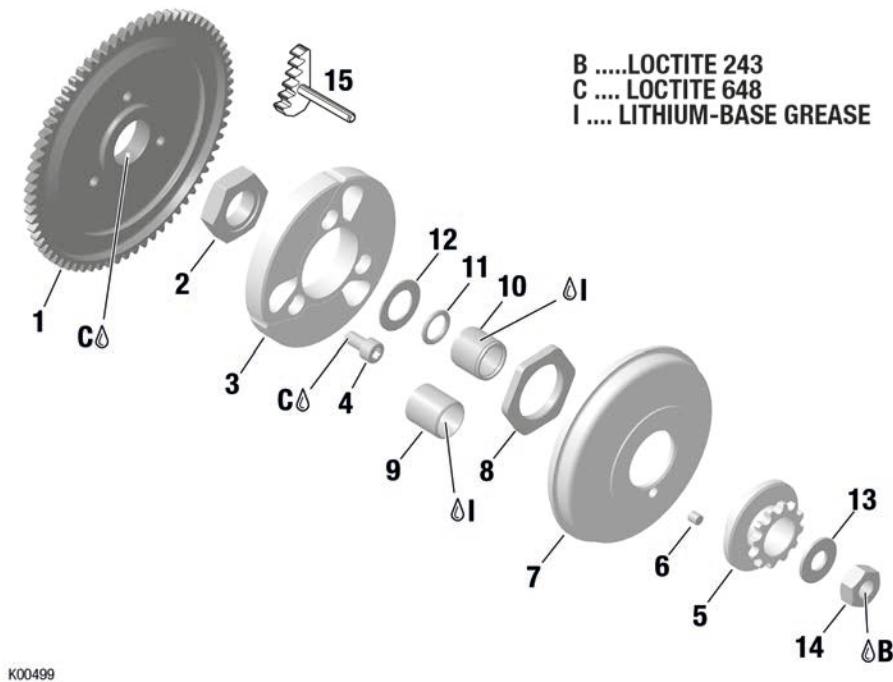

Figure 3.14: Components of clutch

1 Starter gear	2 Hex. nut M20x1.5	3 Clutch
4 Allen screw M6x12	5 Sprocket	6 Needle pin 5x5
7 Clutch drum	8 Hex. nut M28x1	9 Plain bearing 15x17x17.6
10 Needle cage K 15x19x7	11 O-ring 12x2.5	12 Thrust washer 15.2/25/1
13 Thrust washer 10/19/1.5	14 Hex. nut M10x1	15 Fixation tool assy.

BRP-Rotax Operators Manual

NOTE

Only sprockets with the ROTAX® logo are GENUINE ROTAX® parts!

NOTE

For the chain sprocket with 11 teeth, use the plain bearing (pos. 9) instead of the needle cage (pos. 10). The plain bearing has to be pressed flush into the bore of the chain sprocket with chamfered end leading.

If not absolutely necessary on a certain track, try not to use a chain sprocket with 11 teeth because of the heavy wear of the plain bearing (pos. 10) used only with this sprocket.

Step	Procedure
6	Apply grease on needle cage (pos. 9) when using a chain sprocket with 12, 13 and 14 teeth or on plain bearing (pos. 10) for chain sprocket with 11 teeth.
7	Fit the assembled clutch drum with the selected number of teeth.
8	Apply LOCTITE 243 on the thread of hex. nut (pos. 14).

NOTE

A smaller thrust washer (pos. 13) is required for the chain sprocket with 11 teeth, in comparison to the use of a chain sprocket with 12, 13 and 14 teeth.

Step	Procedure
9	Fit thrust washer (pos. 13) and hex. nut (pos. 14) and tighten nut to 35 Nm / 310 in.lb.
10	Remove fixation tool.

CHANGING OR RENEWAL OF THE CHAIN SPROCKET ON THE CLUTCH DRUM

The chain sprocket (pos. 2) is attached to the clutch drum (pos. 4) with a hex. nut (pos. 5) and torque is transmitted by a needle pin (pos. 3) (see Fig.). The proper changing or renewal of the chain sprocket is only feasible when using the appropriate fixture (pos. 1, part no. 277364). To change or renew the chain sprocket, proceed as follows:

NOTE

The fixture is furnished on one side with a centering pin for the chain sprocket with 11 teeth (17 mm diameter) and on the other side with a centering pin for the chain sprocket with 12, 13 and 14 teeth (19 mm diameter / 0.75 in).

NOTE

On the chain sprocket with 11 teeth, the plain bearing must be pressed out first (the plain bearing must be renewed after pressing out).

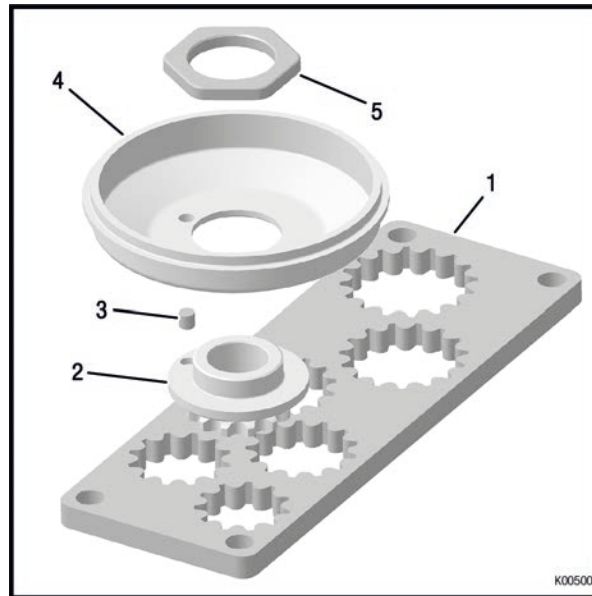

Figure 3.15: Fixation tool

- | | |
|------------------|---------------|
| 1 Fixation tool | 2 Sprocket |
| 3 Needle pin 5x5 | 4 Clutch drum |
| 5 Hex. nut | |

Step	Procedure
1	Clamp fixture (pos. 1) for the chain sprocket in a vice.
2	Place the clutch drum with chain sprocket on the respective centering pin so that the clutch drum is secured by the fixation pin.
3	Remove the hex. nut (pos. 5) from the chain sprocket.

BRP-Rotax Operators Manual

Step	Procedure
4	Clean all remains of the securing agent from the components.
5	Degrease the chain sprocket, the clutch hub and the hex. nut.
6	Place the new chain sprocket or the chain sprocket with required number of teeth on the respective centering pin of the fixture.
7	Place the needle pin (pos. 3) into the relevant bore of the chain sprocket.

NOTE

Fit the hex. nut (pos. 5) such that the machined face of the nut points towards the clutch drum.

Step	Procedure
8	Attach the chain sprocket with the hex. nut (pos. 5) to the clutch drum. Tightening torque 120 Nm / 89 lb ft.

BRP-Rotax
Operators Manual

NOTES

BRP-Rotax
Operators Manual

Chapter: 4
ENGINE OPERATION

TOPICS IN THIS CHAPTER

ENGINE OPERATING	2
Engine start	2
Stopping the engine.....	4
Running – in procedure for the engine.....	5
Setting of the exhaust valve timing (125 MAX evo only).....	6
Maintenance schedule for engine components	9
Operating Limits.....	11

ENGINE OPERATING

ENGINE START

Before starting the engine, make sure you have completed all necessary tasks for running the engine:

- ✓ Fuel tank full.
- ✓ Battery charged and connected.
- ✓ Battery voltage over 12 V.
- ✓ Carburetor Bowden cable is moving freely and carburetor piston connected in idle position.

At engine start proceed as follows:

Step	Procedure
1	On a cold engine, pull the choke lever (pos. 1,) into a vertical position.

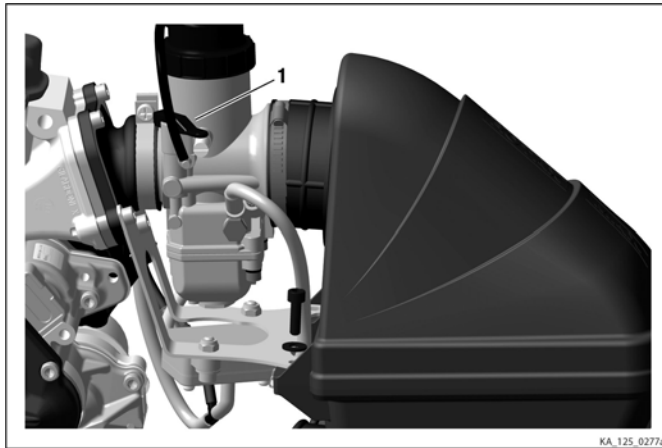

Figure 4.1: Choke lever

Step	Procedure
2	Press the power button once, the electric starter is activated (light turns on). Press the button again until the engine starts. See Fig. "Power button" NOTE <i>If the engine does not start, repeat the operation after a few seconds in the same manner.</i>

BRP-Rotax Operators Manual

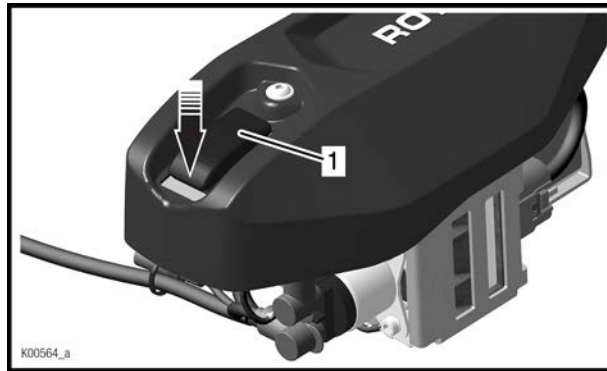

Figure 4.2: Power button

Step	Procedure
3	After engine start, take choke back slowly until engine idles smoothly without choke.

⚠ WARNING

Non-compliance can result in serious injuries or death!

Always wear protective clothing for kart operation (helmet, overall, gloves, shoes, neck and rib guards).

⚠ WARNING

Non-compliance can result in serious injuries or death!

Do not touch the engine, the radiator or the exhaust system during and immediately after kart operation. Risk of burning!

⚠ WARNING

Non-compliance can result in serious injuries or death!

During kart operation, beware of body or clothing contact with moving components of the kart.

⚠ WARNING

Non-compliance can result in serious injuries or death!

Comply with the safety advice of the engine and kart manufacturer.

⚠ WARNING

Non-compliance can result in serious injuries or death!

Inspect any part prone to wear (tyres, bearings etc.) before each kart event for good condition, in accordance with the directives of the kart manufacturer.

BRP-Rotax Operators Manual

ATTENTION

Non-compliance can result in engine damage!
Keep to running-in procedure as directed.

⚠ WARNING

Non-compliance can result in serious injuries or death!
Operate engine only within the specified limits.

⚠ WARNING

Non-compliance can result in serious injuries or death!
Only get in and out of the kart if engine is not running.

STOPPING THE ENGINE

See Fig. [Power button](#)

Step	Procedure
1	Press the power button and the engine will stop.

NOTE

If electric starter is activated, the ignition system will consume current. This can cause a deep discharge and damage to the battery.

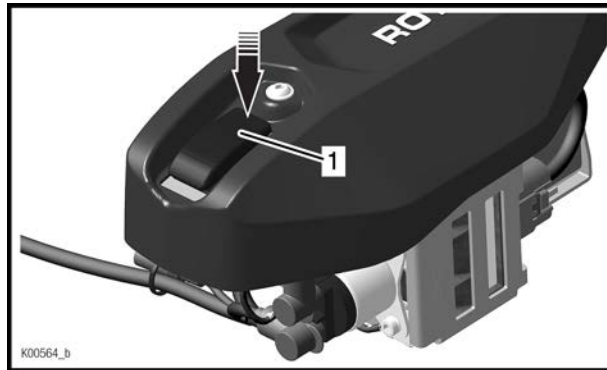

Figure 4.3: Power button

1 Power button

RUNNING – IN PROCEDURE FOR THE ENGINE

⚠ WARNING

Non-compliance can result in serious injuries or death!
Pay attention to the safety advice of the kart manufacturer.

To ensure that components have the longest possible lifespan, the engine must undergo a defined running-in period at first operation or after a repair of the crankshaft or displacement parts.

NOTE

Cover the radiator with the mounted windshield to reach the operating temperature earlier.

Make sure following requirements are fulfilled:



Use our JETTING APP and choose a 1 to 2 number bigger sized main jet than recommended.



For the first 10 liters of fuel use a mixing ratio of 1:33 (= 3% or 0.3 liter oil per 10 liters fuel).



Make sure that the coolant temperature reaches 45 °C (113 °F) before going full throttle.



Run the kart for 15 minutes at continuously changing load and engine speed fluctuation up to maximum rotational speed. Rotational speed for max. 2 seconds!



Afterwards reduce the main jet size step by step until standard size is reached.

After this running-in procedure, the full power of the engine may be used.

ATTENTION

Use only fully synthetic 2-stroke oil.
BRP-Rotax recommends the use of XPS Kart Tec oil.

SETTING OF THE EXHAUST VALVE TIMING (125 MAX EVO ONLY)

Tools required:
<ul style="list-style-type: none">• Allen key 4 mm or Socket wrench 8 mm

Due to the principle of equal parts, the harness for all MAX engines is identical. For engines without E-RAVE, the auxiliary cable (pos. 2, Fig.) must be attached and isolated to the ground cable so, that a possible contact with the engine ground does not affect the general function.

The opening time of the exhaust valve is set in the ECU and depends on the engine speed. However, the ECU allows two different modes of the exhaust valve opening. These can be selected by connecting an additional cable to the cylinder head cover.

ATTENTION
The ground wire must be continuously connected. This is important for the general function of the engine.

Variant 1: Additional cable on battery ground

A:

See [Ground wire](#)

The additional cable is **NOT** attached to the ground wire. The control of the exhaust valve timing is activated at 7900 rpm.

NOTE

Isolate the additional cable with an electrical/insulating tape to the ground wire so that a possible contact with the engine ground does not affect the function.

B:

See [Ground wire](#)

The additional cable is attached to the ground wire. The control of the exhaust valve timing is activated at 7600 rpm.

BRP-Rotax Operators Manual

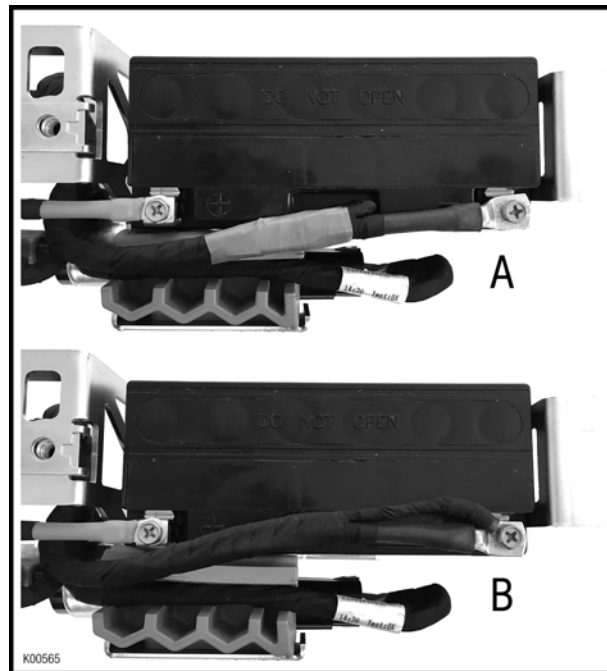

Figure 4.4: Ground wire

Variant 2: Additional cable on starter relay

A:

See [Cable on starter relay](#).

The additional cable is **NOT** attached to the ground wire. The control of the exhaust valve timing is activated at 7900 rpm.

NOTE

Isolate the additional cable with an electrical/insulating tape to the ground wire so that a possible contact with the engine ground does not affect the function.

B:

See [Cable on starter relay](#).

The additional cable is attached to the ground wire. The control of the exhaust valve timing is activated at 7600 rpm.

BRP-Rotax
Operators Manual

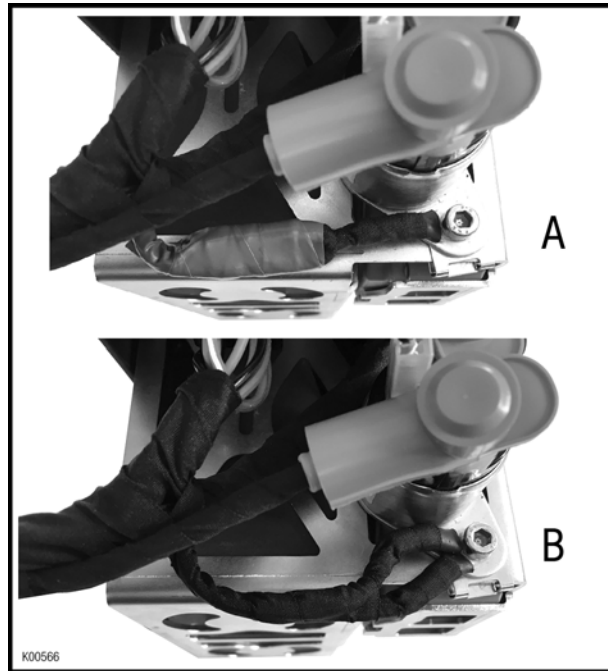

Figure 4.5: Cable on starter relay

NOTE

Either variant 1 or variant 2 has been installed in your engine.

BRP-Rotax
Operators Manual

MAINTENANCE SCHEDULE FOR ENGINE COMPONENTS

ATTENTION

Non-compliance with the specified maintenance schedule could result in engine damage.

ENGINE	FREQUENCY						NOTES
	Before every operation	After every operation	Every 2 hours of operation	Every 5 hours of operation	Every 10 hours of operation	Every 50 hours of operation	
Chain sprocket	X						Inspection for wear and deformation of teeth. Renew as required.
Exhaust system		X					Lubricate against corrosion.
Clean airfilter, apply oil, replace in case of visible damage.				X			After each rainy session, use air filter cleaner kit.
Fuel filter			X				Inspect for dirt.
						X¹⁾	Renew, ¹⁾ at least once a year.
Water pump	X						Inspect for oil or water on the leakage bore in the crankcase. In case of leakage, have a teardown inspection conducted by the authorized distributor.
Cooling circuit connections	X						Verify a tight fit and non leakage. Re-tighten or renew as required.
Oil level in the gear compartment			X				Check oil level, replenish as required.

BRP-Rotax
Operators Manual

ENGINE	FREQUENCY						NOTES
	Before every operation	After every operation	Every 2 hours of operation	Every 5 hours of operation	Every 10 hours of operation	Every 50 hours of operation	
Drive gears for balance shaft					X		Inspect for wear, renew as required.
Oil in the gear compartment						X¹⁾	Renew, ¹⁾ at least once a year.
Starter gear					X		Cleaning and greasing of bearing seals.
Needle bearing or plain bearing of the clutch drum			X				Cleaning and greasing, renew as required.
Friction lining of the fly weights					X		Inspect for wear, renew as required.
Damping material in the after muffler of the exhaust system					X		Renew.
Tear-down inspection of engine (must be conducted by an authorized ROTAX Service Center)						X	Inspect following components and replace if requested: Piston, piston pin and piston bearing cage, conrod and conrod bearing, main bearings of crankshaft, drive of balance shaft, sealing of water pump shaft.
RAVE			X				Clean hoses with compressed air.

BRP-Rotax

Operators Manual

OPERATING LIMITS

Operating the engine is only permitted under following conditions:
Recommended coolant temperature rang: 45 °C – 85 °C (113 °F – 185 °F).

ATTENTION

Operating the engine at a too low temperature could result in piston seizure.
The engine is only allowed to be run at peak performance after reaching the specified operating temperature.

NOTE

If the engine does not reach the minimum specified operating temperature due to the low ambient temperature, then the cooling efficiency of the radiator must be reduced by partially covering the radiator with adhesive tape.

⚠ WARNING

Non-compliance can result in serious injuries or death!
The maximum operating temperature of the engine must not be exceeded. If the temperature is too high, it may result in piston seizure.

NOTE

Dirt must be cleared from the lamination of the radiator at regular intervals to achieve the best cooling performance.

BRP-Rotax
Operators Manual

NOTES

Chapter: 5
PRESERVATION AND TRANSPORT

TOPICS IN THIS CHAPTER

Preservation and transport	2
Preservation of engine and equipment	2
Transport of the kart.....	2
IMPORTANT INFORMATION (SUMMARY).....	3
Notes	4

PRESERVATION AND TRANSPORT

PRESERVATION OF ENGINE AND EQUIPMENT

For longer periods out of operation (winter time), make sure that the engine will be properly preserved.

Step	Procedure
1	Detach carburetor, drain fuel from carburetor and close carburetor openings to ensure that no dust or dirt can enter.
2	If the vehicle gets stored at temperatures below freezing, drain the entire cooling system and clean the cooling circuit with pressure air.

⚠ WARNING

Not following this may lead to engine damage.

Step	Procedure
3	Close intake and exhaust port of engine with adhesive tape so that they are airtight.
4	Apply oil on exhaust system to prevent corrosion.
5	Remove battery from the fixture and charge periodically with the specified battery charger.

TRANSPORT OF THE KART

If the carburetor is still filled with fuel, the kart is only allowed to be transported in a horizontal position.

If the kart is to be transported in a vertical position, the fuel must be drained from the carburetor first.

NOTE

If the kart is in a vertical position at transport, the remaining fuel in the carburetor might flow into the crankcase with the result that the engine won't start at next try.

Step	Procedure
1	Remove drain screw on float chamber of carburetor and collect the fuel in a suitable container.
2	Clean drain screw and refit.

BRP-Rotax
Operators Manual

IMPORTANT INFORMATION (SUMMARY)

IMPORTANT INFORMATION	Liter	GAL.	SPECIFICATION	RECOMMENDED BRANDS
FUEL			Unleaded fuel of minimum octane level of 95 ROZ resp. 91 MOZ	
2-STROKE OIL			Fully synthetic	XPS Kart-Tec
OIL IN FUEL MIX- ING RATIO			During break-in: 1:33 (=3% oil) During normal use: 1:50 (=2% oil)	
COOLING SYSTEM	0.80	0.21	Pure water (if kart is stored at temperatures below 0 °C/ 32 °F: drain the system)	
BALANCE DRIVE GEARBOX OIL	0.10 (100 cc)		Engine oil SAE 15W-40	XPS Kart-Tec
SPARK PLUG			see IPC	NGK

BRP-Rotax
Operators Manual

Index

A

Automatic-set-up.....4

B

Balance shaft.....2

Battery and battery charging unit.....2

Battery charging unit4

C

Carburetor3

Carburetor calibration3

Centrifugal clutch4

Change of the carburetor main jet..... 11

Changing or renewal of the chain sprocket on
the clutch drum.....18

Coolant2

Cooling circuit.....2

D

Design of the ROTAX engine, Type 125 MAX2

E

Electric starter.....2

Electro pneumatically exhaust timing control3

Engine calibration2

Engine operating.....2

Engine operation.....1

Engine start2

Exchange of the clutch drum with chain
sprocket fitted..... 16

Exhaust system3

F

Fuel5

Fuel pump3

G

General2

I

Ignition unit.....2

IMPORTANT INFORMATION (SUMMARY).....3

Intake silencer3

INTRO1

M

Maintenance schedule for engine components9

Manual set-up.....7

N

NOTES4

O

Operating fluids and battery2

Operating limits..... 11

P

Performance graphs.....2

Preservation and transport.....2

Preservation of engine and equipment.....2

R

Running – in procedure for the engine5

S

Selection of the transmission ratio14

Setting of the exhaust valve timing.....6

Stopping the engine4

T

Technical Description1

Transport of the kart2

ROTAX[®]
KARTING

