

ROTAX[®]
KARTING

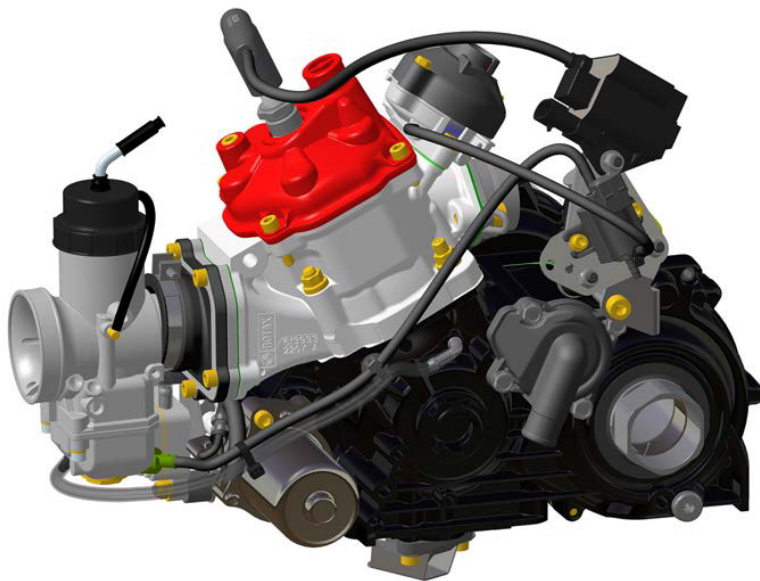

REPAIR MANUAL



for ROTAX[®]-engines type

125 MAX DD2 evo

Part no. 298063

BRP-Rotax
REPAIR MANUAL

Chapter: INTRO
GENERAL INFORMATION

- Preface** Before carrying out repair work on the engine, read the Repair Manual carefully. If any passages of the Manual are not clearly understood or if you have questions, please contact an authorized Distribution or Service Center for ROTAX®-kart engines.
- Contents** This Repair Manual contains instructions for all the necessary repair and maintenance work on the ROTAX®-Engine Type 125 MAX DD2 evo.
- Symbols used** This Manual uses the following symbols to emphasize particular information. This information is important and must be observed.

⚠ WARNING

Identifies an instruction, which if not followed may cause injury or endanger the life of the driver, mechanic or third party.

ATTENTION

Denotes an instruction which if not followed may severely damage the engine. Noncompliance might lead to health hazards under certain conditions.

ENVIRONMENTAL NOTE

Environmental notes give you tips on environmental protection.

NOTE

Indicates supplementary information which may be needed to fully complete or understand an instruction.

✓ Denotes a checking operation

TIP This information gives you additional advice and tips

BRP-Rotax
REPAIR MANUAL

NOTES

BRP-Rotax
REPAIR MANUAL

Chapter: Chapter 1
GENERAL NOTE

TOPICS IN THIS CHAPTER

Abbreviations and terms used in this Manual	3
Safety	4
Safety notice	4
Instruction	5
Technical documentation.....	6
Use for intended purpose	6
Technical data	7

BRP-Rotax REPAIR MANUAL

- Purpose** This Repair Manual is based on information and the state-of-knowledge of BRP-Rotax of the product current at the date of issue.
- Documentation** For additional information on engines, maintenance or parts, you can also contact your nearest authorized ROTAX®-Engine distributor.
- ROTAX® distributors** ROTAX® Authorized Distributors for Kart Engines. See on web at the official Homepage <http://www.rotax-kart.com>.
- Engine serial number** If you have any concerns or questions, always keep your engine serial number ready for questions from your dealer, as the manufacturer makes modifications to the engine for product improvement. The engine number is stamped on the clutch side housing half. See Figure 1.

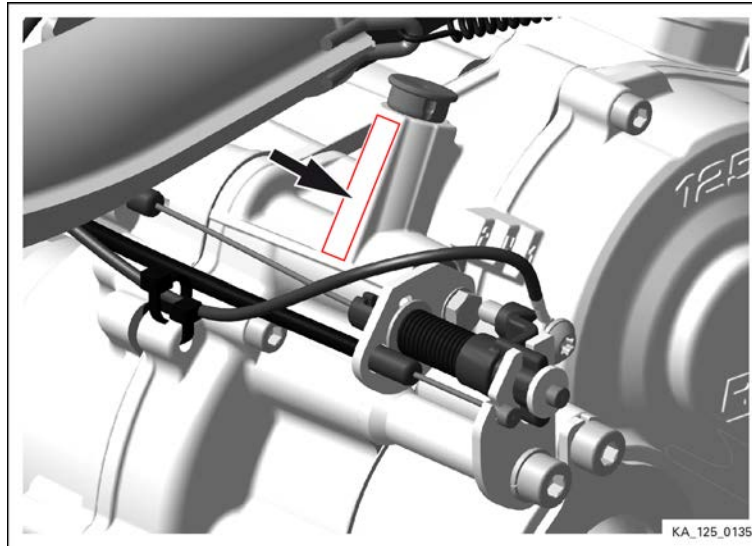

Figure 1.1: Position of the engine serial number

BRP-Rotax
REPAIR MANUAL

ABBREVIATIONS AND TERMS USED IN THIS MANUAL

Abbreviations

Abbreviations	Description
°C	Degree Celsius (Centigrade)
°F	Degree Fahrenheit
rpm	Revolutions per minute
e.g.	for example
125 MAX DD2 evo	see Manual (Type designation)
INTRO	Introduction
IPC	Illustrated Parts Catalog
i.r.	if required
h	hours
OM	Operators Manual
kg	kilograms
MON	Motor Octane Number
n.a.	not available
Nm	Newton meter
Rev.	Revision
RON	Research Octane Number
RM	Repair Manual
S/N	Serial Number
SI	Service Instruction
SL	Service Letter
part no.	Part number
V	Volt

BRP-Rotax REPAIR MANUAL

SAFETY

- General note** Although the reading of such information does not eliminate the hazard, the understanding the information will promote its correct use. Always take care by conducting manual work and use safety equipment. The information and components-/system descriptions contained in this Manual are correct at the time of publication. BRP-Rotax, however, maintains a policy of continuous improvement of its products without imposing upon itself any obligation to install them on its products previously manufactured.
- Revision** BRP-Rotax reserves the right at any time, and without incurring obligation, to remove, replace or discontinue any design, specification, feature or other details.
- Specifications** Specifications are given in the SI metric system with the USA equivalent in parenthesis.

SAFETY NOTICE

General note

⚠ WARNING

Non-compliance can result in serious injuries or death!
Comply with the safety advice of the engine and kart manufacturer.

This information relates to the preparation and use of ROTAX® Kart engines and has been utilized safely and effectively by BRP-Rotax. However, BRP-Rotax disclaims liability for all damage and/or injuries resulting from the improper use of the contents. BRP-Rotax strongly recommend that any service be carried out and/or verified by a highly skilled professional mechanic.

- Manual** This Manual has been prepared as a guide to correctly service and maintain all ROTAX® Kart engines.
This Manual uses technical terms which may be slightly different from the ones used in the Illustrated Parts Catalog.
It is understood that this Manual may be translated into another language. In the event of any discrepancy the English version prevails.
- Warning** It is your responsibility to be completely familiar with the safety instructions including warnings and cautions described in this Manual. These warnings and cautions advise of specific operating and servicing methods that, if not observed, can cause a serious engine malfunction or cause the engine to lose power which can result in serious injury, damage to equipment or even to death.
It is, however, important to understand that these warnings and cautions are carefully checked. BRP-Rotax can not evaluate and advise the user of all conceivable ways in which service might be done or of the possible hazardous consequences that may occur.
- Safety instruction** In addition to observing the instructions in our Manual, general safety and accident preventative measures, legal regulations and regulations of any superior authority must be observed.
Where differences exist between this Manual and regulations provided by any authority, the more stringent regulation should be applied.

BRP-Rotax REPAIR MANUAL

Illustration The content depicts parts and/or procedures applicable to the particular product at its time of manufacture. It does not include dealer modifications, whether authorized or not by BRP-Rotax, after manufacturing the product.

Locking devices Locking devices (e.g. locking tab, self-locking fasteners, etc.) must be installed or replaced with new ones, where specified. If the efficiency of a locking device is impaired, it must be replaced.

Torque wrench tightening Torque wrench tightening specifications must be strictly adhered to.

NOTE

If not specified otherwise, the threads are not lubricated when fastened.

INSTRUCTION

General note Engines require instructions regarding their application, use, operation, maintenance and repair. Technical documentation and directions are useful and necessary complementary elements for personal instructions, but can by no means substitute theoretical and practical instructions. These instructions should cover explanation of the technical context, advice for operation, maintenance, use and operational safety of the engine.

Safety notice In this technical Manual passages concerning safety are especially marked. Pass on safety warnings to other users!

Modifications Non-approved modifications to the engine and associated components likewise releases BRP-Rotax from its warranty obligations.

Accessories This engine must only be operated with accessories supplied, recommended and released by BRP-Rotax. Modifications are only allowed after the exceptional advice or approval by the engine manufacturer.

Spare parts

ATTENTION

Spare parts must comply with the requirements defined by the engine manufacturer. This is only warranted by use of GENUINE ROTAX® spare parts and/or accessories (see IPC) or suitable equivalent in the manufacturer's opinion. Otherwise, any limited warranty by BRP-Rotax is null and void (see latest Warranty Conditions). Spare parts are available at the authorized ROTAX® Distribution- and Service Center. Any warranty by BRP-Rotax becomes null and void if spare parts and or accessories other than GENUINE ROTAX® spare parts and/or accessories are used (see latest Warranty Conditions).

Tools

ATTENTION

Use only tools and appliances which are either cited in this Manual or in the Illustrated Parts Catalog of the relevant engine type for exceptional repair work.

BRP-Rotax REPAIR MANUAL

Engine A fundamental requirement is that on removal of the engine for repair or maintenance purposes it should be secured on the Special Tools part no. 877930 (Trestle support) and part no. 676052 (Trestle adapter) available at your authorized Distributor or Service center for ROTAX® Kart Engines.

TECHNICAL DOCUMENTATION

General note The information contained is based on data and experience that are considered applicable for skilled mechanics under normal conditions.
Due to the fast technical progress and fulfillment of particular specifications of the customers it may occur that existing laws, safety prescriptions, constructional and operational regulations cannot be transferred completely to the object bought, in particular for special constructions, or may not be sufficient.

Status The current edition of the Manual is shown at the bottom of the pages or on the front cover.

Reference Any reference to a document refers to the latest edition issued by BRP-Rotax, if not stated otherwise.

Illustrations The illustrations in this Manual are sketches and show a typical arrangement. They may not represent in full detail or the exact shape of the parts which have the same or similar function. Therefore deduction of dimensions or other details from illustrations is not permitted as the scale may not be 1:1.

NOTE

The Illustrations and Documents in this Manual are stored in a database and are provided with a consecutive number.

This number (e.g. KA_125MAX_001) is of no significance for the content.

USE FOR INTENDED PURPOSE

Safety note

⚠ WARNING

Non-compliance can result in serious injuries or death!

Use The ROTAX Engine Type 125 MAX DD2 has been designed and developed exclusively for use in a Kart. Any other use renders the BRP-Rotax factory limited warranty null and void.

Maintenance and repair conditions Use for intended purpose also includes observation of the operational, maintenance and repair conditions prescribed by the manufacturer. This is a crucial factor concerning the reliability of the engine and can increase the durability of the engine.

BRP-Rotax
REPAIR MANUAL

TECHNICAL DATA

Engine Type	125 MAX DD2 evo
Bore/stroke	54.00 mm / 54.5 mm
Displacement	125.0 ccm
Nominal power (max.)	25 kW at 12.000 rpm
Torque (max.)	22 Nm at 10.500 rpm
Idle speed	1500 rpm
Highest permissible speed	14000 rpm (at operation on the track, under load)
Ignition unit	Contactless, DellOrto digital coil ignition
Spark plug	NGK GR9DI-8 part no. 298103
Electrode gap	<1 mm
Fuel	SUPER, unleaded fuel
RON (min.)	Min. 95 Octane
Cooling	Liquid cooling: Cooling circuit with integrated coolant pump
Flow rate of the coolant pump	approx. 22 liters at 11000 rpm
Coolant mixture	100 % Water (distilled). Drain water after operation in cold condition to prevent freezing.
Coolant capacity	0.9 liter
Engine lubrication	Oil-in-gasoline lubrication, synthetic 2 Stroke oil (ROTAX XPS KART-TEC Oil part no. 29460 or ROTAX SYNMAX Oil recommended).
Mixture ratio	1:50 (2 % oil)
Lubrication of the differential drive	SAE Engine oil 15W-40
Engine oil capacity	130 ml
Clutch engagement speed	approx. 4000 rpm
Power transmission from centrifugal clutch to the rear axle of the kart	unsynchronized two speed gearbox
Weight /dry	approx 16.8 kg without intake silencer, carburetor, fuel pump, radiator, exhaust and battery. approx 28.8 kg with complete powerpack

BRP-Rotax
REPAIR MANUAL

NOTES

BRP-Rotax
REPAIR MANUAL

Chapter: Chapter 2
MAINTENANCE

TOPICS IN THIS CHAPTER

General note	2
Authorized personnel	3
Process advice	4
Consumable materials	6
Special tools	8
Inspection and servicing intervals of the engine components	10

Contents The information given in the Repair Manual is based on data and experience which are considered to be applicable for a skilled mechanic under normal working conditions.

Table of contents In this chapter the repair of engine ROTAX® 125 MAX DD2 evo is described. Some overlapping maintenance instructions are treated as generally valid information at the beginning of this section.

BRP-Rotax
REPAIR MANUAL

GENERAL NOTE

Safety notice

⚠ WARNING

Non-compliance can result in serious injuries or death!

Besides our instructions in the documentation supplied, also respect the generally valid safety and accident preventive directives and legal regulations.

Procedures and limits	The procedures and limits in this Manual constitute the manufacturers official recommendation for engine maintenance and operation
Instruction	The guidelines given in the Repair Manual are useful and necessary supplements to training. They, however, cannot substitute competent theoretical and practical personal instruction.
Modifications	Non-authorized modifications as well as the use of components and auxiliary components not corresponding to the installation instructions exclude any liability of the engine manufacturer
Parts and accessories	We particularly emphasize that parts and accessories not supplied as genuine BRP-Rotax parts are not verified for suitability by BRP-Rotax and thus are not authorized for use. Installation and/or use of such products may possibly change or negatively influence the constructive characteristics of the engine. For damages resulting from use of non-genuine parts and accessories manufacturer refuses any liability
Special tools	Maintenance of engines and systems requires special knowledge and special tools. Use only the special tools recommended by BRP-Rotax when disassembling and assembling the engine.

BRP-Rotax
REPAIR MANUAL

AUTHORIZED PERSONNEL

General note

It is a requirement that all organizations or individuals have the required special tooling available and the necessary, training or experience to perform all tasks outlined.

Type-specific training

Any task outlined herein may be performed if the organization or individual has met the following conditions:

Requisite knowledge
<ul style="list-style-type: none">• Experience in performing the task and knowledge of ROTAX® Installation/Operators Manual and Repair Manual
Including:
<ul style="list-style-type: none">• Suitable work environment to prevent contamination or damage to engine parts or modules.• Appropriate tools and fixtures as outlined in the ROTAX® Repair Manual.• Reasonable maintenance practices are utilized.

Information

Maintenance organizations and individuals are encouraged to contact BRP-Rotax through its worldwide distribution network for information and guidance on any of the tasks outlined herein.

BRP-Rotax
REPAIR MANUAL

PROCESS ADVICE

Safety note

⚠ WARNING

Non-compliance can result in serious injuries or death!
When carrying out maintenance and service work, respect without fail the safety regulations.

Ignition “OFF”

⚠ WARNING

Non-compliance can result in serious injuries or death!
This precautionary measure serves to avoid any injuries in case of an unintentional start of the engine. Principally ensure the following at each maintenance event: 1.) Ignition “OFF” and system grounded, 2) Disconnect battery and secure engine against unintentional operation.

Handling of fluids

⚠ WARNING

Non-compliance can result in serious injuries or death!
Non-compliance with this instruction may cause severe burns or scalding! Hot engine parts! Always allow the engine to cool down to ambient temperature before starting work.

At maintenance of cooling-, lubricating and fuel system take care without that no contamination, metal chips, foreign material and/or dirt enters the system.

Disassembly

At disassembly of the engine, mark the components as necessary to avoid any mix-up. Take care of these marks, do not ruin them.

Tool

ATTENTION

In order to avoid mechanical damages, never loosen or tighten screws and nuts with pliers but only with the specified tools.

Safety wiring

ATTENTION

If during disassembling/reassembling the removal of a safety item (e.g. safety wiring, self-locking fastener, etc.) should be necessary, it must be always replaced by a new one.

BRP-Rotax REPAIR MANUAL

Cleaning of parts

ATTENTION

All metal and synthetic parts are generally washed with suitable cleaning agents. Before using new and unknown cleaning agents check the compatibility of materials.

Removed parts

Before re-using disassembled parts, clean, check and refit them as per instructions. Use clean screws and nuts only and inspect face of nuts and thread for damage. Check the contact faces and threads for damages. In case of doubt, use new screws and nuts

Measurements

When making low tolerance measurements ($s < 0.1$ mm) and in measuring bearing and housing components, the temperature of the components and their surroundings must be in the range 20 °C - 25 °C (68 °F – 77 °F). Only used certified measuring tools!

Nuts

Once loosened, **always** replace self-securing nuts!

Sealing rings, O-rings

At reassembly of the engine, replace all sealing rings, gaskets, securing elements, O-rings and oil seals.

Re-assembly

Before re-assembly check components whether parts are missing. Only use adhesives, lubricants, cleaning agents and solvents indicated in the maintenance instructions. If not respected, damage may be the consequence and no warranty claim.

BRP-Rotax
REPAIR MANUAL

CONSUMABLE MATERIALS

General note

ATTENTION
Use only the specified or technically equivalent materials from BRP-Rotax for all maintenance work. When handling chemicals, comply with all the customary regulations and specifications of the producer, including the expiry date and instruction.

NOTE

If necessary contact the manufacturer concerning the comparability of the consumable materials. In some cases information can be obtained from the local authorized distributors and service partners for ROTAX engines.

NOTE

Respect the manufacturers instruction concerning the curing time and the expire date of the particular surface sealing compound.

The materials specified have been tested for a long time and are suitable for all operating conditions indicated by the manufacturer.

No.	Part no.	Description, Application	Qty.
1	897651	LOCTITE 243 blue , medium-duty screw securing agent	10 ml (0.003 US gal.)
2	899788	LOCTITE 648 geen , high strength screw securing agent	5 ml (0.001 US gal.)
3	297434	LOCTITE Anti-Seize 15378 , for the prevention of fretting corrosion	50 g (0.11 lb)
4	897161	MOLYKOTE 111 long-term lubricant for shaft seal	100 g (0.22 lb)
5	897330	Lithium-based grease or Dow Corning to prevent leakage current	250 g (0.55 lb)
6	25473	XPS Kart TEC DD2 Kart Gear oil Lubricant	1000 ml (0.26 US gal)
7	898364	Klueber Isoflex Topas Nb52 Lubricating grease	400 g (0.88 lb)
8	296160	Engine gasket set	1
-	n.a.	Cleaning agents	as required

BRP-Rotax REPAIR MANUAL

ATTENTION

Use only approved cleaning agents (e.g. kerosine, varsol, etc.) for cleaning all metal parts.

Do not use lye-based cold cleaner or degreasing agents. Do not clean coolant or oil hoses with aggressive solutions. Clean off sealing compound residue with sealant remover. Soak combustion chamber, piston and cylinder head with cleaning agent and remove combustion residues with a bronze brush. Very good results have been achieved with "Clenvex 2000". It is a solvent-cold cleaner, free of halogen, on the basis of selected fuel fractions with tensides and is biologically disposable. Never use caustic or corrosive cleaning.

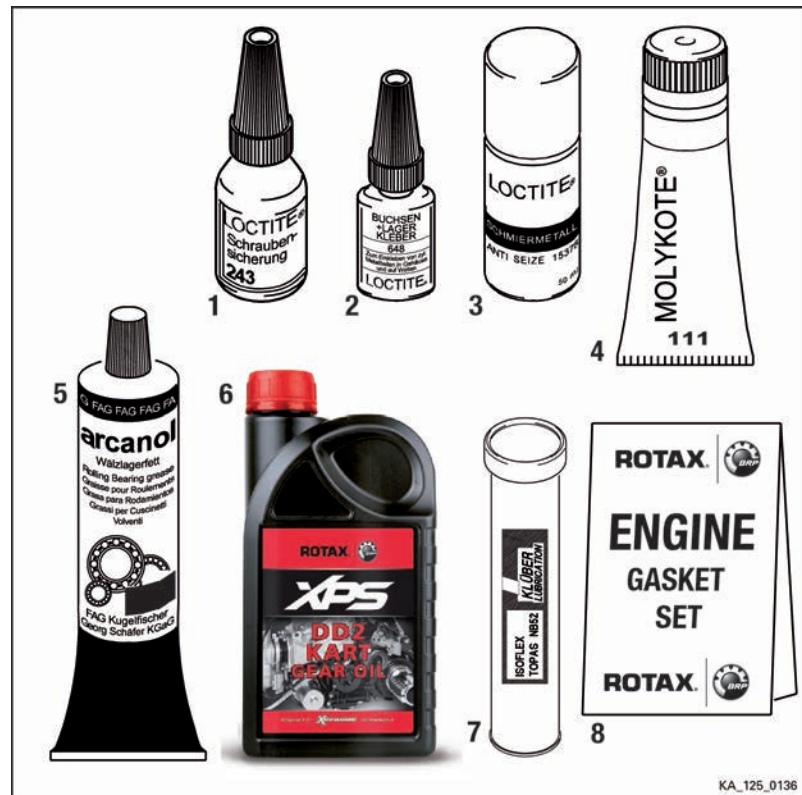

Figure 2.1

BRP-Rotax
REPAIR MANUAL

SPECIAL TOOLS

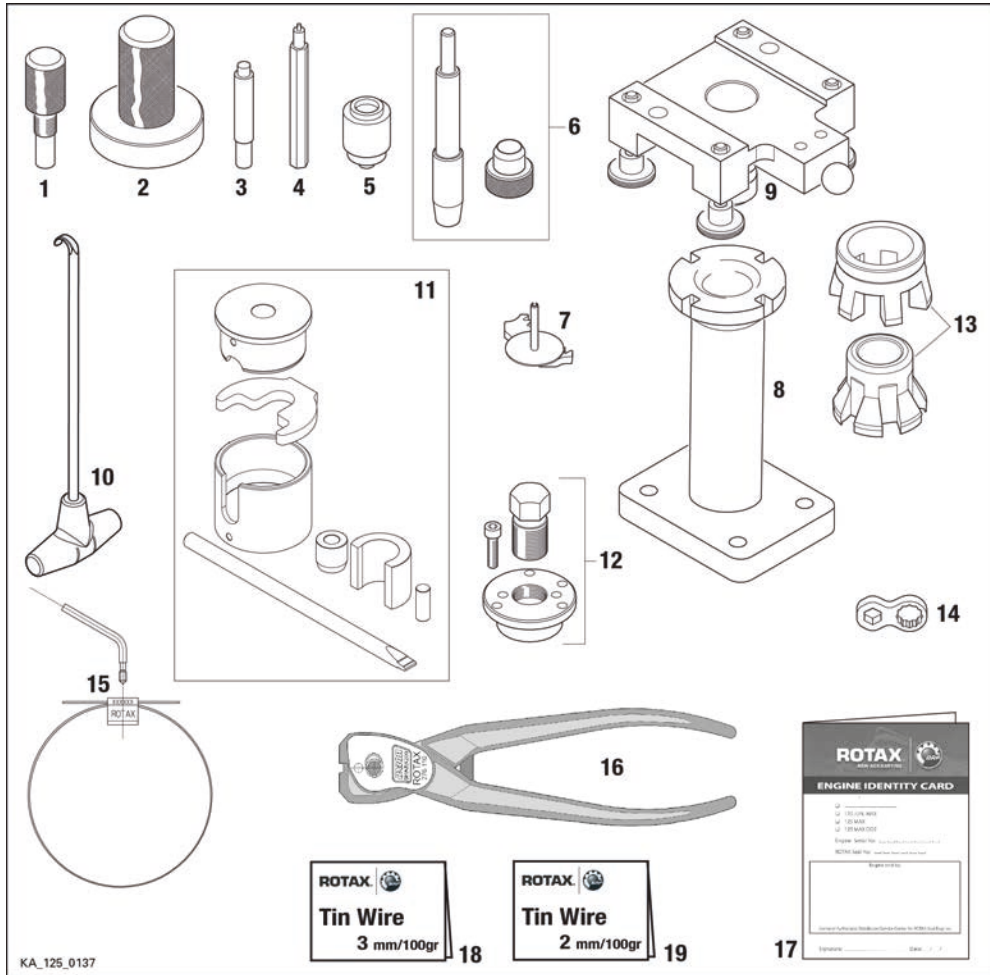

Figure 2.2

BRP-Rotax
REPAIR MANUAL

No.	Part no.	Description
1	277381	Fixation tool for crankshaft
2	676022	Insertion jig
3	676030	Insertion jig
4	676032	Insertion jig
5	676021	Insertion jig
6	676035	Insertion tool
7	676202	Fixation tool assy. DD2
8	877930	Trestle support
9	676052	Fixing plate for engine
10	251680	Spring hook (For exhaust springs)
11	276051	Crankshaft repair jig
12	276016	Puller assy.
13	276070	Assembly tool bellow spring exhaust v.
14	676110	Wrench adapter 11/8 cylinder
15	297041	ROTAX-SEAL with bar code. With registered serial no. For authorised distributors only.
16	276110	ROTAX SEAL CALLIPER For authorised distributors only.
17	297240	Engine identity card. For authorised distributors only.
18	580132	Tin wire 3 mm –100 GR
19	580130	Tin wire 2 mm –100 GR

INSPECTION AND SERVICING INTERVALS OF THE ENGINE COMPONENTS

Safety note

⚠ WARNING		
<p>Non-compliance can result in serious injuries or death! All repair and maintenance work must only be carried out by a qualified technician.</p>		

Points of inspection	Interval Operating hours	Chapter Reference
Inspection, remedial action	as indicated	
1) General		
Inspect spark plug, replace if necessary	Inspect before every operation of vehicle	
Replace spark plug.	Every 25 hours of operation	
2) Cooling system		
Check coolant level.	Inspect before every operation of vehicle	
Inspect water pump for sealing, in the event of egress of oil or coolant from the overflow orifice, have the pump repaired by an authorised service center.	Inspect before every operation of vehicle	
Inspect the cooling water connections on the cooler housing and cylinder head cover for tightness and sealing.	Inspect before every operation of vehicle	
Inspect the radiator hoses and hose clamps on the engine and radiator for tightness and sealing.	Inspect before every operation of vehicle	
3) Carburetor and intake silencer		
Inspect the carburetor connections to the engine and to the intake silencer for tightness.	Immediately after every collision	
Clean the filter element in the intake silencer and lubricate with air filter oil, replace damaged filter element.	Every 10 hours (depending on the conditions of use)	

BRP-Rotax
REPAIR MANUAL

Points of inspection	Interval Operating hours	Chapter Reference
Inspection, remedial action	as indicated	
4) Fuel system		
Inspect fuel filter for dirt, replace if required.	Inspect before every operation of vehicle	
Inspect fuel screen from the carburetor.	Every 10 hours of operation	
5) Exhaust system		
Inspect exhaust system for sealing and tightness, lubricate with oil to prevent corrosion.	Inspect before every operation of vehicle	
Replace the silencer matting in the exhaust system.	Every 10 hours of operation	
6) Outlet control		
Clean the exhaust valve and check for free movement.	Every 10 hours of operation	
7) Gearbox		
Check the oil level, top up if necessary.	Every 2 hours of operation	
Renew gear oil.	Every 5 hours of operation	
8) Starter drive		
Inspect for wear, replace if necessary.	Every 50 hours of operation (depending on the conditions of use)	
9) Clutch		
Inspect clutch drum needle bearing for wear, replace if necessary.	Every 10 hours of operation	
Clean the sealing groove in the starter gear assy.	Every 10 hours of operation	
10) Engine inspection		
Engine inspection by authorized service center, replace defective parts.	Every 50 hours of operation	

BRP-Rotax
REPAIR MANUAL

NOTES

BRP-Rotax
REPAIR MANUAL

Chapter: Chapter 3
ENGINE

TOPICS IN THIS CHAPTER

System description	2
Preparation for removal.....	3
Removal of the ignition system	3
Removal of the exhaust system	6
Removal of radiator with cap assy.	6
Removal of the fuel line.....	7
Removal of the Bowden cable	8
Removal of the overload clutch.....	8
Removal of the shift mechanism	9
Removal of the engine from kart chassis	10
Positioning the engine on the trestle mounting plate	11
Preparation for installation.....	13
Removing the engine from the trestle mounting plate	13
Installation of the engine on kart chassis	13

Contents This chapter describes the disassembly and assembly of the ROTAX® 125 MAX DD2 evo engine.

SYSTEM DESCRIPTION

Overview

Engine

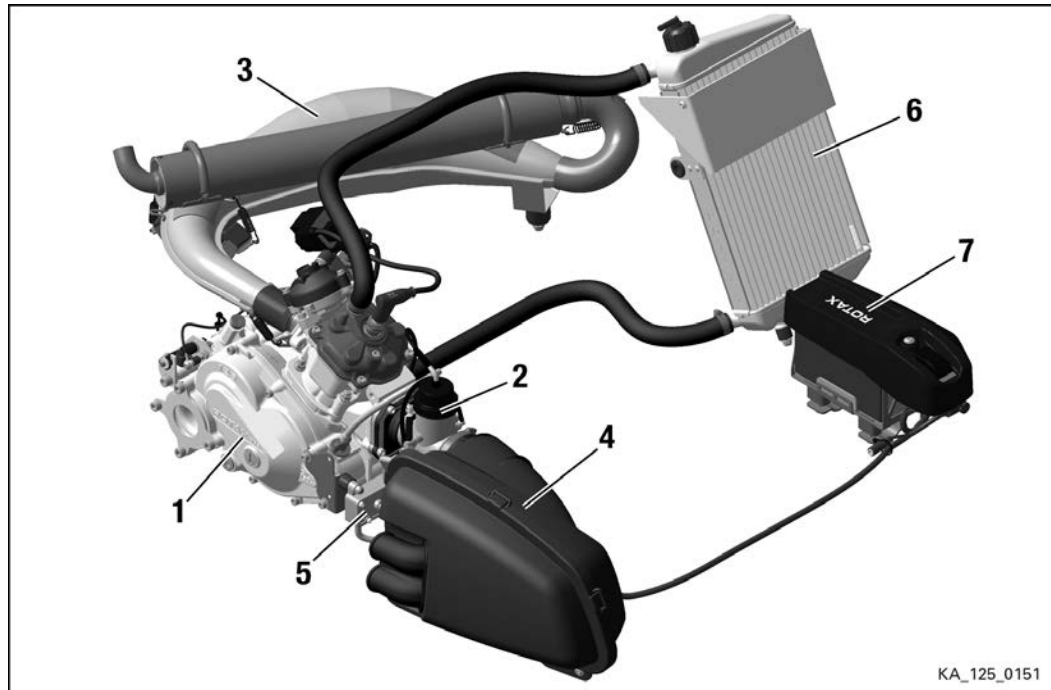

Figure 3.1: Engine components

- | | | | |
|---|------------------------|---|-----------------|
| 1 | Engine | 2 | Carburetor |
| 3 | Exhaust system | 4 | Intake silencer |
| 5 | Fuel pump | 6 | Radiator |
| 7 | Battery mounting + ECU | | |

PREPARATION FOR REMOVAL

Safety instructions

⚠ WARNING

Danger of severe burns and scalds!

Always allow the engine to cool down to ambient temperature before starting any work.

REMOVAL OF THE IGNITION SYSTEM

Safety instructions

⚠ WARNING

Risk of electric shock!

Ignition "OFF" and system grounded! Disconnect negative terminal of battery.

NOTE

When disconnecting the battery be sure to always disconnect the negative terminal before the positive terminal. Remember that when the engine is running the ignition system has a high voltage of 35 kV; the spark plug therefore must not be removed with the engine running.

Instruction

Proceed as follows to disconnect battery. See [Figure: Battery](#).

1. Remove the Allen screw with rounded flange head M6x20 (3) with O-ring 5x2 (2).
2. Remove the battery cover (1).
3. Disconnect the negative battery terminal (5).

BRP-Rotax REPAIR MANUAL

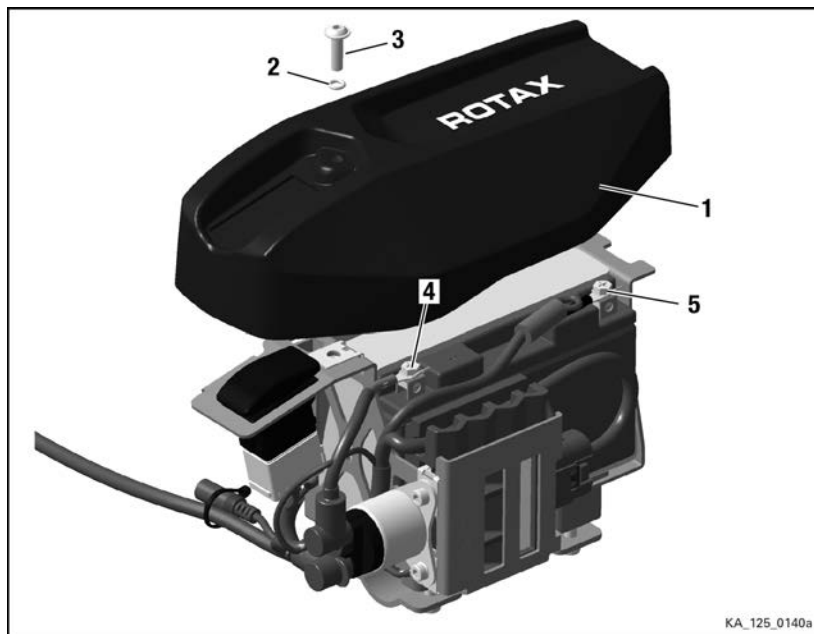

Figure 3.2: Battery

- | | |
|--|-----------------------------|
| 1 Battery cover | 2 O-ring |
| 3 Allen screw with rounded flange head | 4 Positive battery terminal |
| 5 Negative battery terminal | |

Instruction See [Figure: Ignition system](#)

4. Pull the spark plug connector (1) off the spark plug. Minimum removal force 30 N.
5. Remove the cable tie (14).
6. Disconnect the plug connections (6) on the ignition coil (2).
7. Disconnect the plug connection (7) on the solenoid valve (5).
8. Remove the plastic screw M6x25 (12) from the shift contact assy. Loosen the contact wire (11).
9. Loosen 2 Allen screws M6x25 (8) to release the protection shield (9) from the pick up sensor (3).
10. Disconnect the connector (10) for the pick up sensor (3)
11. Disconnect the connector (13) for the starter (4).

BRP-Rotax REPAIR MANUAL

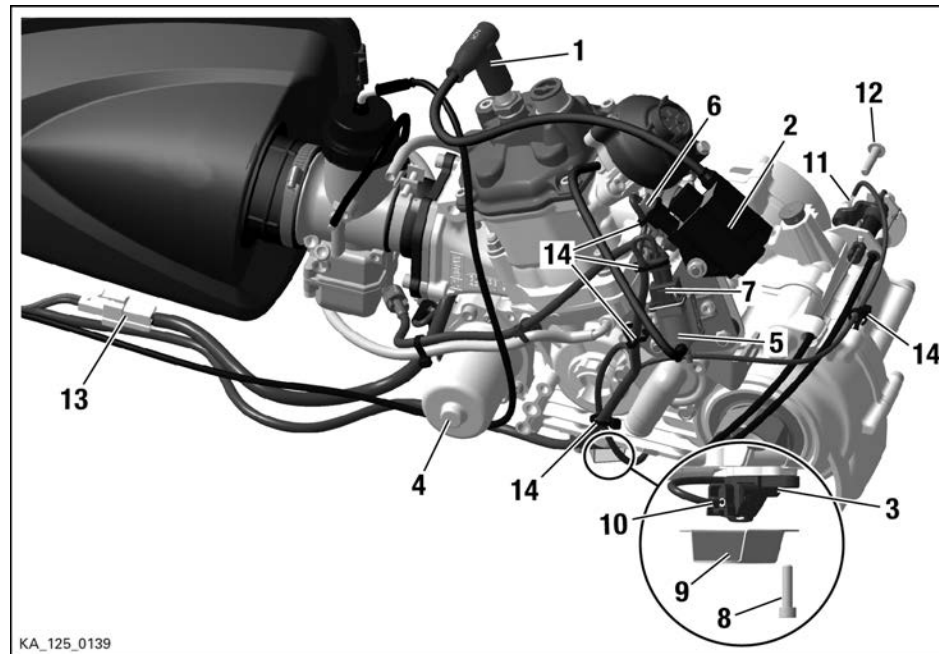

Figure 3.3: Ignition system

- | | |
|---------------------------------|---------------------------|
| 1 Spark plug connector | 2 Ignition coil |
| 3 Crankshaft positioning sensor | 4 Electric starter |
| 5 Solenoid valve | 6 Connector ignition coil |
| 7 Solenoid connector | 8 Allen screw M6x25 |
| 9 Protection shield | 10 CPS connector |
| 11 Contact wire | 12 Plastic screw M6x25 |
| 13 Starter connector | 14 Cable tie |

BRP-Rotax
REPAIR MANUAL

REMOVAL OF THE EXHAUST SYSTEM

General Proceeds follows to dismantle the exhaust system:

Step	Procedure
1	Removal of the exhaust system. See Chapter 9.

REMOVAL OF RADIATOR WITH CAP ASSY.

General Proceeds follows to dismantle the radiator with cap assy.:

Step	Procedure
1	Removal of radiator with cap assy. See Chapter 8.

BRP-Rotax REPAIR MANUAL

REMOVAL OF THE FUEL LINE

Safety instructions

⚠ WARNING

Danger of explosion and ignition!

Overflowing and spoilt gasoline must be absorbed immediately with a binding agent and correctly disposed. Do not work with open flames and sources of ignition. Fuel must not come into contact with hot parts such as engine or exhaust since this may cause a fire!.

Instruction Proceed as follows to remove the fuel line:

1. Pull off fuel line (2) from the fuel pump (1).

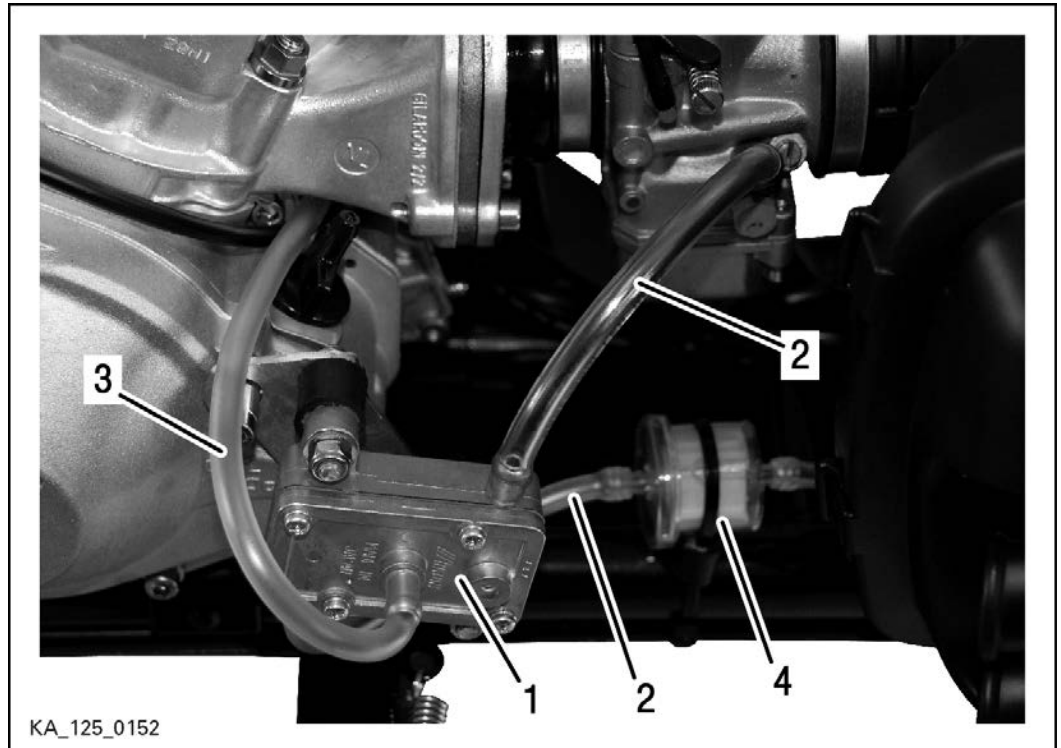

Figure 3.4: Fuel components

- 1 Fuel pump
- 3 Impulse hose

- 2 Fuel line
- 4 Fuel filter

BRP-Rotax REPAIR MANUAL

REMOVAL OF THE BOWDEN CABLE

Instruction Proceed as follows to remove the Bowden cable:

1. Remove the carburetor cover (1).
2. Release the nipple screw from the slide.
3. Disconnect the Bowden cable (2) from the nipple screw (3).

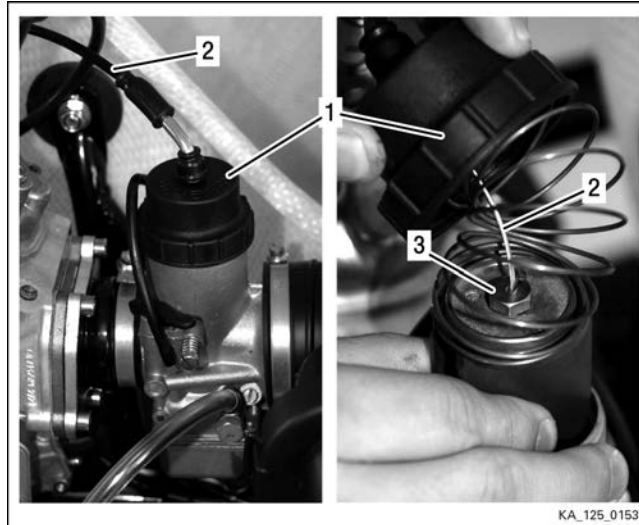

Figure 3.5: Bowden cable

- 1 Carburetor cover
3 Nipple screw

2 Bowden cable

REMOVAL OF THE OVERLOAD CLUTCH

See [Figure: Overload clutch](#).

1. Release the wheel-side clamping ring (2).
2. Loosen the 6 Allen screws M5x25 (4) evenly and remove the coupling flange assy (1).

BRP-Rotax REPAIR MANUAL

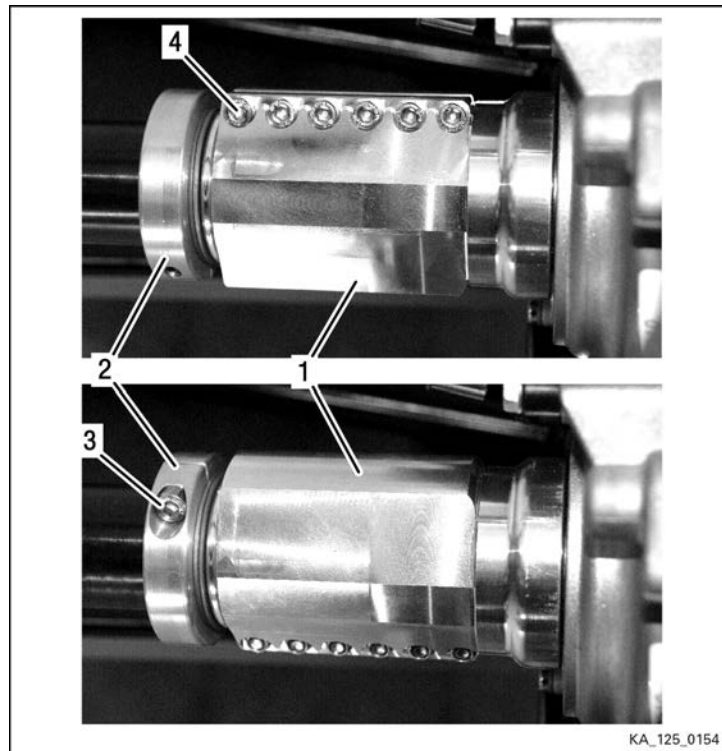

Figure 3.6: Overload clutch

- | | | | |
|---|------------------------------|---|--------------------------|
| 1 | <i>Coupling flange assy.</i> | 2 | <i>Clamping ring</i> |
| 3 | <i>Allen screw M6x25</i> | 4 | <i>Allen screw M5x25</i> |

REMOVAL OF THE SHIFT MECHANISM

See [Figure: Shift mechanism](#).

1. Push out the locating pin and release the bowden cables (1) from the shift contact guidance (2).
2. Remove spring-loaded shift actuator.
3. Loosen the hex screw M6x12 on the retaining plate (5) and remove along with the spring washer (6).
4. Set the thrust washers and spiral spring (4) to one side.

BRP-Rotax REPAIR MANUAL

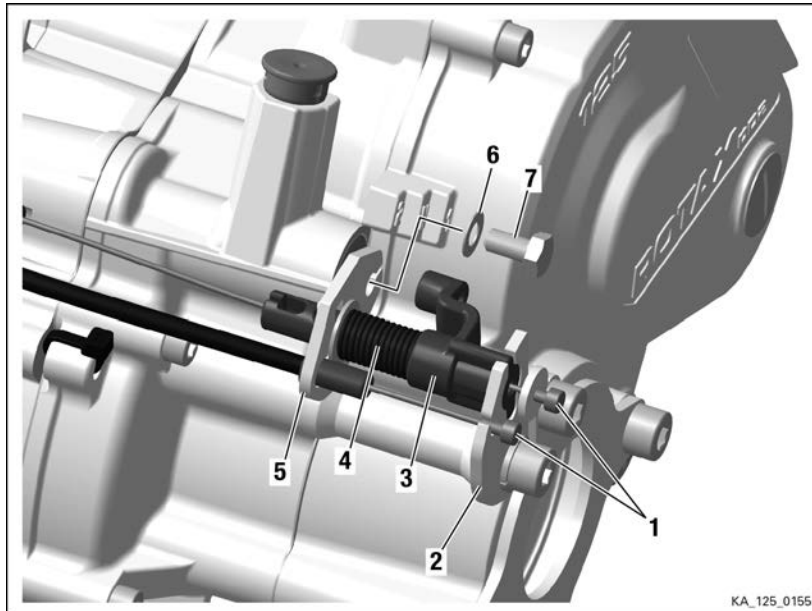

Figure 3.7: Shift mechanism

- | | |
|-----------------------|--------------------------|
| 1 Cable bowden assy. | 2 Shift contact guidance |
| 3 Shift contact assy. | 4 Compression spring |
| 5 Retaining plate | 6 Spring washer B6 |
| 7 Hex. screw M6x12 | |

REMOVAL OF THE ENGINE FROM KART CHASSIS

General

Loosen the engine from chassis following the chassis manufacturer's instruction. Remove both screws (engine clamps) and disconnect all cables.

NOTE

*The engine **must not** be removed from the chassis to repair the following parts:*

- Centrifugal clutch
- Cylinder with combustion chamber insert and cylinder head cover
- Exhaust valve
- Reed valve
- Piston
- Starter
- Oil Service

BRP-Rotax REPAIR MANUAL

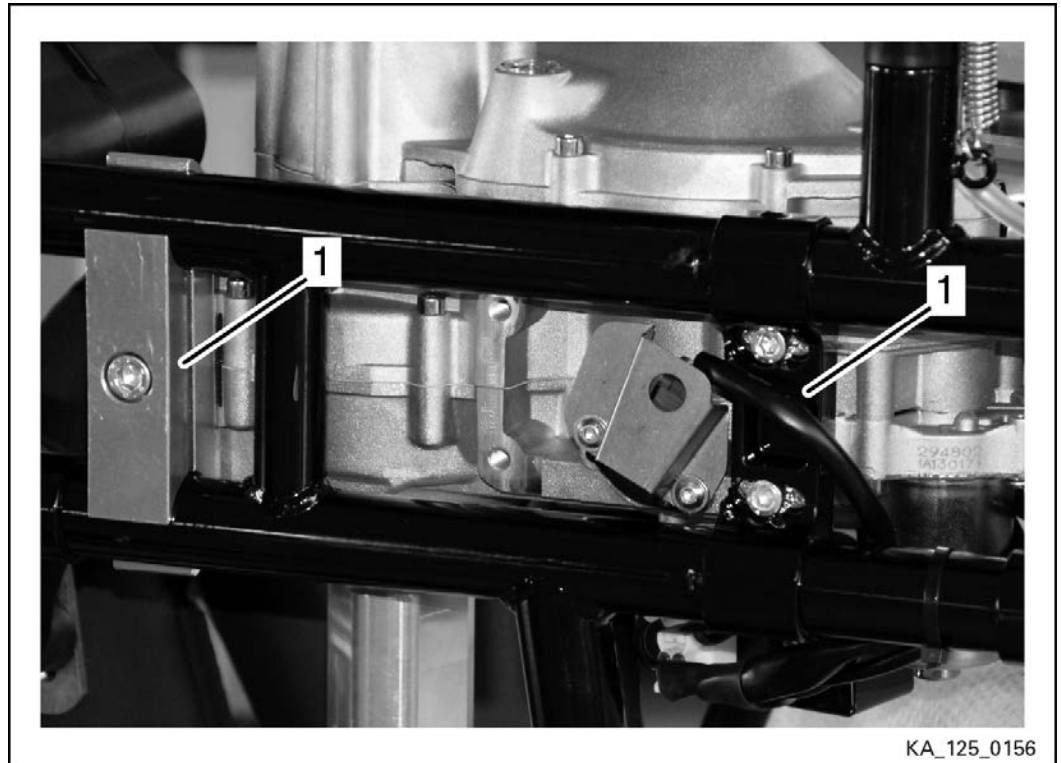

Figure 3.8: Engine clamp (Illustration similar)

1 Engine clamp

POSITIONING THE ENGINE ON THE TRESTLE MOUNTING PLATE

General

ATTENTION

Do not use flammable liquids and aggressive cleaning agents to clean the engine.

ENVIRONMENTAL NOTE

Generally comply with standard rules for handling of chemicals. Dispose of chemicals as per local environmental regulations.
Cleaning the engine removes fuel and oil residues and other environmentally damaging substances. The waste liquid must be caught and disposed in an environmentally compatible method.

BRP-Rotax REPAIR MANUAL

Special tools

The following special tools and equipment are required:

Part no.	Description	Field of application
877390	Trestle mounting plate (trestle support)	Engine
676052	Fixing plate for engine	Engine

Instructions

Proceed as follows to position the engine on the trestle mounting plate:

1. Engine cleaning.
2. Unscrew the base plate from the engine, position the engine on the trestle mounting plate, and fix it securely with the 4 fixing screws.

PREPARATION FOR INSTALLATION

Safety instructions

ATTENTION

Clean and inspect disassembled parts and assemble them in accordance with the instructions. All screws and nuts must always be clean. Inspect surfaces and threads for damage. In case of doubt use new screws and nuts.

REMOVING THE ENGINE FROM THE TRESTLE MOUNTING PLATE

Instructions Proceed as follows to remove the engine from the trestle mounting plate:

1. The engine is removed in reverse order of positioning.
See also Chapter [Positioning the engine on the trestle mounting plate](#).

INSTALLATION OF THE ENGINE ON KART CHASSIS

Safety instructions

⚠ WARNING

Non-compliance can result in serious injuries or death!

Before installing the engine on the chassis the Installation and Operators Manual for the engine and the installation instructions of the chassis manufacturer must be read and understood.

For the Installation of the engine on kart chassis, see latest current Installation and Operators Manual of the engine type 125 MAX DD2.

BRP-Rotax
REPAIR MANUAL

NOTES

Chapter: Chapter 4
CYLINDER COMPONENTS

TOPICS IN THIS CHAPTER

System description	2
Cylinder removal	3
Disassembling the cylinder	5
Removal of the spark plug	5
Removal of the cylinder head cover	5
Removal of the thermostat	6
Removal of the combustion chamber insert	6
Removal of the exhaust socket	7
Removal of the intake socket and reed valve	8
Removal of the exhaust valve	8
Removal of the piston	10
Cylinder components inspection	11
Inspection of cylinder components	11
Inspection of piston and piston ring	12
Inspection of the Piston diameter	13
Inspection of the Piston and cylinder sizing	14
Inspection of the Piston pin, circlip	15
Inspection of the spark plug	15
Inspection of the cylinder head cover	17
Inspection of the combustion chamber insert	17
Inspection of the exhaust socket	18
Inspection of the carburetor flange and reed valve	19
Inspection of exhaust valve	20
Cylinder components installation	21
Installation of exhaust valve	21
Installation of exhaust valve, gasket, valve rod housing	22
Installation of the exhaust valve piston	22
Installation of piston	24
Installation of the cylinder	25
Installation of the exhaust socket	26
Installation of the carburetor flange and reed valve	27
Installation of combustion chamber insert	29
Installation of cylinder head cover	29
Inspection and adjustment of squish gap	31
Installation of spark plug	34

Contents This chapter describes the disassembly and assembly of the cylinder components of the ROTAX® 125 MAX DD2 evo engine. The description is divided into sections.

BRP-Rotax
REPAIR MANUAL

SYSTEM DESCRIPTION

Overview

Position on the engine

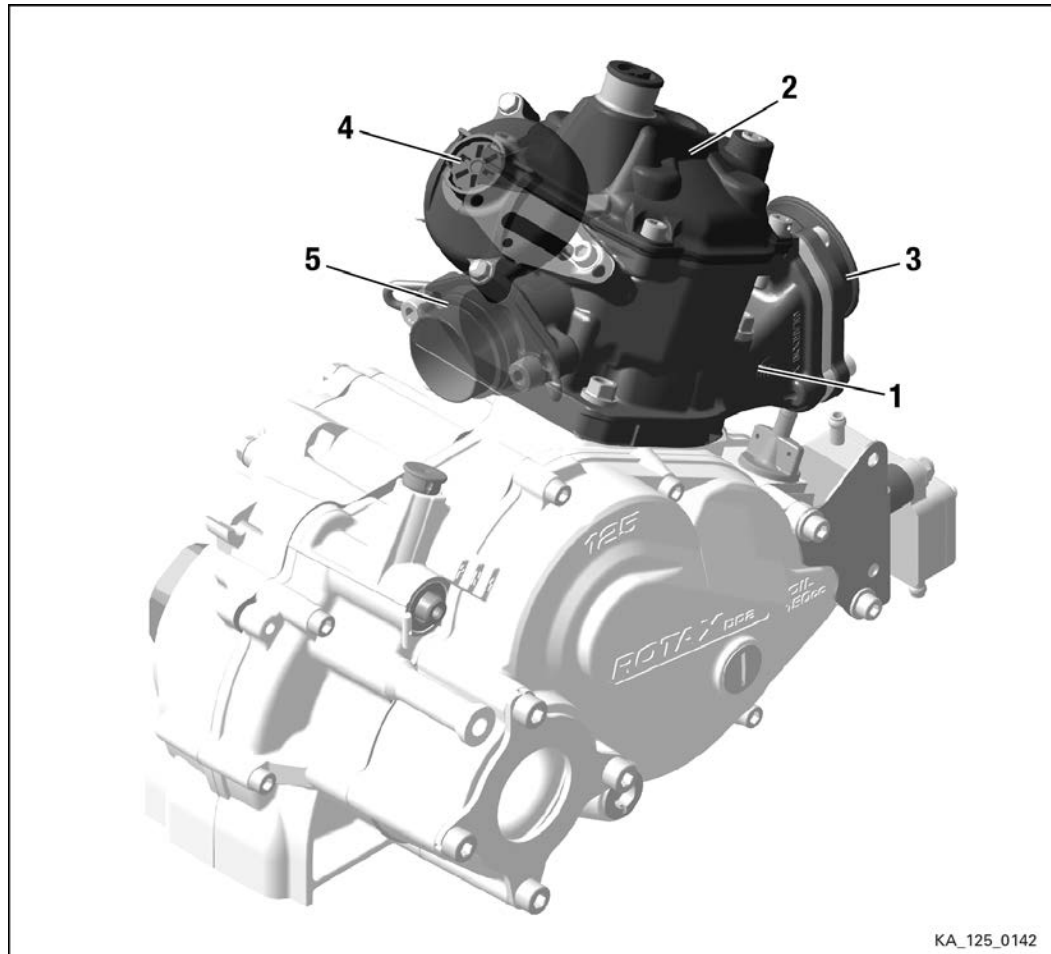

KA_125_0142

Figure 4.1

- | | | | |
|---|----------------------|---|---------------------|
| 1 | Cylinder | 2 | Cylinder head cover |
| 3 | Intake socket | 4 | E-Rave cover |
| 5 | Exhaust socket assy. | | |

CYLINDER REMOVAL

General

⚠ WARNING

Danger of severe burns and scalds! Always allow the engine to cool down to ambient temperature before starting any work.

NOTE

If only the components in the crankcase are to be replaced or inspected, then the cylinder can be removed completely together with the following parts:

- *Cylinder head cover*
- *Intake socket*
- *E-Rave*
- *Exhaust socket assy.*
- *Spark plug*

The exhaust socket, carburetor flange and exhaust valve remain installed.

Preparation

The following preparation is required before removal:

- Removal of the radiator and radiator hoses. See also Chapter 3.
- Removal of the carburetor and intake silencer. See also Chapter 6.
- Removal of the exhaust system. See also Chapter 8.

Instructions

ATTENTION

Drain the coolant from the cylinder and invert the engine to prevent entry of water into the crankcase.

ATTENTION

Do not damage the piston, piston ring and wall when dismantling these components.

Special tools

The following special tools and equipment are required:

Part no.	Description	Field of application
676110	Socket set	Cylinder

BRP-Rotax REPAIR MANUAL

Instruction See [Figure: Cylinder](#). Proceed as follows to remove the cylinder:

1. Remove the cylinder with the socket set by unscrewing the four M8 collar nuts from the crankcase.
2. Remove the cylinder (1) from the crankcase.
3. Remove the cylinder base gasket (2).

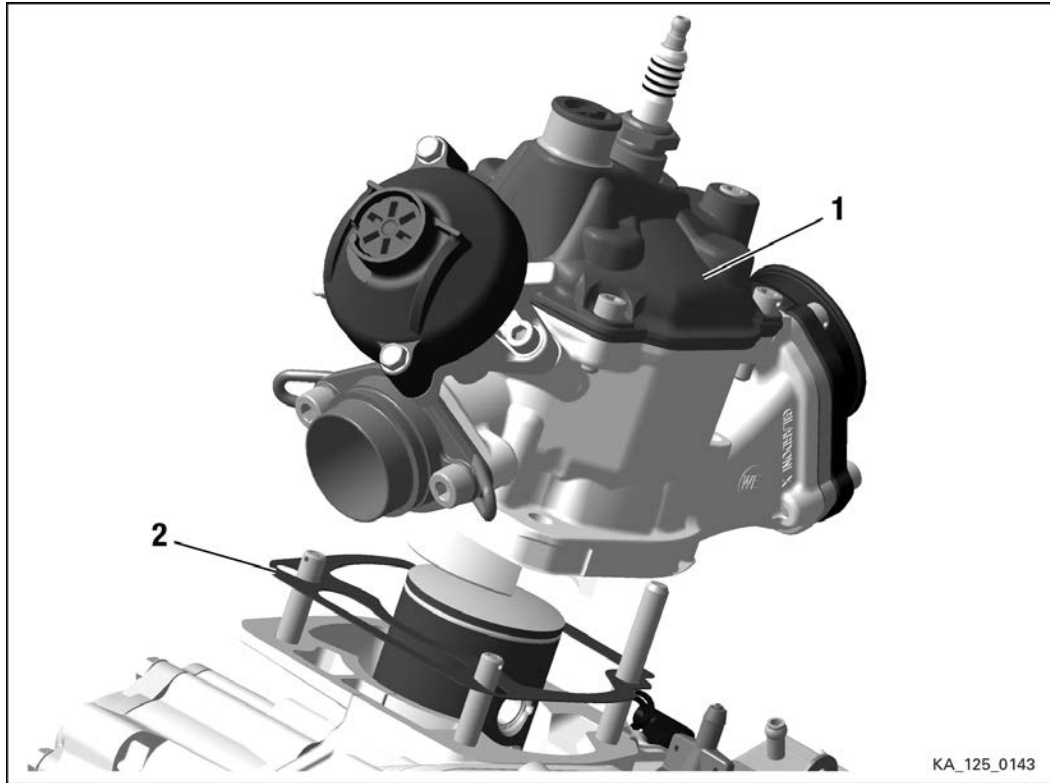

Figure 4.2: Cylinder

1 *Cylinder*

2 *Gasket*

DISASSEMBLING THE CYLINDER

General

NOTE

If only the components in the crankcase are to be replaced or inspected, then the cylinder can be removed complete with the peripheral components. The exhaust socket, carburetor flange and exhaust valve remain installed. See Chapter: Removal of the shift mechanism.

Proceed as follows to disassemble the cylinder:

REMOVAL OF THE SPARK PLUG

Instruction

1. Remove the spark plug connector.
2. Remove the spark plug with the spark plug socket.

REMOVAL OF THE CYLINDER HEAD COVER

Instruction

See [Figure: Cylinder head cover](#).

1. Remove the cylinder head cover (1) by removing the 3 Allen screws (M6x25) (3) and 1 Allen screw M6x16 (4) from the cylinder.
2. Remove the cylinder head together with the gasket.

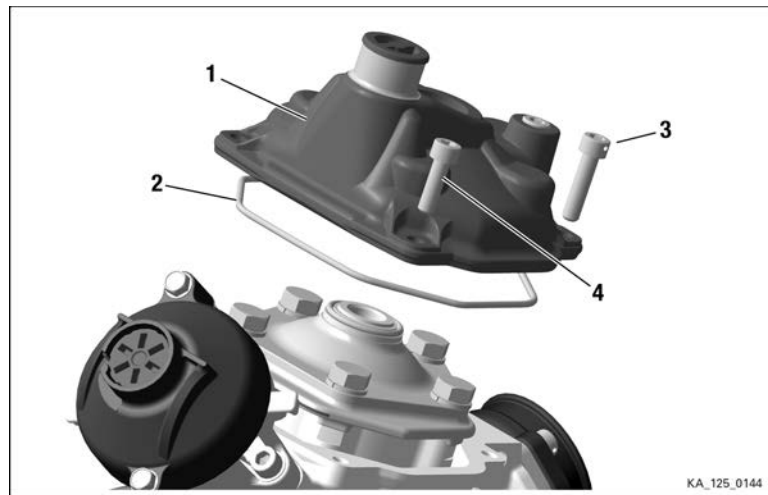

Figure 4.3: Cylinder head cover

1 Cylinder head cover

2 O-ring 105x2.5

3 Allen screw M6x25

4 Allen screw M6x16

BRP-Rotax REPAIR MANUAL

REMOVAL OF THE THERMOSTAT

Instruction See [Figure: Thermostat.](#)

1. Remove the coolant thermostat from the cylinder head cover (1) by removing the 2 TAPTITE screws M4x8 (6) on the thermostat retaining bracket (5).
2. Remove the compression spring (4).
3. Remove the thermostat (2) from the thermostat holder (3).

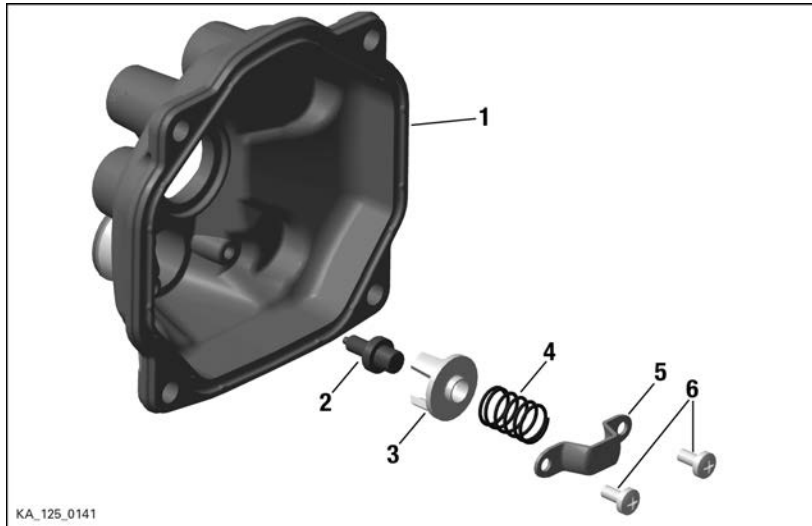

Figure 4.4: Thermostat

- | | | | |
|---|------------------------------|---|-------------------------------|
| 1 | Cylinder head cover | 2 | Thermostat, 45 Degree celcius |
| 3 | Thermostat holder | 4 | Compression spring |
| 5 | Thermostat retaining bracket | 6 | TAPTITE screw M4x8 |

REMOVAL OF THE COMBUSTION CHAMBER INSERT

Instruction See [Figure: Combustion chamber insert.](#)

1. Remove the combustion chamber insert (1) by unscrewing the 5 Hex screws M8x30 (4) with the lock washer (5) crosswise.
2. Lift away the combustion chamber insert with lower (2) and upper O-rings (3).

BRP-Rotax REPAIR MANUAL

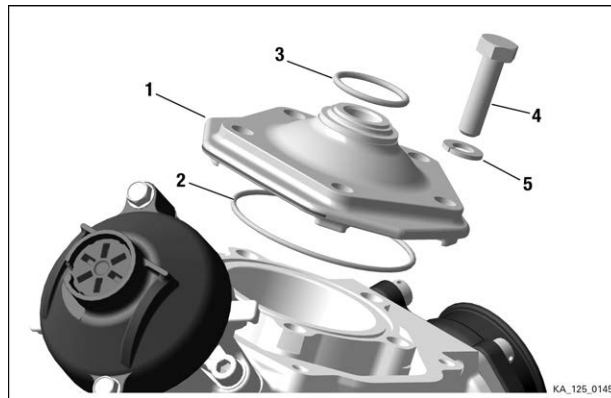

Figure 4.5: Combustion chamber insert

- | | | | |
|---|---------------------------|---|------------------|
| 1 | Combustion chamber insert | 2 | O-ring 64x2 |
| 3 | O-ring 23.3x2.4 | 4 | Hex. screw M8x30 |
| 5 | Lock washer A8 | | |

REMOVAL OF THE EXHAUST SOCKET

Instruction See [Figure: Exhaust socket](#).

1. Remove the exhaust socket (1) from the cylinder (5) by unscrewing the 2 Allen. screws (3).
2. Remove the gasket (4).

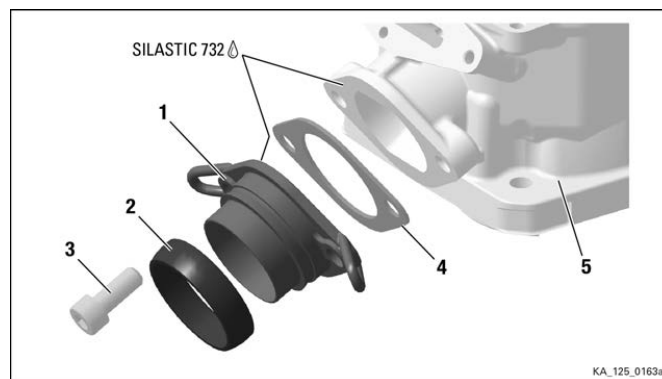

Figure 4.6: Exhaust socket

- | | | | |
|---|-------------------|---|----------------|
| 1 | Exhaust socket | 2 | Exhaust gasket |
| 3 | Allen screw M8x20 | 4 | Gasket |
| 5 | Cylinder | | |

BRP-Rotax REPAIR MANUAL

REMOVAL OF THE INTAKE SOCKET AND REED VALVE

Instruction See [Figure: Intake socket, Reef valve](#).

1. Remove the intake socket (6) with the 5 Allen screws M6x25 (4)(5).
2. Remove the reed valve (7) and gasket (8) from the cylinder.

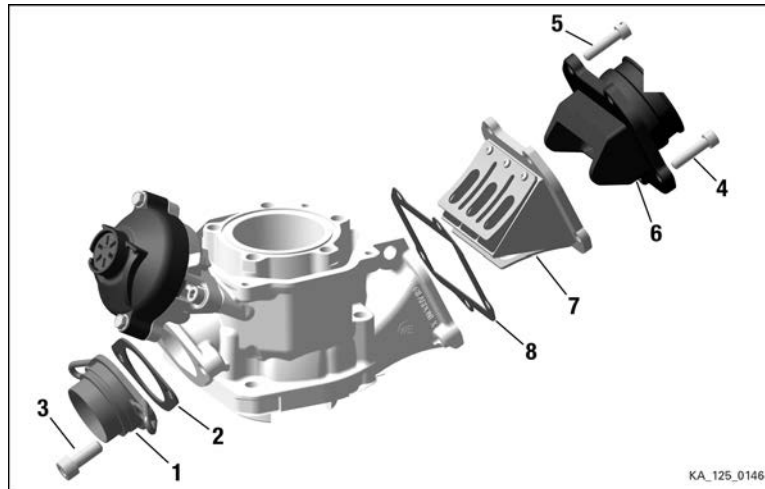

Figure 4.7: Intake socket, Reed valve

- | | |
|------------------------|--|
| 1 Exhaust socket assy. | 2 Gasket |
| 3 Hex. screw M8x20 | 4 Allen screw M6x25 with hole for sealing the engine |
| 5 Allen screw M6x25 | 6 Intake socket |
| 7 Reed valve assy. | 8 Gasket |

REMOVAL OF THE EXHAUST VALVE

General The engine has an electronically controlled magnet valve which is opening and closing at a certain rpm defined by the ECU. The opening rpm can be set to following:

- 9100 rpm if the additional ground cable on the battery box is disconnected.
- 8800 rpm if the additional ground cable is connected to the battery box.

The closed valve improves the performance in the low and mid range. In the upper rpm range the valve opens to reduce flow resistance of the exhaust gases. For a detailed explanation please visit our website and watch our animated video that will explain the function in detail: <https://www.rotax-kart.com/de/Community/Videos/Rotax-125-MAX-evo-Engines/124-Rotax-E-RAVE>

Instruction See [Figure: Exhaust valve](#).
Proceed as follows to remove the exhaust valve:

BRP-Rotax REPAIR MANUAL

1. Release the adjustment screw (1) with the O-ring (2)
2. Remove the 2 TAPTITE screws M5x25 (3).
3. Remove the valve cover (4) and the compression spring (5).
4. Lift away the outer hose spring (6).
5. Unscrew the exhaust valve piston (7).
6. Remove the inner hose spring (9) from the bellows (8), push out the valve bellows from the valve piston.
7. Release the valve rod housing (10) from the cylinder with the 2 Allen screws M6x25 (11) with spring washers (12). Remove the gasket (13).
8. Remove the exhaust valve (14) with O-ring (16) and stud (15).

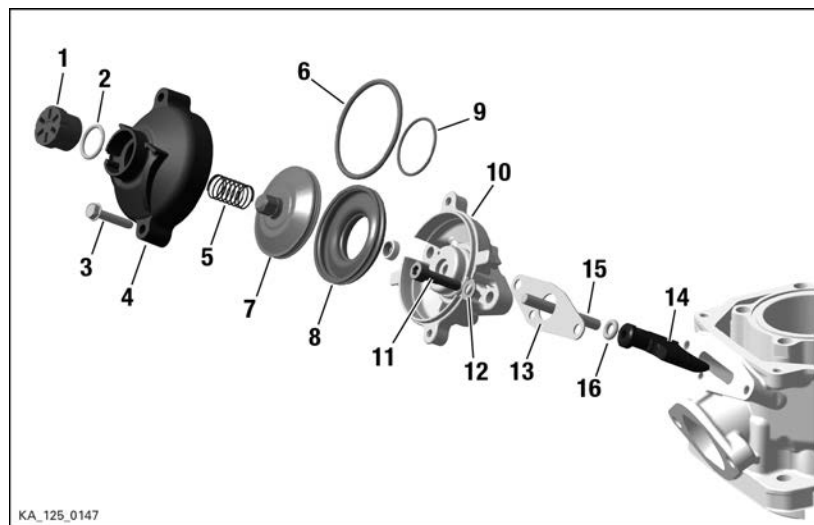

Figure 4.8: Exhaust valve

- | | | | |
|----|--------------------------------|----|--------------------------|
| 1 | Adjustment screw | 2 | O-ring 15.9–2.3 |
| 3 | TAPTITE screw M5x25 | 4 | Valve cover |
| 5 | Compression spring 48.5/0.8 mm | 6 | Hose spring 134–3.0–0.65 |
| 7 | Exhaust valve piston | 8 | Bellow |
| 9 | Hose spring 70–1.7–0.3 | 10 | Valve rod housing assy. |
| 11 | Allen screw M6x25 | 12 | Spring washer B6 |
| 13 | Gasket | 14 | Exhaust valve |
| 15 | Stud M6x52.5 | 16 | O-ring 6x2.5 RED |

BRP-Rotax REPAIR MANUAL

REMOVAL OF THE PISTON

General See [Figure: piston](#).

ATTENTION

In order to protect the piston pin circlip from unintentional loss, a suitable clean cloth should be used to cover the open cylinder bore in the crankcase.

ATTENTION

Always support the piston with the hand in order to avoid a bending moment or damage of the surface.

Special tools

The following special tools and equipment are required:

Part no.	Description	Field of application
676035	Insertion tool	Piston
976380	Circlip puller	Circlip

Instructions

Proceed as follows to remove the piston:

1. Pull out the circlip (2) with the circlip puller (1). Use safety goggles to protect your eyes!
2. Press the piston pin (4) out of the piston with the point of the special tool (3).

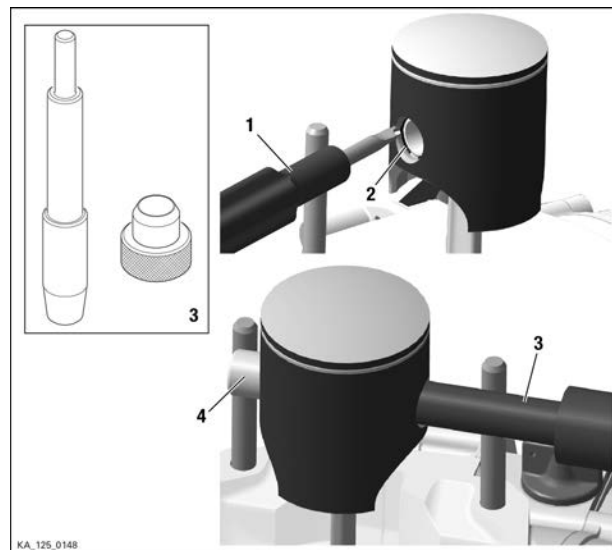

Figure 4.9: Piston

1 Circlip puller

2 Circlip

3 Special tool part no. 676035

4 Piston pin

CYLINDER COMPONENTS INSPECTION

General

ATTENTION

Components, which have reached or exceeded their wear limits, must be replaced. Components, which are found to be defective in the context of the visual inspection and might influence the engine's performance, must also be replaced.

INSPECTION OF CYLINDER COMPONENTS

Instructions See [Figure: Cylinder](#).

Preparation The following preparation is required before removal.

1. Remove lime deposits (1) from the water cooling of the cylinder.
2. Clean combustion residues from the exhaust valve and slider duct (2).
3. Clean O-ring groove (3).
4. Inspect all threads.
5. All sealing surfaces must be clean and smooth.
6. Inspect the cylinder bore for abnormal wear.
7. Inspect the impulse bore (4).

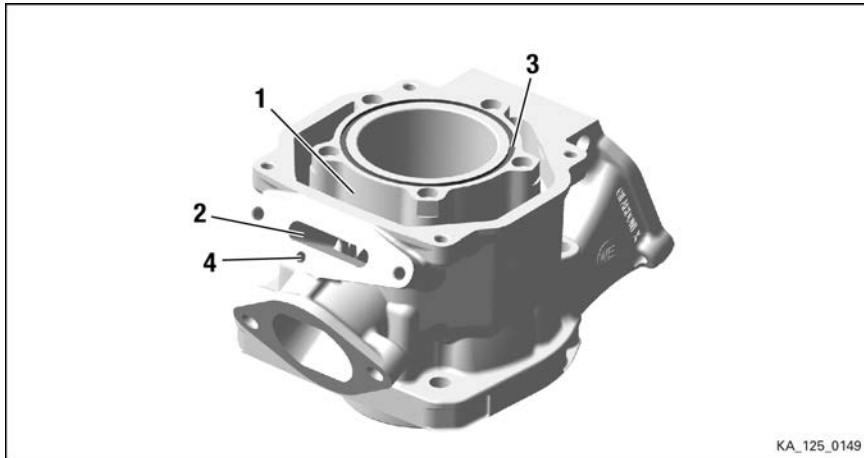

Figure 4.10: Cylinder

1 Water duct

2 Exhaust valve port

3 Groove for O-ring

4 Impulse bore

BRP-Rotax REPAIR MANUAL

INSPECTION OF PISTON AND PISTON RING

Instructions See [Figure: Piston and piston ring](#).

1. Inspect the piston for cracks and signs of piston seizure.
2. Inspect the bore of the piston pin for damage and wear.
3. Inspect the piston pin ring groove for defects.
4. Check free of movement of the piston ring in the ring groove.

NOTE

If carbon prevents free movement of the piston ring, the ring groove can be cleaned out with a discarded piston ring.

5. Measure the piston ring clearance in the ring groove with a feeler gauge (1).

NOTE

If the piston ring clearance has reached the wear limit of 0.1 mm, the piston must be replaced.

6. Remove the piston ring from the piston, insert it approx. 10 mm from top into the cylinder (use the piston to do so) and check ring-end gap by means of a feeler gauge.
7. Measure clearance with a feeler gauge.

NOTE

If the wear limit of 0.8 mm has been reached the piston ring must be replaced.

8. Check the piston ring locking pin for wear.

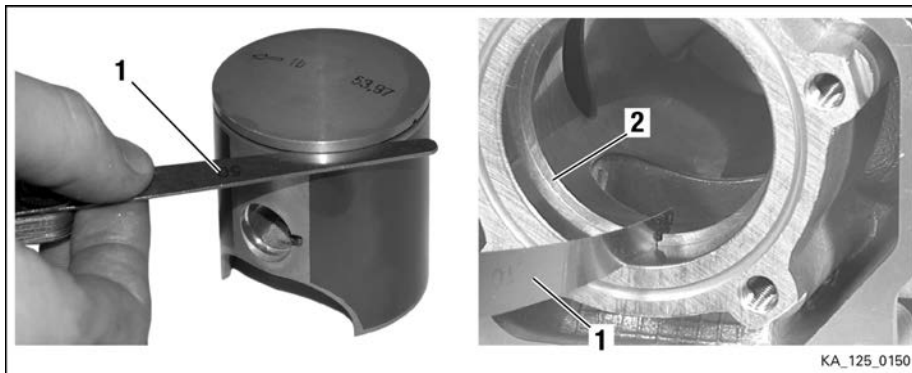

Figure 4.11: Piston and piston ring

1 Feeler gauge

2 Piston ring

BRP-Rotax REPAIR MANUAL

INSPECTION OF THE PISTON DIAMETER

Instructions

1. Measure the piston diameter with a micrometer (1). Conditions of measurement: room temperature = 20 °C, measuring point 20 mm from the lower edge of the piston, perpendicular to the piston pin axis.
2. Determine the piston to cylinder clearance. The wear limit is 0.08 mm.

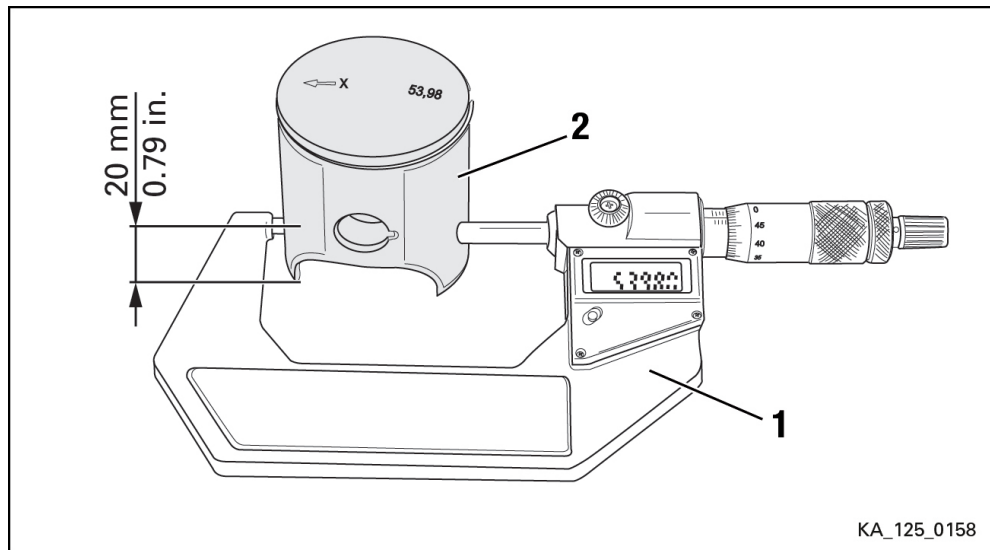

Figure 1.12: Piston diameter

1 Micrometer

BRP-Rotax REPAIR MANUAL

INSPECTION OF THE PISTON AND CYLINDER SIZING

General

NOTE

Every new piston has the size classification and a production letter printed on the top of the piston (piston crown).

NOTE

Every new cylinder has the size classification stamped on the upper sealing surface.

Measuring the cylinder diameter:

1. Measure the cylinder diameter 10 mm below the upper edge of the cylinder. This dimension indicates the selection of the matching piston. If the dimension has reached the wear limit of 54.045 mm, the cylinder must be replaced.
2. Measure the piston diameter as described in chapter 4 "Inspection of the piston diameter" and install a piston to match the required clearance at 0.060 mm +/- 0.005 mm between piston and cylinder.

Cylinder classification

Cylinder labeling	Cylinder dimension
"A"	54.000 - 54.010 mm
"AB"	54.010 - 54.015 mm
"B"	54.015 - 54.025 mm

Piston classification "f"

Piston labeling	Tolerance field (mm)	Minimum dimension (mm)	Maximum dimension (mm)
"f" 53.95	+0.005 / -0.025 mm	53.925	53.955
"f" 53.96	+0.005 / -0.025 mm	53.935	53.965
"f" 53.97	+0.005 / -0.025 mm	53.945	53.975
"f" 53.98	+0.005 / -0.025 mm	53.955	53.985
"f" 53.99	+0.005 / -0.025 mm	53.965	53.995

BRP-Rotax REPAIR MANUAL

Piston classification "h"

Piston labeling	Tolerance field (mm)	Minimum dimension (mm)	Maximum dimension (mm)
"h" 53.94	+0.015 / -0.015 mm	53.925	53.955
"h" 53.95	+0.015 / -0.015 mm	53.935	53.965
"h" 53.96	+0.015 / -0.015 mm	53.945	53.975
"h" 53.97	+0.015 / -0.015 mm	53.955	53.985
"h" 53.98	+0.015 / -0.015 mm	53.965	53.995

INSPECTION OF THE PISTON PIN, CIRCLIP

Instructions See [Figure: Piston pin, circlip](#).

1. Inspect the piston pin (1) for wear and discoloration.
2. Check the needle cage (2) for cracks and abrasion.
3. The circlips (3) are replaced at every repair. Notice the position of the circlip.

NOTE

Direction of circlips is up or downside direction.

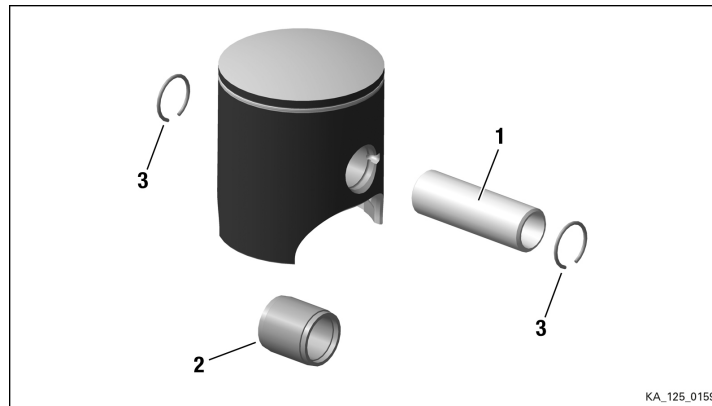

Figure 1.13: Piston pin, circlip

1 Piston pin

2 Needle cage

3 Circlip

BRP-Rotax REPAIR MANUAL

INSPECTION OF THE SPARK PLUG

Instructions See [Figure: Spark plug](#).

1. Inspect spark plug connector for cracks, burn-off, dampness and fouling.
2. Visual inspection of the spark plug for carbonization, oil fouling and discoloration of the electrode.
 - Pos. 1 = normal
 - Pos. 2 = fouled
 - Pos. 3 = insulator breakage
 - Pos. 4 = melted electrode
 - Pos. 5 = oil carbon / deposits
3. Check the electrode gap of the spark plug with a feeler gauge and adjust if required to $s = 0.45 \text{ mm}$ to 0.7 mm .

ATTENTION

Pay attention to the electrode gap, mentioned in the technical regulation! Bending the electrode can cause damage or misfire.

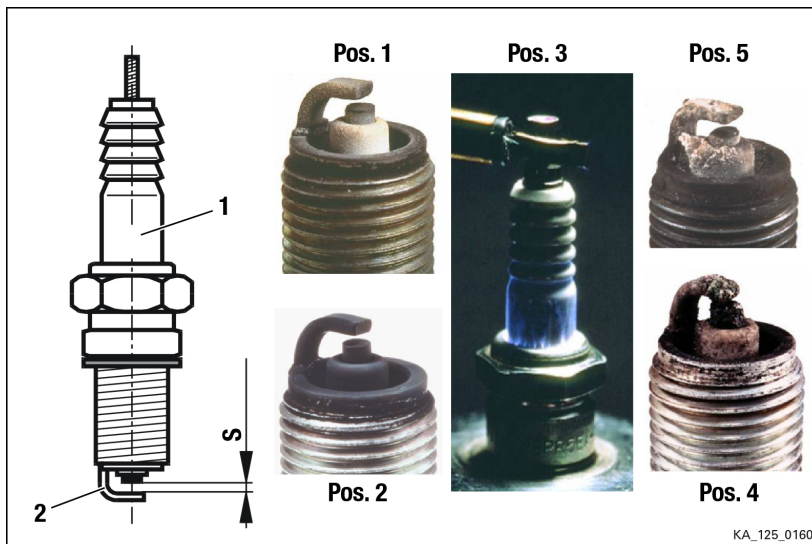

Figure 1.14: Spark plug

1 Spark plug

2 Electrode

BRP-Rotax REPAIR MANUAL

INSPECTION OF THE CYLINDER HEAD COVER

Instructions See [Figure: Cylinder head cover](#).

1. Inspect cylinder head cover for cracks (visual inspection).
2. Inspect the contact surfaces of the two O-rings (1 and 2) for good condition (max. depth of wear 0.05 mm).

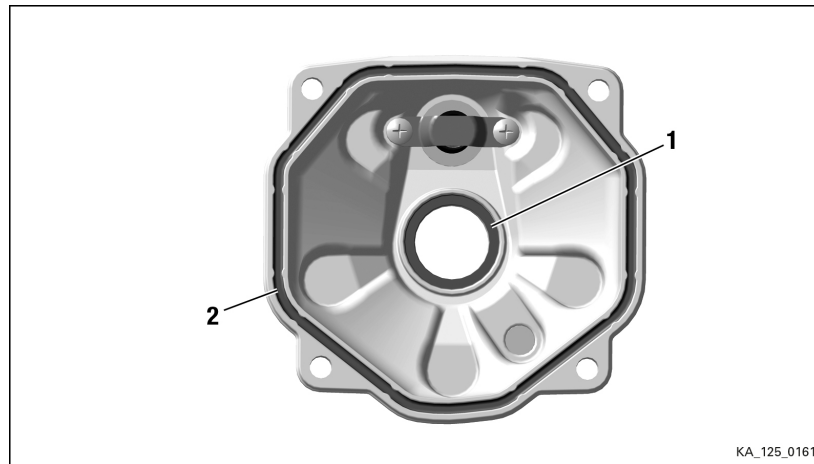

Figure 1.15: Cylinder head cover

1, 2 O-ring contact area

INSPECTION OF THE COMBUSTION CHAMBER INSERT

Instructions See [Figure: Combustion chamber insert](#).

NOTE

The sealing area of the combustion chamber insert is slightly tapered from \varnothing 63 mm.

1. Clean combustion residues and lime deposits from the outer area (1) of the combustion chamber.
2. Inspect combustion chamber insert for cracks (visual inspection).
3. Make sure that spark plug thread (3) is in good condition.
4. Inspect sealing surfaces for flatness and damage.

BRP-Rotax REPAIR MANUAL

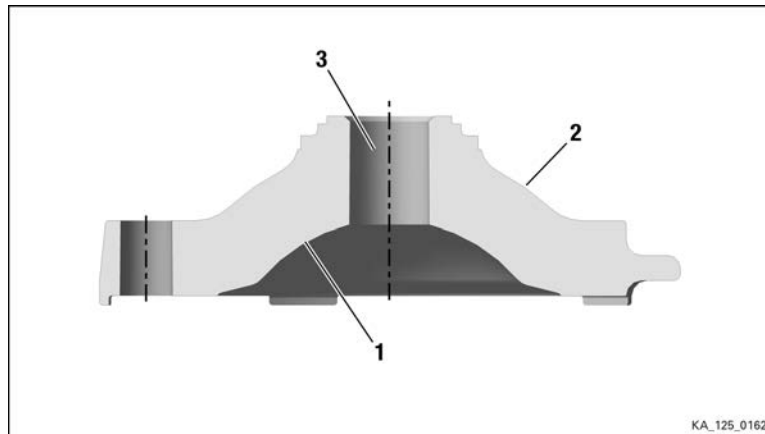

Figure 4.16: Combustion chamber insert

- | | | | |
|---|--------------------|---|--------------|
| 1 | Combustion chamber | 2 | Outside area |
| 3 | Spark plug thread | | |

INSPECTION OF THE EXHAUST SOCKET

Instructions See [Figure: Exhaust socket](#).

1. Inspect the exhaust socket for damage or deformation.
2. Inspect exhaust gasket (2) for wear and replace if applicable.

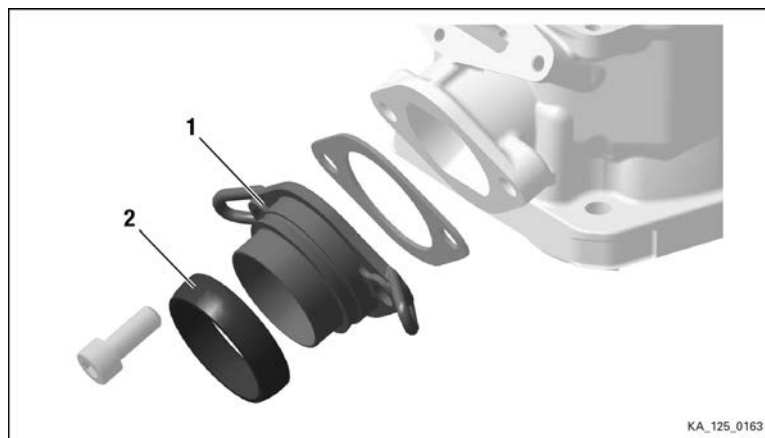

Figure 4.17: Exhaust socket

- | | | | |
|---|-----------------------|---|----------------|
| 1 | Exhaust socket (ball) | 2 | Exhaust gasket |
|---|-----------------------|---|----------------|

BRP-Rotax REPAIR MANUAL

INSPECTION OF THE CARBURETOR FLANGE AND REED VALVE

General

ATTENTION

The reed petal should be completely on the valve guide with a little initial tension (a gap should not be visible when held against the light. If applicable adjust reed valves more precisely by releasing the tightening torque of the screws.

Instructions See [Figure: Carburetor port and valve guide](#).

1. Inspect rubber lining of reed valves (1) for perishing (if applicable replace complete reed valve).
2. Check the two reed petal (2) for cracks or damage.
3. Check the oval head screw M3x6 (3) for secure seating. (LOCTITE 648 Tightening torque 1.5–2 Nm (13-18 in.lb)).
4. Inspect carburetor flange (4) for cracks, porosity or swelling and replace if applicable.

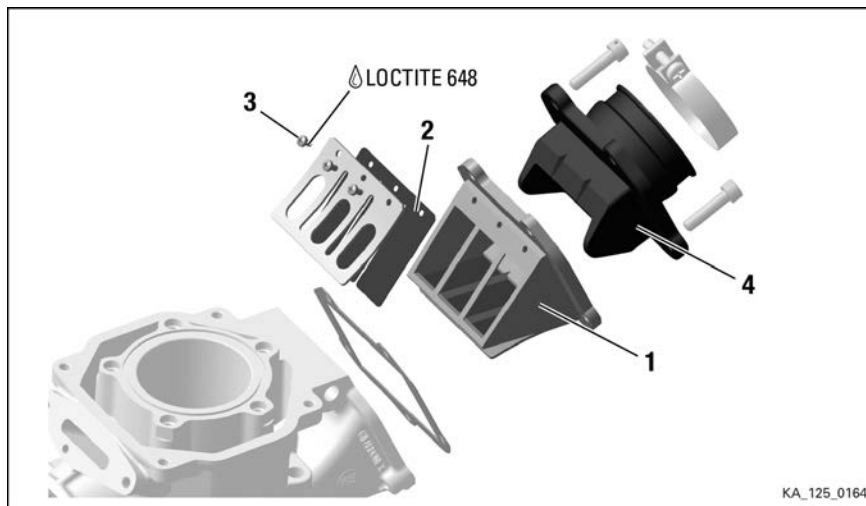

Figure 4.18: Carburetor port and valve guide

1 Reed valve assy.

2 Reed petal

3 Oval head screw M3x6

4 Intake socket

BRP-Rotax REPAIR MANUAL

INSPECTION OF EXHAUST VALVE

See [Figure: Exhaust valve](#).

1. Clean oil or oil deposits from all parts with a suitable cleaning agent.
2. Check the smooth movement of the exhaust valve (1) in the cylinder, if applicable remove carbon deposits on the outlet valve and in the cylinder.
3. Inspect condition of O-ring (2).
4. Check that the impulse bore in the valve rod housing (3) is open and check the oil seal (4).
5. Inspect bellows (5) for cracks or porous areas and replace if applicable.
6. Inspect exhaust valve piston (6) for cracks or deformation by caused overheating and replace if applicable.

NOTE

Overheating may be caused by leaks.

7. Inspect valve cover for cracks (7) or deformation caused by overheating.

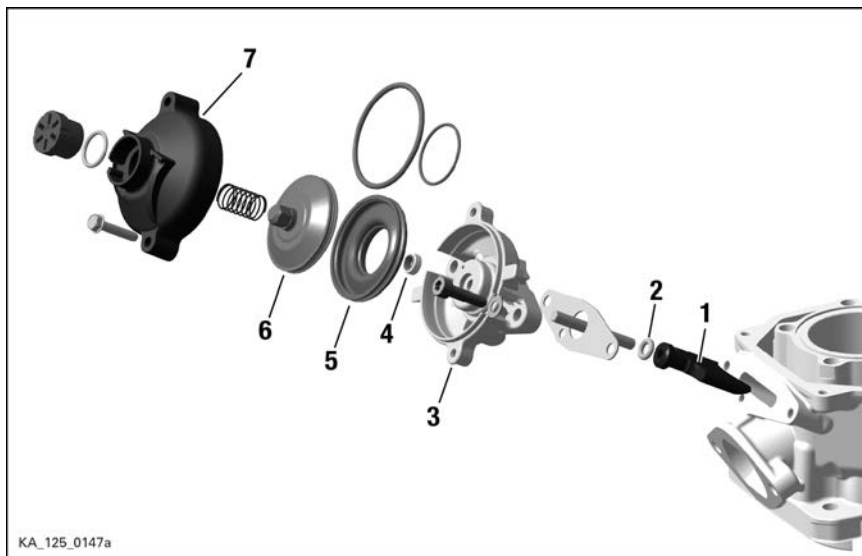

Figure 4.19: Exhaust valve

- | | |
|---------------------------|------------------------|
| 1 Exhaust valve | 2 O-ring 6x2.5 RED |
| 3 Valve rod housing assy. | 4 Oil seal 6x11x3/4.5 |
| 5 Bellow | 6 Exhaust valve piston |
| 7 Valve cover | |

BRP-Rotax
REPAIR MANUAL

CYLINDER COMPONENTS INSTALLATION

INSTALLATION OF EXHAUST VALVE

NOTE

Make sure that the components are in their correct position.

Special tools

The following special tools and equipment are required:

Part no.	Description	Use
899788	LOCTITE 648	Stud
276070	Installation tool	Valve bellows spring

Instruction

See [Figure: Exhaust valve](#).

Proceed as follows to install the exhaust valve:

NOTE

If the exhaust valve or the stud bolt is replaced, the stud bolt must be secured with LOCTITE 648 in the exhaust valve.

1. Lock exhaust valve (1) and stud M6x52.5 (2) with LOCTITE 648.
2. Wipe away the surplus LOCTITE.
3. Make sure the bolt is screwed in completely. Tightening torque 10 Nm (90 in.lb).

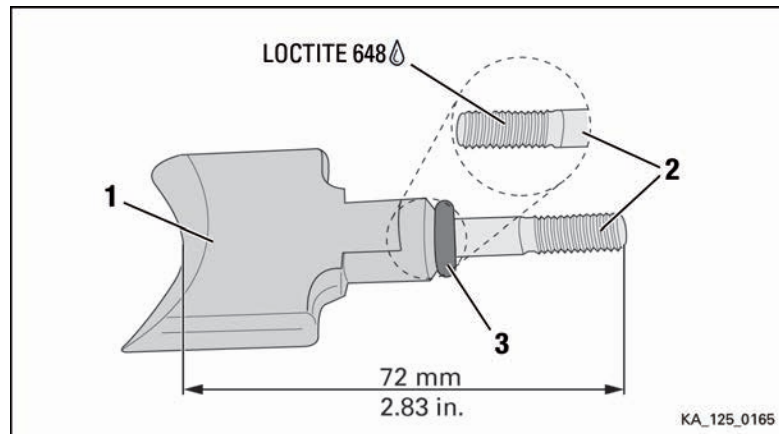

Figure 4.20: Exhaust valve.

- 1 Exhaust valve
- 3 O-ring 6x2.5 RED

2 Stud M6x52.5

BRP-Rotax REPAIR MANUAL

INSTALLATION OF EXHAUST VALVE, GASKET, VALVE ROD HOUSING

Exhaust valve, gasket, valve rod housing See [Figure: Exhaust valve](#).

1. Insert exhaust valve into the slot in the cylinder head (1). Pay attention on the installation direction and make sure that the valve is not ranging into the exhaust port!
2. Position the gasket (4), making sure that the impulse bore on the cylinder is not covered. Note the installation direction!
3. Insert the valve rod housing (5). Coat both side of oil seal (6) with Engine oil and insert into the valve rod housing.
4. Screw in 2 Allen screws M6x25 (7) and spring washers (8) onto the cylinder (1) and tighten.
5. Check the movement of the exhaust valve.
6. Tighten Allen screws (7). Tightening torque 10 Nm (90 in.lb).

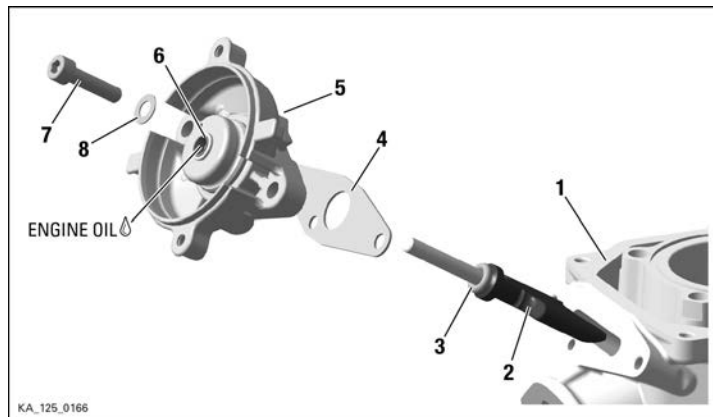

Figure 4.21: Installation direction of exhaust valve

- | | | | |
|---|-------------------------|---|---------------------|
| 1 | Cylinder head | 2 | Exhaust valve |
| 3 | O-ring 6x2.5 RED | 4 | Gasket |
| 5 | Valve rod housing assy. | 6 | Oil seal 6x11x3/4.5 |
| 7 | Allen screw M6x25 | 8 | Spring washers B6 |

INSTALLATION OF THE EXHAUST VALVE PISTON

General In order to protect the piston pin circlip from unintentional loss in the crankcase, a suitable clean cloth should be used to cover the open cylinder bore.

Instruction See [Figure: Exhaust valve piston](#).

1. Degrease the valve rod housing (1), bellows (2) and exhaust valve piston (3).
2. Pull the small hose spring (4) over the bellows.

BRP-Rotax REPAIR MANUAL

3. Fit the bellows over the valve rod housing (1). The bead of the bellows must engage in the groove in the valve rod housing.
4. Tighten the exhaust valve piston (3) into the valve rod housing (1). Tightening torque 1.2 Nm (10.6 in.lb)
5. Tension the large hose spring (5) with installation tool part no. 276070.
6. Insert compression spring (6).
7. Tighten the valve cover (7) with 2 TAPTITE screw M5x25 (8).
8. Insert the O-ring 15.9-2.3 (9) into the valve cover.
9. Turn the adjustment screw (10) into the valve cover (7).

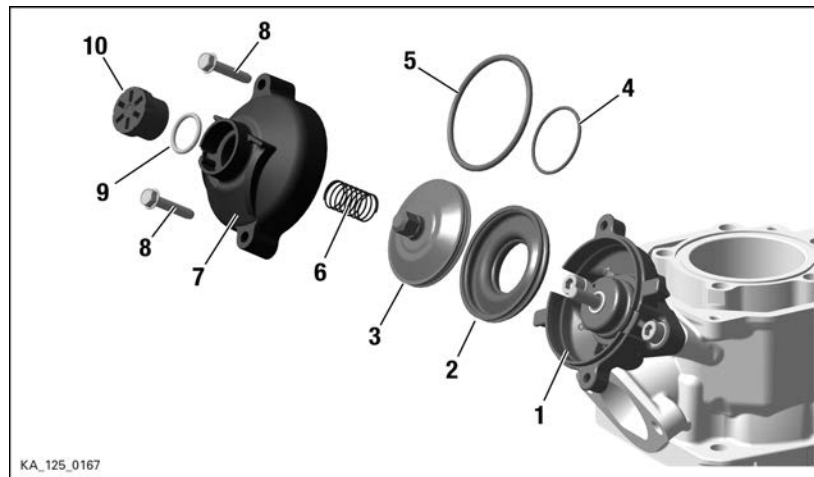

Figure 4.22: Exhaust valve piston

- | | | | |
|---|--------------------------|----|--------------------------------|
| 1 | Valve rod housing assy. | 2 | Bellow |
| 3 | Exhaust valve piston | 4 | Hose spring 70-1.7-0.3 |
| 5 | Hose spring 134-3.0-0.65 | 6 | Compression spring 48.5/0.8 mm |
| 7 | Valve cover | 8 | TAPTITE screw M5x25 |
| 9 | O-ring 15.9-2.3 | 10 | Adjustment screw |

BRP-Rotax REPAIR MANUAL

INSTALLATION OF PISTON

Special tools The following special tools and equipment are required:

Part number	Description	Field of application
676035	Installation tool	Piston
n.a.	Engine oil	Piston pin

NOTE

*Cover your eyes with safety goggles during this work!
Mount the piston with the locking pin of the piston ring facing the intake port.*

NOTE

The piston pin is fixed in the piston with two circlips (left and right).

ATTENTION

Always use new circlips. Used or previously installed circlips have too little tangential tension, and they may twist and work their way out of the groove in the piston.

NOTE

For easier installation we recommend installing one circlip before installing the piston.

Instruction

See [Figure: Piston pin](#).
Proceed as follows to install the piston pin:

1. Coat the piston pin needle cage (2) with Engine oil.
2. Insert the piston pin needle cage (2) into the upper connecting rod eye.
3. Mount the piston (3) and piston pin (4) on the con rod.
4. Place the new circlip (1) flat on a level surface.
5. Push the mounting sleeve (5) with the circlip over it.
6. Push the circlip deeper into the mounting sleeve with the tapered side of the installation tool (6).
7. Rotate the installation tool and continue to push the mounting sleeve until the circlip locks into the mounting sleeve groove.
8. Place the installation tool with the cutout of the circlip down on the piston (3).
9. Protect the piston with your hand and press into the piston with the hook ring.

NOTE

The installation tool centers itself in the piston pin.

BRP-Rotax REPAIR MANUAL

NOTE

Check that the circlip is correctly seated in the piston.

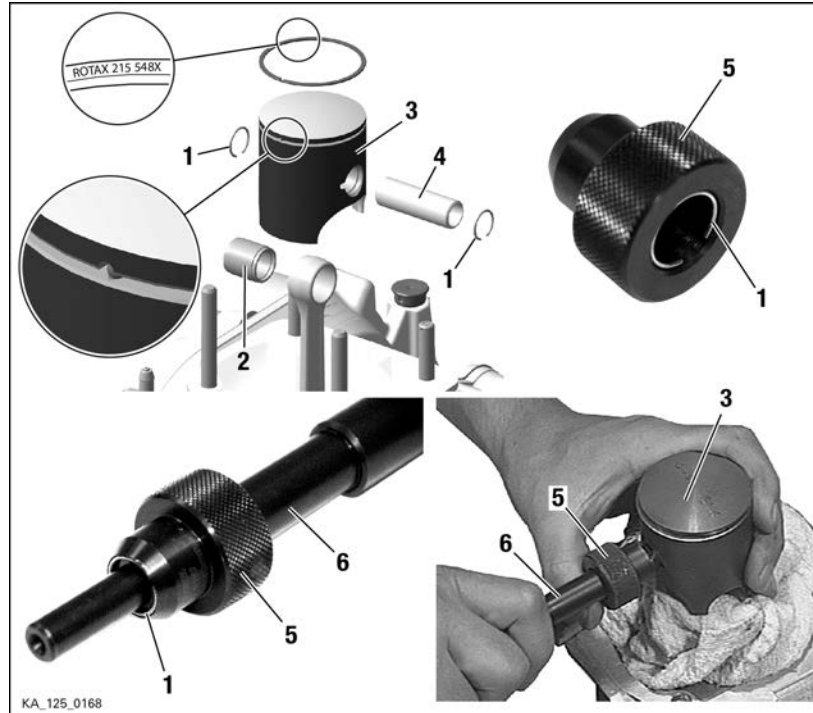

Figure 4.23: Piston pin

- | | |
|-------------------|------------------------------|
| 1 Circlip | 2 Needle cage K 15x19x20 |
| 3 Piston | 4 Piston pin 15x10x12.5x45.6 |
| 5 Mounting sleeve | 6 Installation tool |

INSTALLATION OF THE CYLINDER

General

ATTENTION

Use only the piston/cylinder pairings specified by the table in Chapter 4 Section 3.2. All other combinations may lead to engine damage.

Special tools

The following special tools and equipment are required:

Part no.	Description	Field of application
897651	LOCTITE 243	Stud bolts

BRP-Rotax REPAIR MANUAL

Instructions Proceed as follows to install the cylinder head: See [Figure: Cylinder head](#).

1. Coat the stud bolts (1) on the longer thread end with LOCTITE 243 and screw into the crankcase. Tightening torque 5 Nm (44.25 in.lb).
2. Position new cylinder base gasket (0.2 mm) (4). Determine the correct thickness of the base gasket (see Chapter 4 Section: Squish gap measurement) to adjust the squish gap to the correct value.
3. Coat cylinder bore and piston (2) with Engine oil.
4. Press piston ring into the piston with two fingers.

ATTENTION
Do not damage the gasket.

5. Position the cylinder (3) over the piston.
6. Screw cylinder crosswise to the crankcase with the four studs. Tightening torque 24 Nm (18 ft.lb).

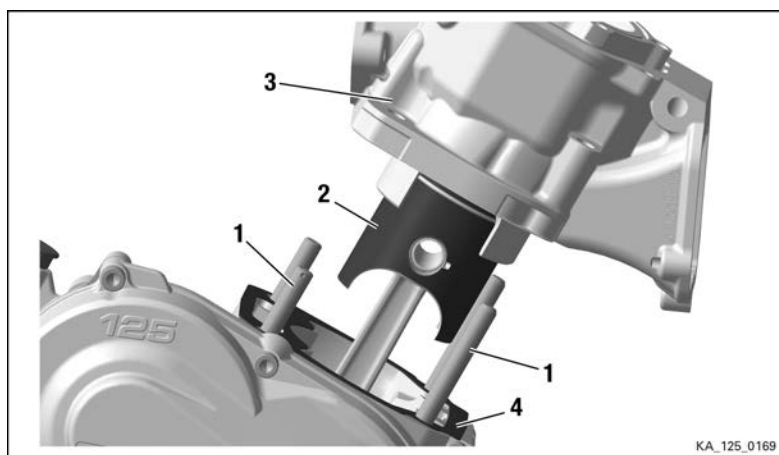

Figure 4.24: Cylinder head

- | | |
|--------------|----------|
| 1 Stud bolts | 2 Piston |
| 3 Cylinder | 4 Gasket |

INSTALLATION OF THE EXHAUST SOCKET

Special tools The following special tools and equipment are required:

Part no.	Description	Field of application
297386	SILASTIC 732	Gasket

Instructions See [Figure: Exhaust socket](#). Proceed as follows to install the exhaust socket:

BRP-Rotax REPAIR MANUAL

1. Coat both sides of the gasket with SILASTIC.
2. Fasten the exhaust socket (1) to the cylinder (5) with a new gasket (4) and 2 Allen screws M8x20 (3). Tightening torque 20 Nm (177 in.lb).
3. Check that the exhaust port is tightly seated on the cylinder.

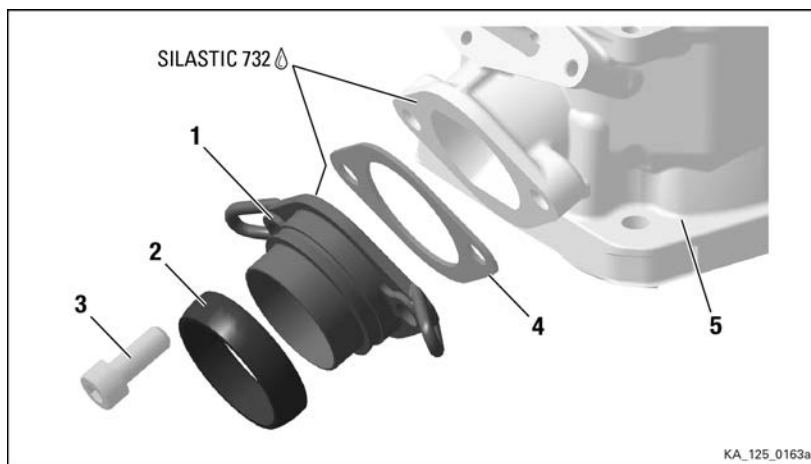

Figure 4.25: Exhaust socket

- | | |
|------------------------|------------------|
| 1 Exhaust socket assy. | 2 Exhaust gasket |
| 3 Allen screws M8x20 | 4 Gasket |
| 5 Cylinder | |

INSTALLATION OF THE CARBURETOR FLANGE AND REED VALVE

Special tools

The following special tools and equipment are required:

Part no.	Description	Field of application
899788	LOCTITE 648	Screw locking

Instructions

See [Figure: Carburetor flange and reed valve](#)
Proceed as follows to install the exhaust socket:

BRP-Rotax REPAIR MANUAL

ATTENTION

The reed petal mounted on the reed valve must be fixed in precisely the correct installation position. Incorrect positioning of this valve leads to disturbed running of the engine due to incomplete combustion.

ATTENTION

The reed petal is bent, not flat. It must be fixed with the concave facing the valve guide. If the valve guide with the correctly fitted reed valve is held up to the light, it must not be possible to see through it.

1. Attach the reed petal (2) and the valve detent (3) to the valve guide using recessed head screws (4). Use LOCTITE 648 to lock the screws.
2. Position the gasket (5) on the cylinder.
3. Position the reed valve (1) and intake socket (6) and fasten together with the support bracket (7) using 5 head screws M6x25 (8)(9). Tightening torque 7 Nm (62 in.lb).

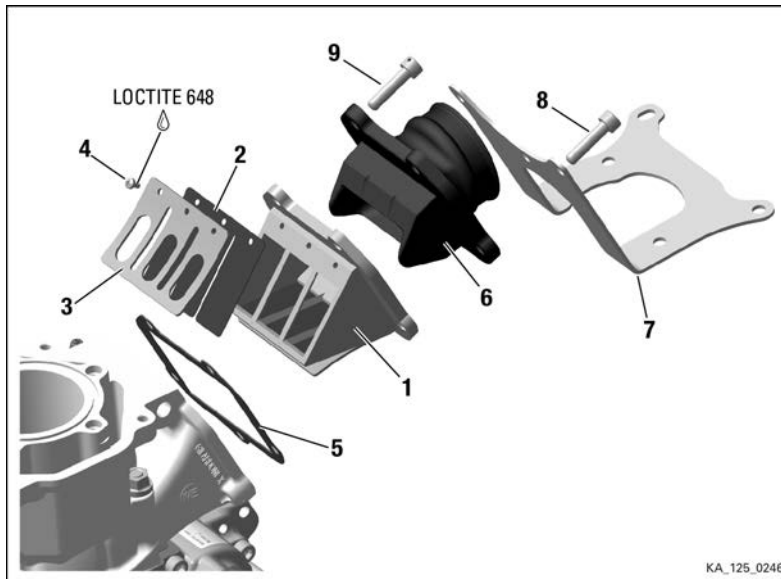

Figure 4.26: Carburetor flange and reed valve

- | | |
|----------------------|---|
| 1 Reed valve | 2 Reed petal |
| 3 Valve detent | 4 Recessed head screw M3x6 |
| 5 Gasket | 6 Carburetor flange |
| 7 Support bracket | 8 Allen screw M6x25, with hole for sealing the engine |
| 9 Allen screw M6x25, | |

BRP-Rotax REPAIR MANUAL

INSTALLATION OF COMBUSTION CHAMBER INSERT

General

NOTE

Note the installation position of the combustion chamber insert (2) - "Made in Austria" points to the exhaust port.

Instructions

See [Figure: Combustion chamber insert](#).

Proceed as follows to install the combustion chamber insert and cylinder head cover:

1. Position O-ring (2) in the groove of the cylinder.
2. Tighten combustion chamber insert (2) crosswise with 5 hex screws (4) and with lock washers (5) to 5 Nm initially, ensuring that the O-ring (3) is not crushed. Tighten to tightening torque 30 Nm (22 ft.lb).

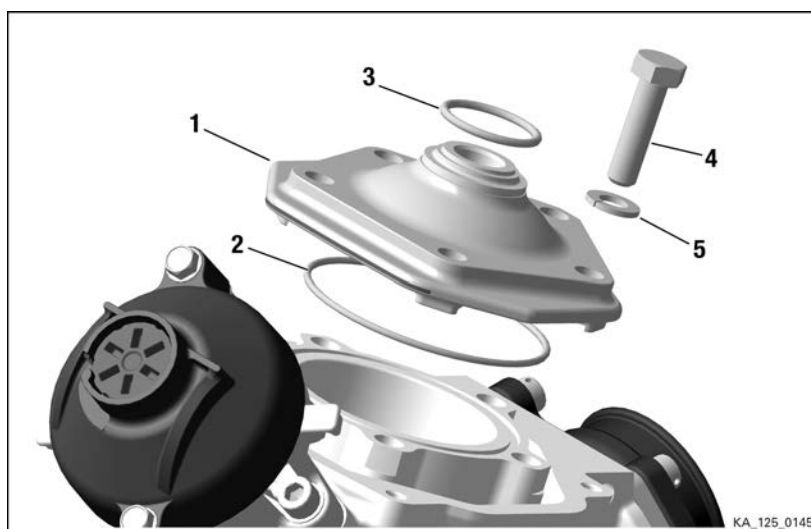

Figure 4.27: Combustion chamber insert

- | | | | |
|---|---------------------------|---|------------------|
| 1 | Combustion chamber insert | 2 | O-ring 64x2 |
| 3 | O-ring 23.3x2.4 | 4 | Hex. screw M8x30 |
| 5 | Lock washer | | |

INSTALLATION OF CYLINDER HEAD COVER

Special tools

The following special tools and equipment are required:

Part no.	Description	Field of application
897651	LOCTITE 243	Screw locking

Preparation

The following preparation is required before installation:

- Installation of the coolant thermostat:

BRP-Rotax REPAIR MANUAL

Instructions

See [Figure: Coolant thermostat](#).

Installation of the coolant thermostat:

1. Install thermostat (2) with collar nut M8 (3), compression spring (4) and thermostat retaining bracket (5) with 2 screws (6). Lock screws with LOCTITE 243.

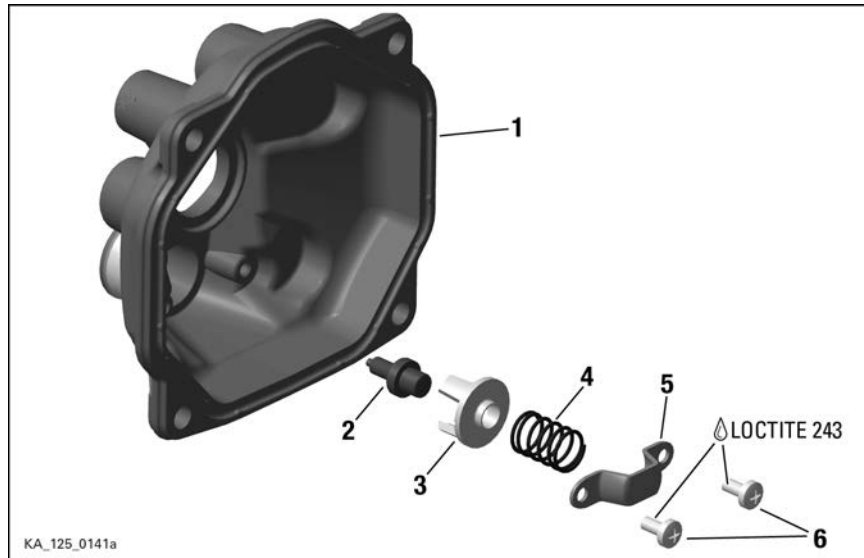

Figure 4.28: Coolant thermostat

- | | | | |
|---|------------------------------|---|------------------------------|
| 1 | Cylinder head cover red | 2 | Thermostat 45 degree celcius |
| 3 | Collar nut M8 | 4 | Compression spring |
| 5 | Thermostat retaining bracket | 6 | TAPTITE screw M4x8 |

Instructions

See [Figure: Combustion chamber insert](#).

Proceed as follows to install the combustion chamber insert:

2. Position O-ring (1) on the combustion chamber insert.
3. Grease the O-ring (2) lightly to ensure that it adheres better to the groove of the cylinder head cover, otherwise fix it with sealant (Silastic).
4. Insert O-ring (2) into the groove of the cylinder head cover (3).
5. Tighten the cylinder head cover (3) crosswise with 4 Allen screws M6x25 (4). Tightening torque 10 Nm (90 in.lb).

BRP-Rotax REPAIR MANUAL

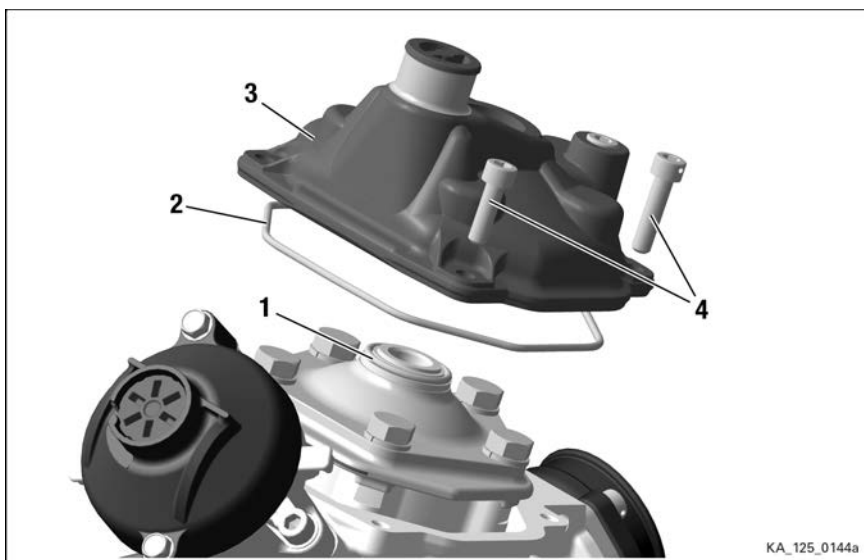

Figure 4.29: Combustion chamber insert

- | | |
|---------------------------|---------------------|
| 1 O-ring 23.3x2.4 | 2 O-ring 64x2 |
| 3 Cylinder head cover red | 4 Allen screw M6x25 |

INSPECTION AND ADJUSTMENT OF SQUISH GAP

General

NOTE

The gap between the piston (at the TDC of the piston) and the combustion chamber insert (= "squish gap") is partly responsible for the power characteristics of the engine and responsible for smooth running.

NOTE

The smaller the squish gap the higher the engine compression. This means that the engine response to the feed from the carburetor becomes more critical under changing operating conditions (temperature, air pressure, humidity).

Special tools

The following special tools and equipment are required:

Part no.	Description	Field of application
580130	Solder 2 mm	Combustion chamber
580132	Solder 3 mm	Combustion chamber
n.a.	Vernier caliper	Solder

Instructions

See [Figure: Crankcase](#).

1. Use a coin to remove plug screw M18x1.5 together with the O-ring.

BRP-Rotax REPAIR MANUAL

2. Screw a M8 bolt into crankshaft and rotate it by hand until the piston is approx. 5 mm below TDC.

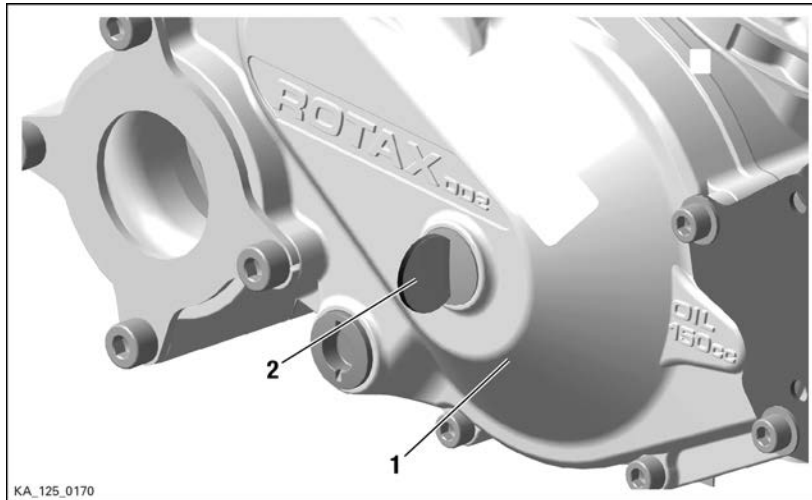

Figure 4.30: Crankcase

1 Crankcase

2 Coin

3. Bend the solder as shown in the following picture and insert through the spark plug thread into the combustion chamber until the solder is in contact with the cylinder bore. The squeeze edge must always be measured in the direction of the axis of the piston pin. The result of a measurement of the squeeze edge in the direction of the exhaust port will be falsified by the tilt of the piston and is not approved.
4. Remove the solder from the combustion chamber and measure the thickness at the very end (= "squish gap") of the crushed end of the solder with a vernier calliper.

BRP-Rotax REPAIR MANUAL

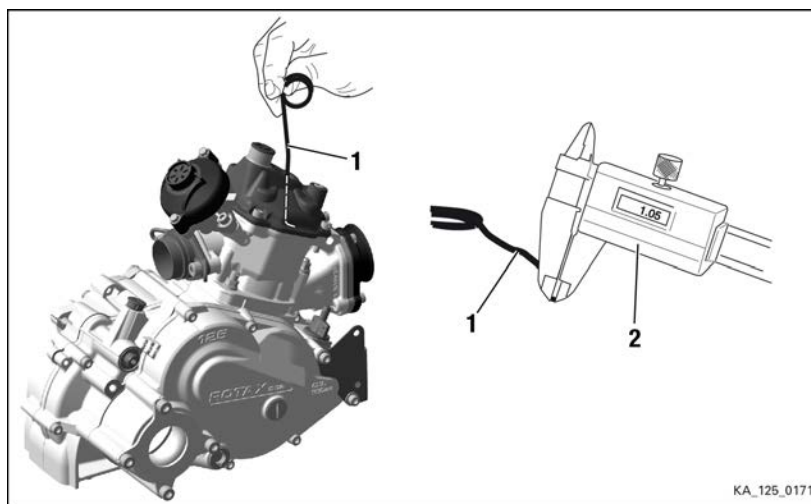

Figure 4.31: Squish gap measurement

1 Solder

2 Vernier caliper

NOTE

A vernier calliper with an accuracy of min. 1/100 mm is required for this measurement.

ATTENTION

The squish gap must be within the specified tolerance.

You find the latest valid reglement on:

www.rotax-kart.com/de/Max-Challenge/MAX-Challenge/Regulations.

NOTE

We recommend setting a squish gap in the upper tolerance range of the relevant model.

NOTE

The squish gap can be set to a different thickness with cylinder base gaskets. Cylinder base gaskets are available 0.2 mm (0.008 in.), 0.3 mm (0.01 in.), 0.4 mm (0.015 in.), 0.5 mm (0.02 in.) and 0.8 mm (0.03 in.) thick.

Example

A cylinder base gasket 0.5 mm (0.02 in.) thick has been installed. With this cylinder base gasket a squish gap of 0.8 mm (0.03 in.) was measured. A cylinder base gasket 0.8 mm thick is required to set the required value, e.g. 1.1 mm (0.043 in.). Of course a 0.5 mm (0.02 in.) and a 0.3 mm (0.01 in.) seal can be installed.

If it is necessary to install a cylinder base gasket with a different thickness, the cylinder can be completely removed by unscrewing the four studs. Follow the directions in the "Installation of the cylinder" chapter for installation of the cylinder. All the components attached to the cylinder (intake socket, exhaust socket) can remain on the cylinder.

BRP-Rotax REPAIR MANUAL

Keep in mind that the gasket will settle and reduce the squish over time.

INSTALLATION OF SPARK PLUG

Instructions Proceed as follows to install the spark plug:

1. Screw in spark plug hand-tight and use tightening torque to tighten it with 27 Nm (20 ft.lb).

BRP-Rotax
REPAIR MANUAL

Chapter: Chapter 5
CRANKCASE

TOPICS IN THIS CHAPTER

System description	2
Removal of the crankcase	5
Disassembling the crankcase.....	6
Installation of the crankshaft repair kit	9
Disassembling of the crankshaft	9
Inspection of the crankshaft.....	13
Crankshaft not in specification	15
Crankshaft - assembly	16
Crank case inspection	20
Inspection of the housing halves	20
Inspection of the gear wheels	21
Crank case - assembly	22
Installation of bearing and oil seal for shaft	22
Installation or Replace sealings	23
Check of the bearings	23
Replace of bearing	24
Installation of shaft and gears	27
Assembly of the gearbox housing	29
Installation of crank case assy.	30

Contents This chapter describes the disassembly and assembly of the crankcase of the ROTAX® 125 MAX DD2 evo engine.

BRP-Rotax
REPAIR MANUAL

SYSTEM DESCRIPTION

Overview

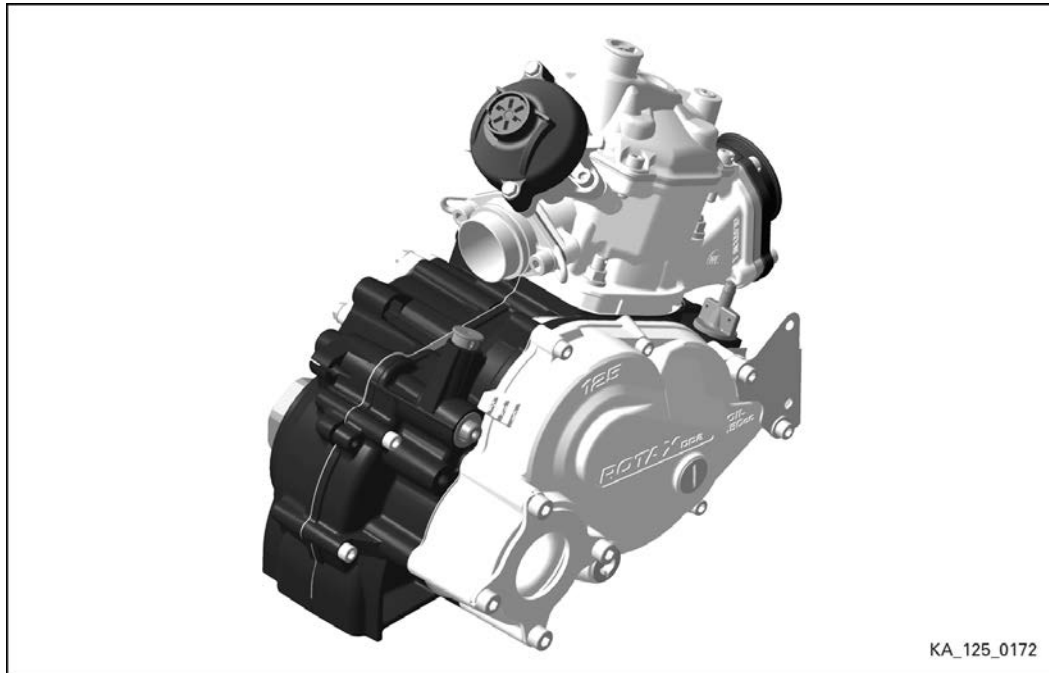

Figure 5.1: Position on the engine

BRP-Rotax REPAIR MANUAL

Overview

Components of crankcase

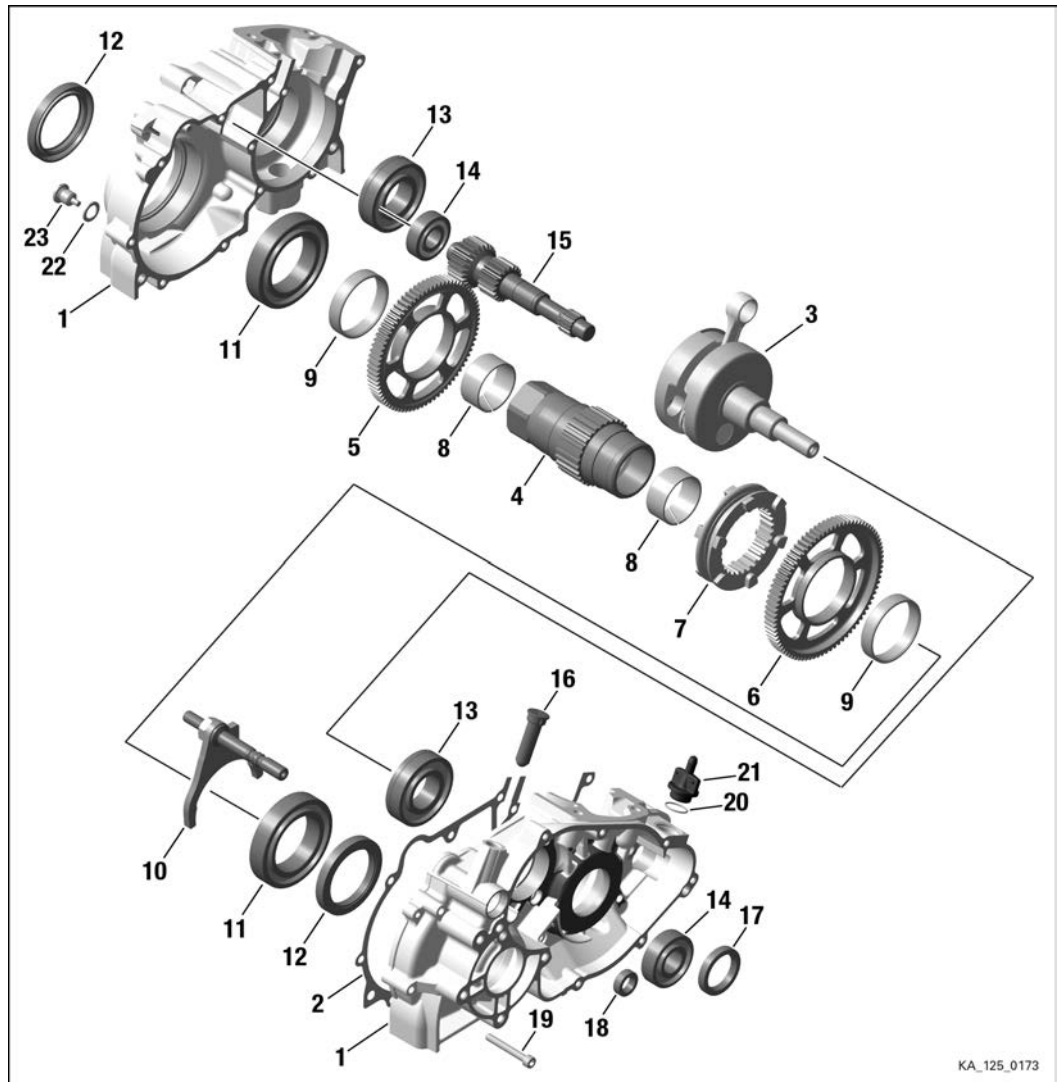

Figure 5.2

- | | |
|-----------------------------|--------------------------|
| 1 Crank case assy. | 2 Gasket |
| 3 Crankshaft assy. | 4 Hollow shaft |
| 5 Idle gear 77 T | 6 Idle gear 81 T |
| 7 Shifting sleeve | 8 Plain bearing 40x44x20 |
| 9 Needle bearing K 52x57x12 | 10 Shift fork assy. |
| 11 Ball bearing 6010 C3 | 12 Oil seal ASL 50x68x8 |
| 13 Ball bearing 6206 | 14 Ball bearing 6204 |

BRP-Rotax REPAIR MANUAL

15	<i>Primary shaft 24/19 T</i>	16	<i>Shift rail detent pin</i>
17	<i>Oil seal AS 30x42x7/7.5</i>	18	<i>Oil seal 12x22x7</i>
19	<i>Allen screw M6x45</i>	20	<i>O-ring 17x1.5</i>
21	<i>Air vent screw M18x1.5</i>	22	<i>Sealing ring A 12x18</i>
23	<i>Magnet drain plug M12x1.5</i>		

REMOVAL OF THE CRANKCASE

Safety information

⚠ WARNING

Danger of severe burns and scalds! Always allow the engine to cool down to ambient temperature before starting any work.

Preparation

The following preparation is required before removal:

1. Removal of ignition system. See also Chapter 3).
2. Removal of the fuel line. See also Chapter 3).
3. Positioning the engine on the trestle mounting plate. See also Chapter 3).
4. Drain oil. See also Chapter 4).
5. Removal of cylinder head. See also Chapter 4).
6. Removal of carburetor. See also Chapter 6).
7. Removal of starter. See also Chapter 7).
8. Removal of radiator. See also Chapter 8).

BRP-Rotax
REPAIR MANUAL

DISASSEMBLING THE CRANKCASE

Special tools

The following special tools and equipment are required:

Part no.	Description	Field of application
276016	Puller assembly	Case halves
n.a.	Plastic hammer	Crankshaft

Instructions

See [Figure: Crankcase](#).

NOTE

Use two hex. screws to separate the case halves

1. Unscrew all Allen screws M6x45 (2) and remove them.
2. Remove engine housing from trestle mounting plate.
3. Screw 3 Cyl. bolts M8x70 into the left side crankcase as a support.

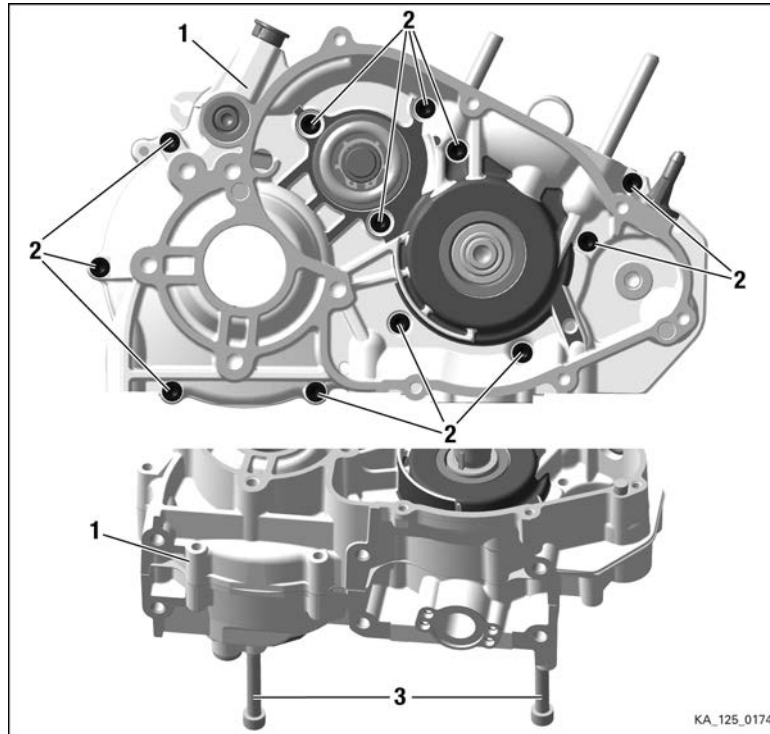

Figure 5.3: Crankcase

1 Crankcase

2 Allen screws M6x45

3 Cyl. screws M8x70

4. Screw 2 jack screws M6x60 (1) evenly into the thread and initiate housing separation.

BRP-Rotax REPAIR MANUAL

5. Separate the housing halves by specific strokes with a plastic hammer.

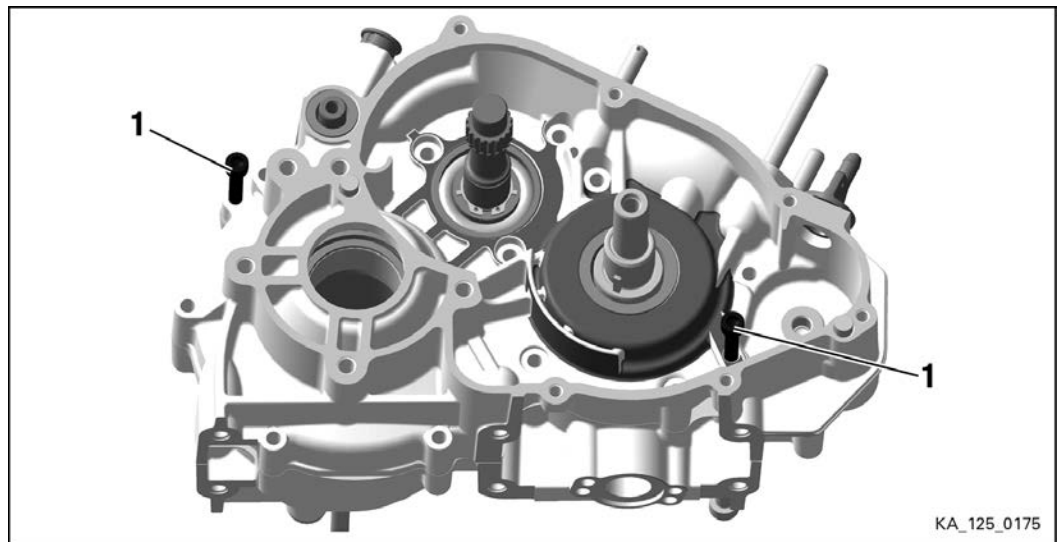

Figure 5.4

1 Allen screw M6x60 (jack screw)

Lay the gearbox housing aside, remove the gasket and the components out of the crankcase in the following order:

6. Remove the idle gear 81 T (2).
7. Pull the shifting sleeve (3) from hollow shaft (5) and the shift fork assy. (4) out of the crankcase.
8. Pull or knock the hollow shaft (5) carefully out of the ball bearings.

NOTE

Do not damage the shaft seal, otherwise it must be renewed!

9. Remove the idle gear (6).
10. Remove needle bearings (7) and plain bearings (8) of the idle gears from the hollow shaft (5).

BRP-Rotax REPAIR MANUAL

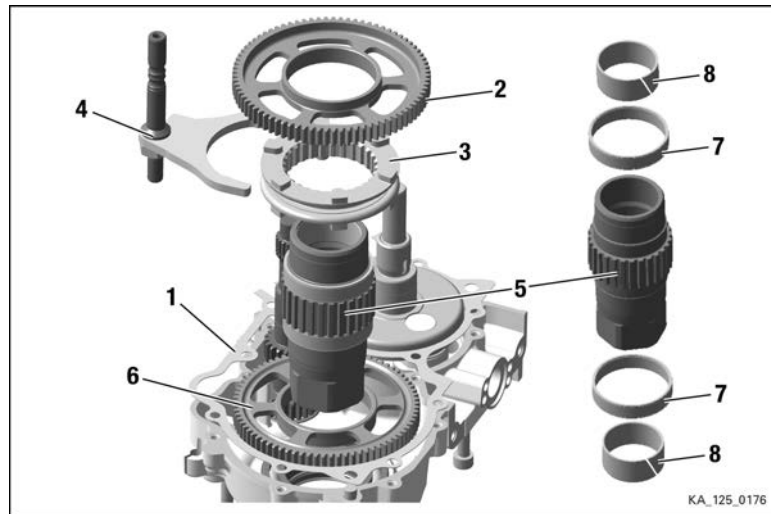

Figure 5.5

- | | |
|-----------------------------|--------------------------|
| 1 Gasket | 2 Idle gear 81 T |
| 3 Shifting sleeve | 4 Shift fork assy. |
| 5 Hollow shaft | 6 Idle gear 77 T |
| 7 Needle bearing K 52x57x12 | 8 Plain bearing 40x44x20 |

11. Pull the crankshaft assy (1) out of the ball bearings.
12. Pull or knock the primary shaft (2) carefully out of the ball bearings.

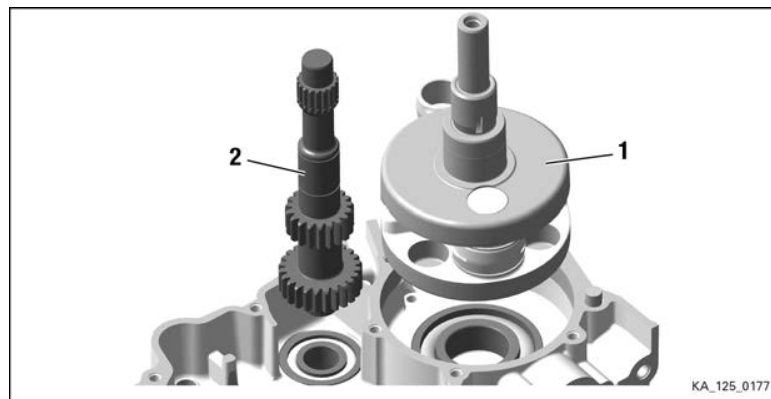

Figure 5.6: Crankcase

- | | |
|--------------------|-------------------------|
| 1 Crankshaft assy. | 2 Primary shaft 24/19 T |
|--------------------|-------------------------|

INSTALLATION OF THE CRANKSHAFT REPAIR KIT

DISASSEMBLING OF THE CRANKSHAFT

Safety instructions

⚠ WARNING

Non-compliance can result in serious injuries or death!

Be particularly careful when working with a tool such as a hydraulic press, and follow the instructions of the manufacturer. All repair and maintenance work must only be carried out by a qualified technician. Generally speaking, we advise to read manuals carefully and follow the instructions.

NOTE

The parts of the crankshaft repair kit are paired together and must therefore be exclusively used together.

NOTE

Before disassembling the crankshaft, clean the parts thoroughly with a cleaning agent (grease-free).

Special tools

The following special tools and equipment are required:

Part no.	Description	Field of application
n.a.	Press	Crankshaft disassembling
n.a.	Dial gauge	Crankshaft measurements
276051	crankshaft repair jig	Crankshaft

BRP-Rotax
REPAIR MANUAL

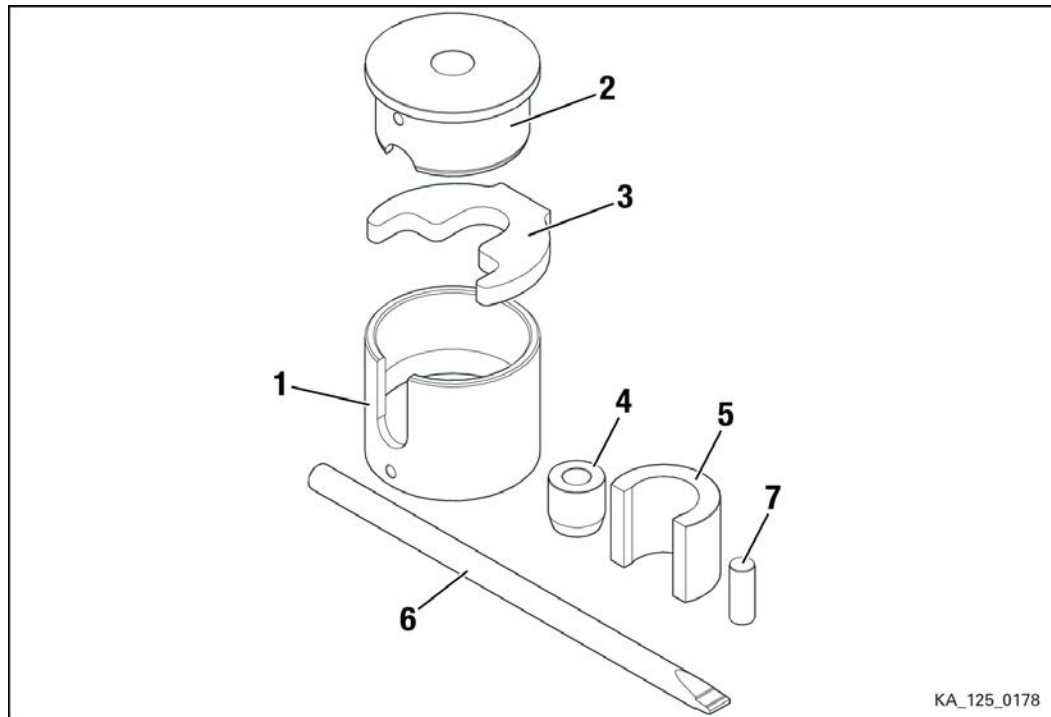

Figure 5.7: Crankshaft repair jig

Part	Part no.	Function
1	276051	Bottom section of the repair jig
2		Top section of the repair jig
3		Thrust plate
4		Sleeve
5		Thrust ring
6		Crowbar
7		Thrust pin/old piston pin

NOTE

*Con rod parts are not part of the crankshaft repair jig (part no. 276051).
The crankshaft repair kit (con rod) is available at your ROTAX® Dealer.*

BRP-Rotax REPAIR MANUAL

Part	Part no.	Description
685011		Crankshaft repair kit (1x)
consisting of:		
1	217431	Con rod (1x)
2	221162	Con rod pin (1x)
3	232884	Needle bearing (1x)
4	227731	Thrust washers (2x)

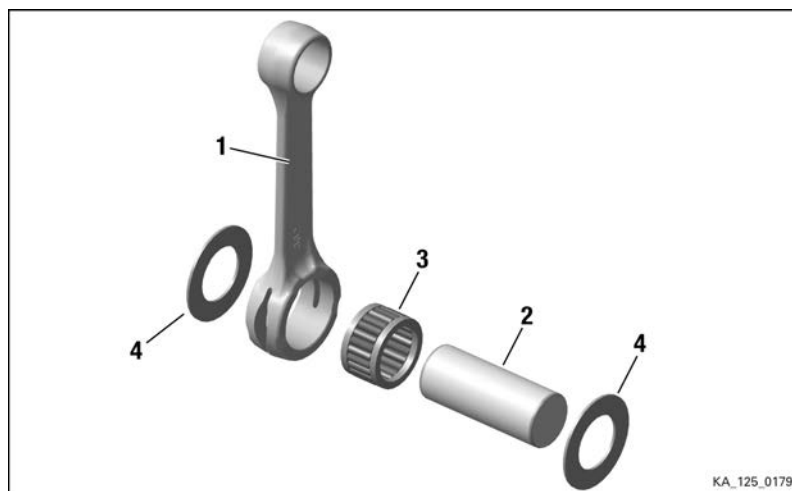

Figure 5.8: Con rod parts

- | | |
|------------------|----------------------|
| 1 Con rod | 2 Con rod pin |
| 3 Needle bearing | 4 Thrust washer (2x) |

Instructions

See [Figure: Disassembling of the crankshaft](#).

NOTE

Position the con rod above the bore of the bottom of the crankshaft repair jig. Otherwise the con rod pin, the crankshaft half or the bottom section may be damaged.

1. Push thrust plate (2) between the two halves of the crankshaft.
2. Position the crankshaft on the thrust plate (3) on bottom section of the tool (4) and make sure that the crankshaft matches the bore in the bottom section at the crankshaft repair jig (4).
3. Position the thrust pin (5) on the connecting rod pin and press the crankshaft apart.

BRP-Rotax REPAIR MANUAL

NOTE

Take an available con rod pin (6) and push the old con rod (7) with needle bearing and thrust washer onto the con rod pin. Note the installation instructions.

4. Take the gearbox-end of the crankshaft half (8) and repeat the procedure.

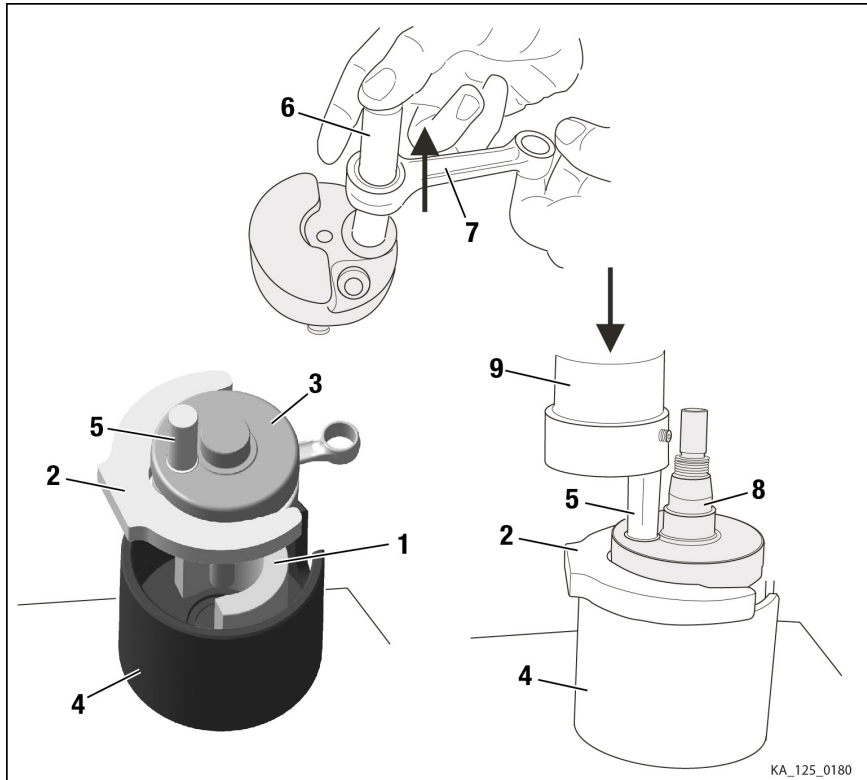

Figure 5.9: TYPICAL – Disassembling of the crankshaft

- | | |
|-------------------|---|
| 1 Thrust ring | 2 Thrust plate |
| 3 Crankshaft half | 4 Bottom section of the crankshaft repair jig |
| 5 Thrust pin | 6 Con rod pin |
| 7 Con rod | 8 Drive side of the crankshaft half |
| 9 Press | |

BRP-Rotax REPAIR MANUAL

INSPECTION OF THE CRANKSHAFT

General

- Thoroughly clean the crankshaft with a grease-free cleaning agent.

Instructions

See [Figure: Crankshaft measurements](#).

1. Inspect the crankshaft for visible damage and traces of wear:
 - Cone/centered thread
 - Bearing seats
 - Running surface of the bearing
 - Contact surface of the shaft seals
 - Woodruff key groove

Measuring the crankshaft

2. Measure values for the two main bearing seats (CS01), the bearing surface of the clutch (CS02) and of the piston pin (CS03).
3. Determine the axial play of the con rod bearing (CS04) using a feeler gauge.
4. Check the specific dimension (CS07).
5. Determine the radial clearance of the connecting rod bearing (CS05).
6. Check the run out of the crankshaft (CS06).

NOTE

If one of the wear limits CS01 or CS02 is reached, the complete crankshaft must be replaced.

NOTE

If one of the wear limits CS03, CS04 or CS05 is reached, BRP-Rotax recommends use of the applicable repair kit. See also Chapter 5 Figure: Con rod parts.

NOTE

If the maximum approved stroke (CS06) of the crankshaft is exceeded, the crankshaft must be realigned. See also Chapter 5 Figure: Crankshaft measurements.

BRP-Rotax
REPAIR MANUAL

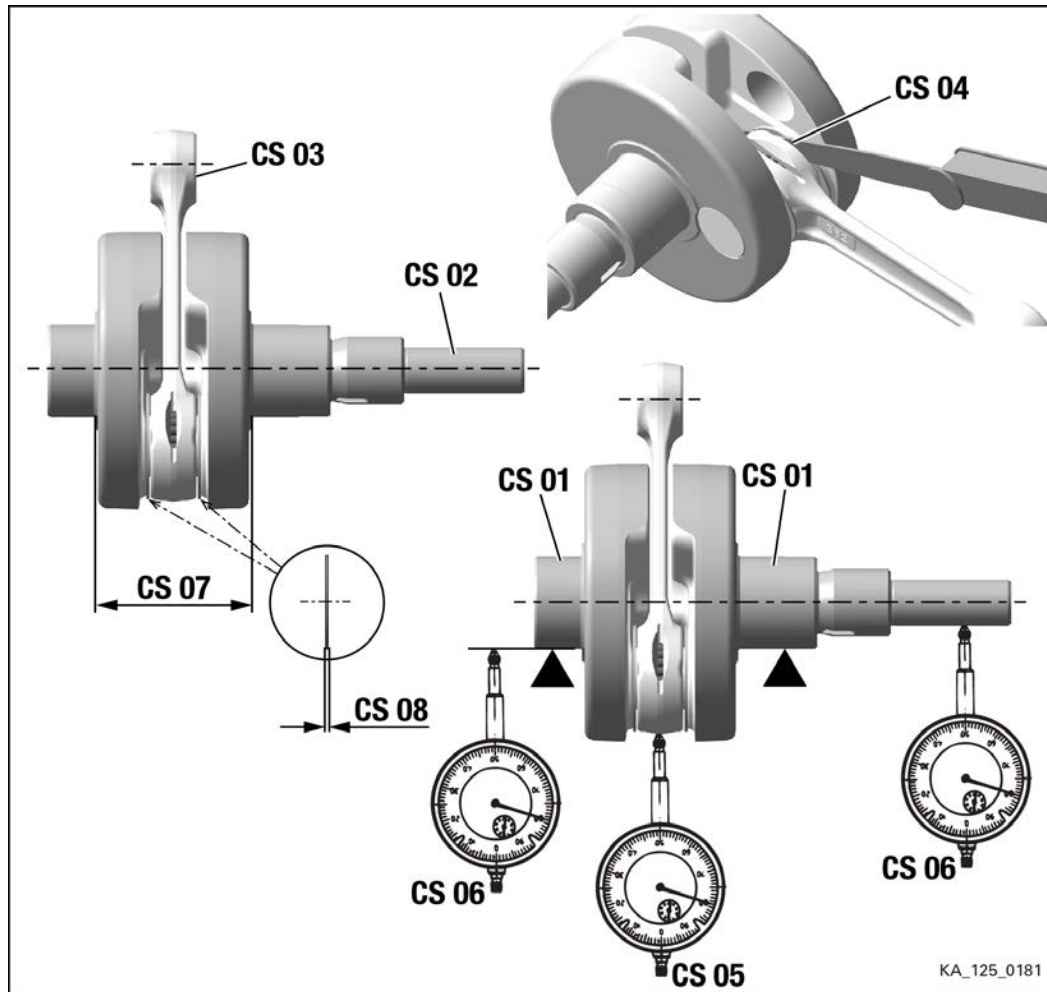

Figure 5.10: Crankshaft measurements

Description	Code	New dimension	Wear limit
Main bearing seat	CS01	29.980 mm - 29.995 mm	29.94 mm
Clutch bearing seat	CS02	14.98 mm - 15.003 mm	14.95 mm
Piston pin bearing seat	CS03	18.99 mm - 19.005 mm	19.015 mm
Conrod bearing axial play	CS04	1.0 mm	1.3 mm
Conrod bearing radial play	CS05	0.05 mm	0.08 mm
Stroke of crankshaft	CS06	0.0 mm - 0.015 mm	0.03 mm

BRP-Rotax REPAIR MANUAL

Description	Code	New dimension	Wear limit
Distance of crank webs	CS07	48.95 mm - 49.05 mm	49.05 mm
Thrust washer thickness	CS08	1.0 mm	0.85 mm

CRANKSHAFT NOT IN SPECIFICATION

General

NOTE

If the crankshaft is not 100% aligned or exceeds the tolerance, the crankshaft must be re-aligned. See CS 07.

Special tools

The following special tools and equipment are required:

Part no.	Description	Field of application
276051	Crankshaft repair jig	Crankshaft
n.a.	Vise	

Instructions

See [Figure: Aligning the crankshaft](#).

- To align the crankshaft, clamp the drive end or engine end of the crankshaft half (1) in a vise (2). Use a soft material to cover the crankshaft inside the vise to protect the surface.
- Use the lever (3) to lift up the upper half of the crankshaft.

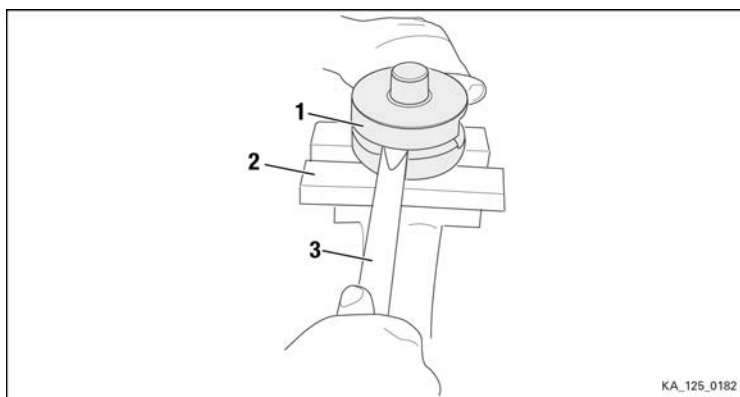

Figure 5.11: Aligning the crankshaft

1 Crankshaft half
3 Crowbar

2 Vise

- The crankshaft can be aligned to the external diameter of the crankshaft webs with target strokes of an aluminum hammer.

BRP-Rotax REPAIR MANUAL

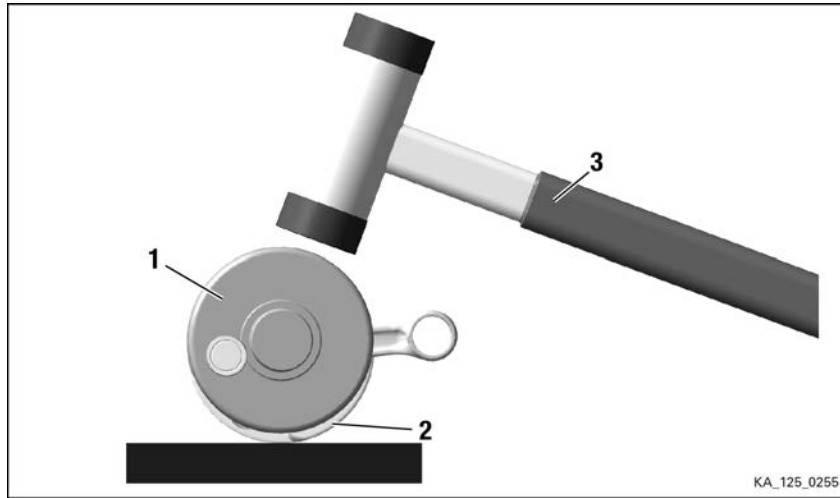

Figure 5.12: Aluminum hammer

- 1 Crankshaft half
- 2 Crankshaft
- 3 Aluminum hammer

CRANKSHAFT - ASSEMBLY

General

NOTE

Clean the bore for the connecting rod pins of the gearbox-side crankshaft half with a cleaning agent (grease-free).

Special tools

The following special tools and equipment are required:

Part no.	Description	Field of application
n.a.	Press	Crankshaft
276051	Crankshaft repair jig	Crankshaft
899788	LOCTITE 648	Crank pin

Instructions

See [Figure: Crankshaft assembly](#).

1. Apply LOCTITE 648 to the inside of the crank pin bore in both crankshaft halves.

NOTE

Remove excess LOCTITE after pressing in, otherwise adjacent parts may be damaged.

2. Insert the new con rod pin (5) into the crankshaft bore.
3. Place the sleeve (6) over it.

BRP-Rotax REPAIR MANUAL

NOTE

Transfer the new con rod from the old con rod pin to the pressed-in (new) con rod pin in the crankshaft repair jig. (note the installation position).

4. Position the drive end crankshaft half (3) on the thrust plate (2) and press the new con rod pin (5) into the crankshaft until the con rod pin stops moving, then remove the sleeve (6).
- 5.

NOTE

Before positioning the con rod on the pressed-in con rod pin check for:

- no corrosion damage
- no dirt or dust particles
- check that all bearing needles are present

Slide the new crankshaft assy. (7) with cage from the con rod pin (mounting device) onto the pressed-in con rod pin (5).

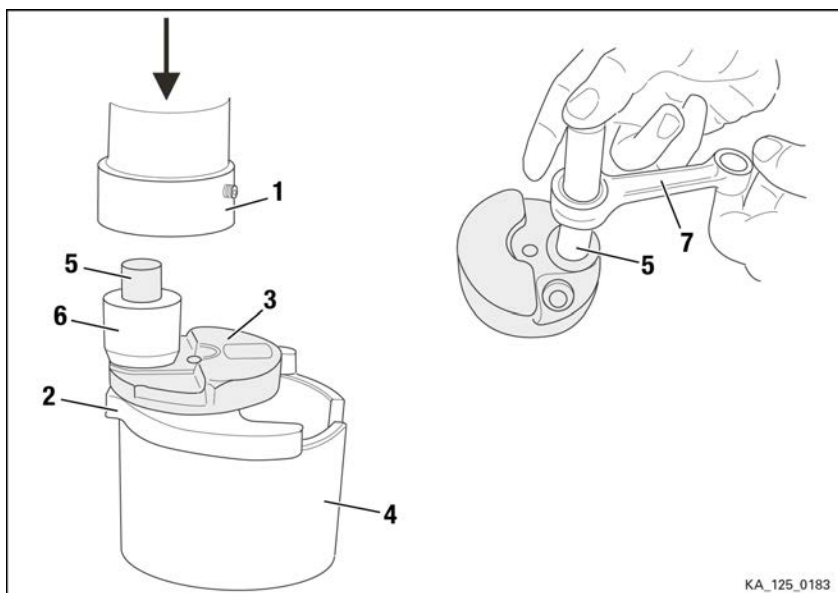

Figure 5.13: Crankshaft assembly

- | | |
|-----------------------------|------------------------------------|
| 1 Press | 2 Thrust plate |
| 3 Drive end crankshaft half | 4 Bottom section of the repair jig |
| 5 Con rod pin | 6 Sleeve |
| 7 Crankshaft | |

Instructions See [Figure: Crankshaft assembly](#).

6. Slide the gearbox-end crankshaft half (1) into the bottom section of the tool (2).

BRP-Rotax REPAIR MANUAL

7. Clean the drive end crankshaft web hole with cleaning agent (grease-free).
8. Coat the hole with LOCTITE 648.

NOTE

Remove excess LOCTITE, otherwise the con rod may be damaged.

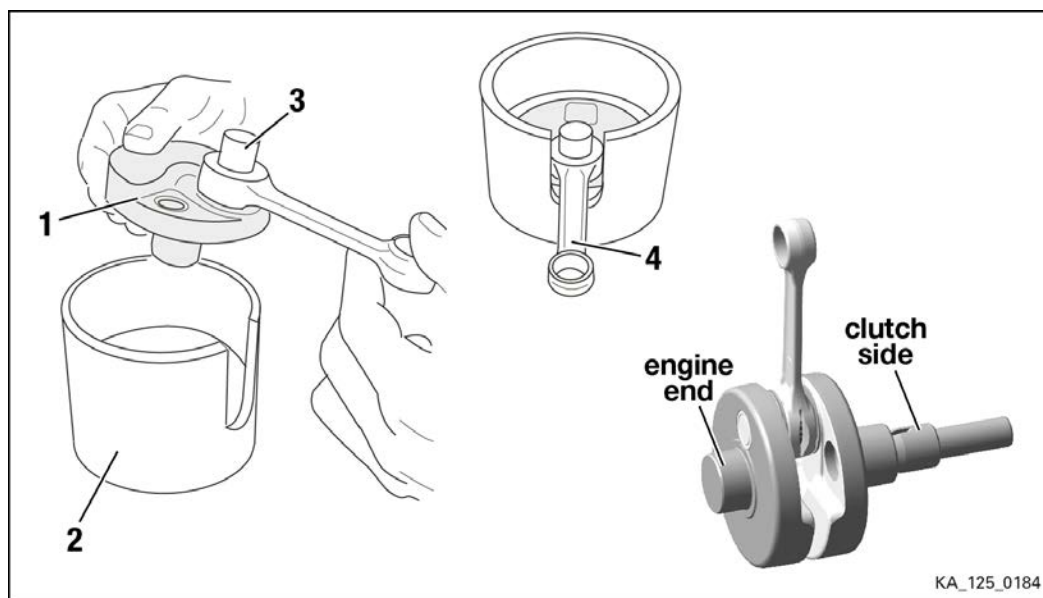

Figure 5.14: Crankshaft assembly

- | | |
|--------------------------------|------------------------------------|
| 1 Crankshaft half (engine end) | 2 Bottom section of the repair jig |
| 3 Con rod pin | 4 Con rod |

9. Slide the drive-end crankshaft half (1) into the top section of the repair jig (2).
10. Hold the crankshaft half as shown in following Figure and push the top section of the tool (3) into the bottom section of the tool (2).

NOTE

A rotary movement of the con rod makes it easy to align the web hole with the con rod pin.

11. Position the thrust ring (4) on the top section of the repair jig and press the two crankshaft halves together (until the crankshaft pin is aligned with the crankshaft web).

BRP-Rotax REPAIR MANUAL

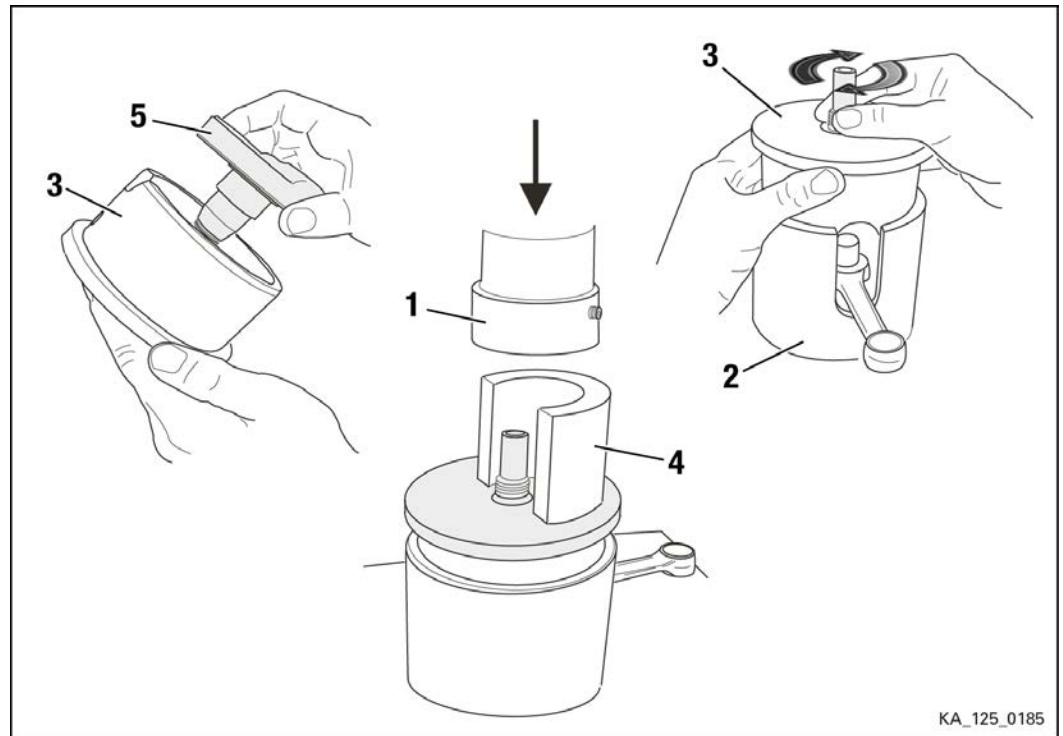

Figure 5.15: Crankshaft assembly

- | | |
|---------------------------------|------------------------------------|
| 1 Press stamp | 2 Bottom section of the repair jig |
| 3 Top section of the repair jig | 4 Thrust ring |
-

CRANK CASE INSPECTION

INSPECTION OF THE HOUSING HALVES

Instructions See [Figure: Crankcase](#).

1. Clean both case halves with commercial detergents.
2. Check both halves (1) for cracks and damage (visual inspection).
3. Check sealing surfaces (2) for damage (visual inspection).
4. Check threads (3) for cleanliness and clearance.
5. Check that lubrication holes (4) are open and clean with compressed air as required.

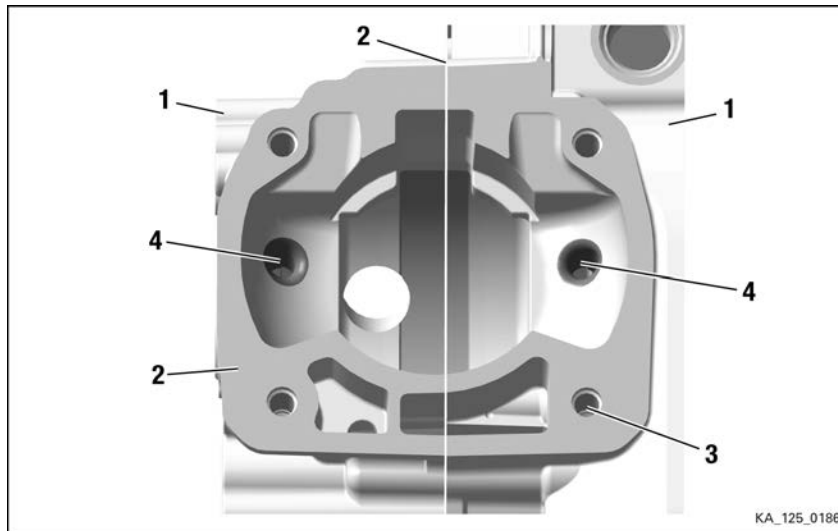

Figure 5.16: Crankcase

1 Case halves

2 Sealing surfaces

3 Thread

4 Main bearing lubrication hole

BRP-Rotax REPAIR MANUAL

INSPECTION OF THE GEAR WHEELS

Instruction See [Figure: Gear wheels](#).

1. Check the following gearbox components in the context of a revision of the engine for corrosion, damage or wear:
 - Gear wheels of primary shaft 24/19 T
 - Idle gear 81 T
 - Shifting sleeve and shift fork assy.
 - Plain bearing 40x44x20
 - Hollow shaft
2. Check for discoloration of components, in addition inspect the gearing for pitting. Blue color means that this part was subjected to massive heat and should be replaced.

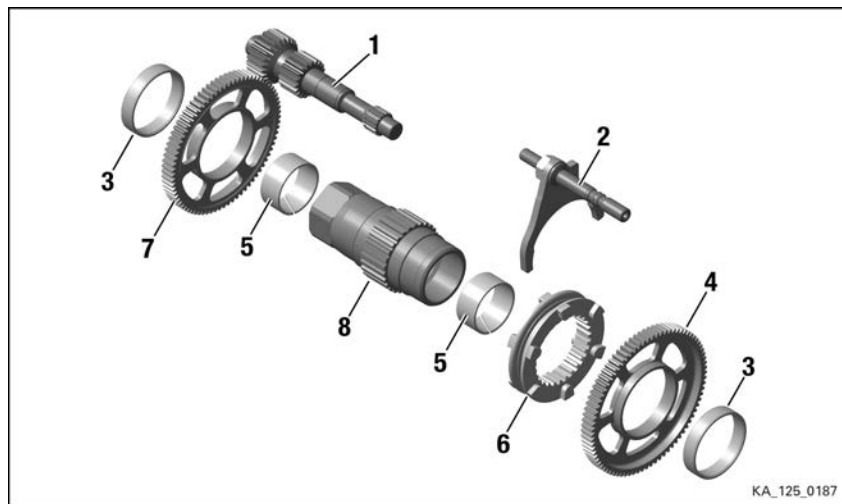

Figure 5.17: Gear wheels

- | | | | |
|---|---------------------------|---|------------------|
| 1 | Primary shaft 24/19 T | 2 | Shift fork assy. |
| 3 | Needle bearing K 52x57x12 | 4 | Idle gear 81 T |
| 5 | Plain bearing 40x44x20 | 6 | Shifting sleeve |
| 7 | Idle gear 77 T | 8 | Hollow shaft |

BRP-Rotax
REPAIR MANUAL

CRANK CASE - ASSEMBLY

General

NOTE

Always replace old gaskets, circlips, O-rings and oil seals with new ones after disassembling.

Special tools

The following special tools and equipment are required:

Part no.	Description	Use
n.a.	Convection oven or heating plate	Case halves
676030	Installation tool	Needle bearing
676010	Mounting sleeve	Shaft seal
676021	Installation tool	
n.a.	2-stroke engine oil	Shaft seal
n.a.	MOLYCOTE 111	Shaft seal

INSTALLATION OF BEARING AND OIL SEAL FOR SHAFT

⚠ WARNING

Danger of severe burns and scalds! Always allow the engine to cool down to ambient temperature before starting any work.

Special tools

The following special tools and equipment are required:

Part no.	Description	Field of application
n.a.	Convection oven e.g. heater plate (if required)	Crankshaft
676030	Installation tool	Needle bearing
676021	Installation tool	Shaft seal, water pump

BRP-Rotax REPAIR MANUAL

INSTALLATION OR REPLACE SEALINGS

General

Replace sealing rings if:

- they are damaged or leaking
- directly adjacent bearings must be renewed pairwise
- as part of an overhaul – Does not always have to be replaced.

Instruction

See [Figure: Display of oil seals](#).

1. Pull out the sealings from the bearing seats of the crankshaft, hollow shaft and shift fork/sleeve with a suitable tool.
2. Grease the new oil seal with Molykote 111 in the area of the sealing lip and install it with a suitable installation tool.

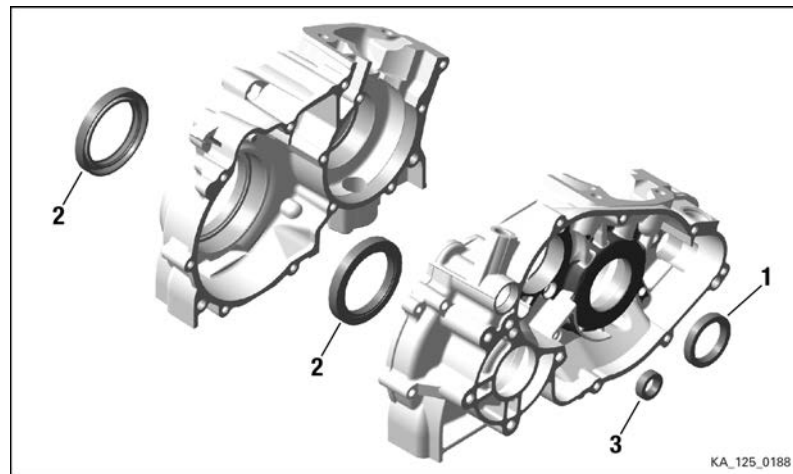

Figure 5.18: Display of oil seals

1 Oil seal AS 30x42x7/7.5

2 Oil seal ASL 50x68x8

3 Oil seal 12x22x7

CHECK OF THE BEARINGS

NOTE

*Before the inspection, lubricate the bearings with engine oil.
If the bearing on one side is damaged, always replace the adjacent bearings too.
Always replace the according oil seal when replacing a bearing!*

NOTE

If one of the bearings has to be replaced, then replace the shaft seal also.

Instruction

See [Figure: Check of bearing](#).

BRP-Rotax REPAIR MANUAL

1. Turn the inner ring of the bearing (by hand), it must be easy and free to turn. The bearing must not be “noisy”. If in doubt, replace the bearing to prevent any damage.

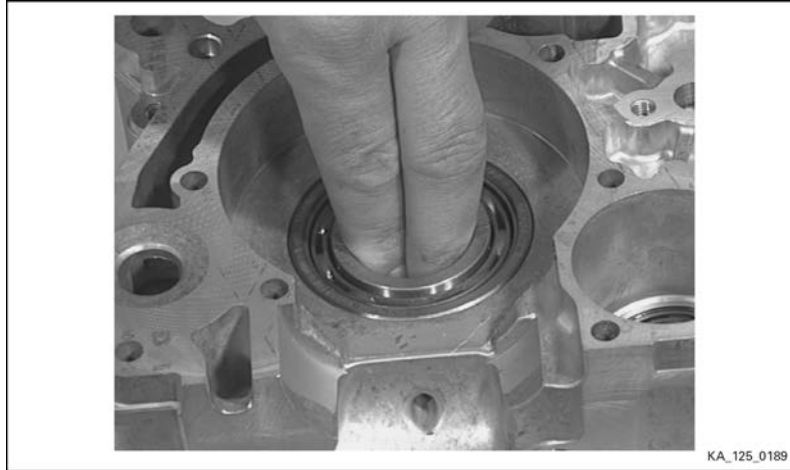

Figure 5.19: Check of bearing

REPLACE OF BEARING

⚠ WARNING

Danger of severe burns and scalds!
Wear heat-resistant gloves during this process!

ATTENTION

Check for wear at the bearing support. If the press fit of the bearing in relation to the crank case is loose, replace the crank case half that is affected.

NOTE

Remove the components of the housing in order to avoid damage during the heating process.

NOTE

If the housing half that needs to be heated has dowel pins, drill corresponding holes into the wood or plastic plate to accommodate the pins after heating.

Instruction See [Figure: Ball bearing](#).

1. Heat up the housing halves with the defective ball bearings one after the other for 10 minutes at 150 °C (302 °F).

BRP-Rotax REPAIR MANUAL

2. Take one housing half out of the oven in correct position and swing it lightly onto a flat surface, preferably of wood, then the defective ball bearing will pop out of the crank case by using only little force.
3. Clean the bearing seats carefully.

NOTE

Components must have cooled to room temperature (20 °C) (68 °F). Otherwise a measurement is not valid!

4. Measure the inner diameter of the bearing seat and the outer diameter of the bearing. The interference fit between the ball bearing and the bearing seat must be at least $s = 0.01$ mm.
5. Heat up the halves again to 150 °C (302 °F) for 10 minutes.
6. Lay a crank case half on a flat surface, lubricate bearing area with lithium-based grease.
7. Lubricate the ball bearings with engine oil and insert them into the bearing seats carefully. Do not tilt the bearing, otherwise you have to start again!

NOTE

Crankshaft main bearing: The closed cage side must face the crank web!
See [Figure: Crankshaft main bearing](#) (next side). The bearing description must be visible!

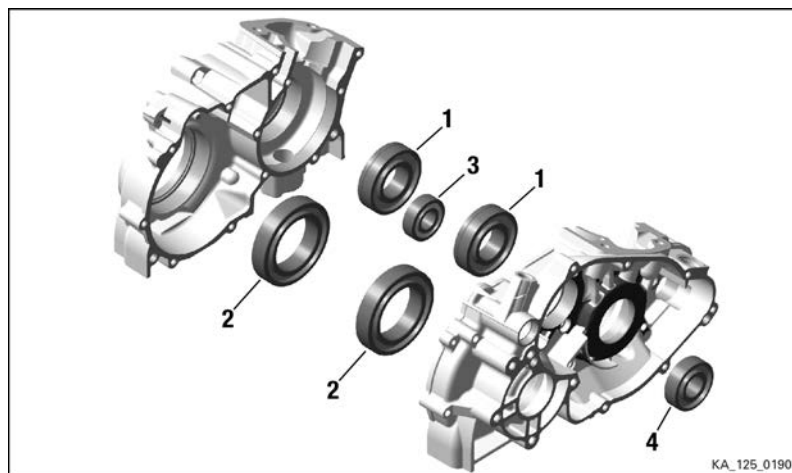

Figure 5.20: Ball bearing

- | | | | |
|---|--|---|--------------------------------------|
| 1 | Ball bearing (crankshaft) 6206 TVH C4M | 2 | Ball bearing (hollow shaft) 6010 C3 |
| 3 | Ball bearing (primary shaft) 6203 C3 | 4 | Ball bearing (primary shaft) 6204 C3 |

BRP-Rotax REPAIR MANUAL

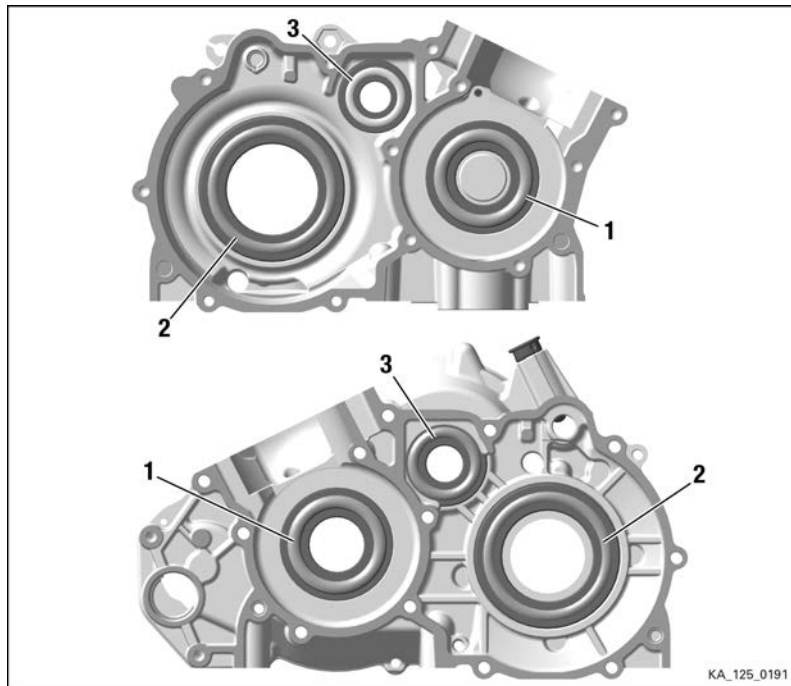

Figure 5.21: Crankshaft main bearing

- 1 *Ball bearing (crankshaft) 6206 TVH C4M*
 - 2 *Ball bearing (hollow shaft) 6010 C3*
 - 3 *Ball bearing (primary shaft) 6204 C3*
-

BRP-Rotax REPAIR MANUAL

INSTALLATION OF SHAFT AND GEARS

Preparation

See [Figure: Crank case housing](#).

Put the crank case housing (ignition side) on the work bench!

1. Screw three Allen screw M8x70 evenly into the extraction thread and use them as pedestal.

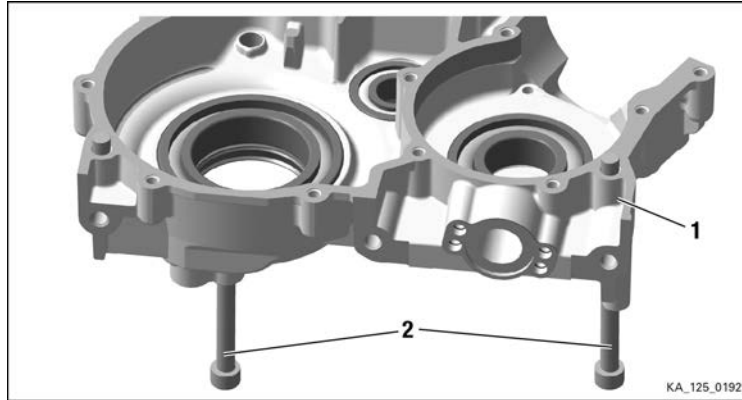

Figure 5.22: Crankcase housing

1 Crank case housing

2 Allen screws M8x70

Instruction

See [Figure: Crankshaft assy., Primary shaft](#).

2. Insert the crankshaft (1) into the ball bearing of the gearbox housing (case).
3. Insert the primary shaft (2) carefully into the ball bearing of the gearbox housing (case).

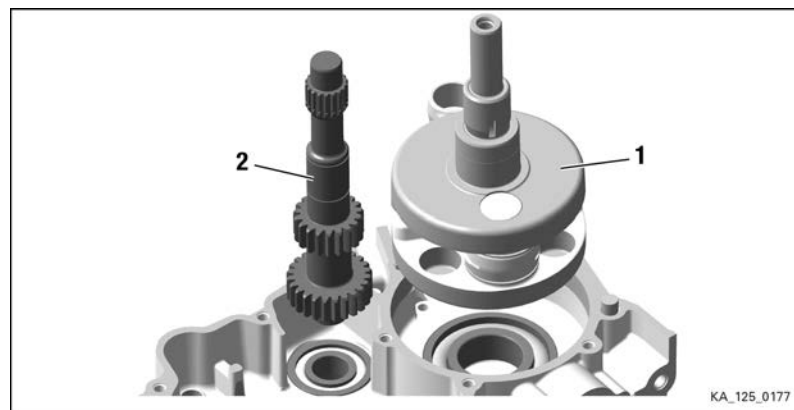

Figure 5.23: Crankshaft assy, Primary shaft

1 crankshaft assy.

2 Primary shaft

Instruction

See [Figure: Shafts and wheels](#).

BRP-Rotax REPAIR MANUAL

Proceed as follows to installation the shafts and gears.

4. Assemble the hollow shaft with bearing sleeves, needle bearings, shifting sleeve, shift fork, idle gears and install it into the gearbox housing.
 - First install the hollow shaft (1) with the hexagonal end into the ball bearing of the gearbox housing - Avoid possible damage to the oil seal (7).
 - Pay attention to order and direction when installing the idle gears: First install the idle gear (5) (2.gear) onto the hollow shaft, then install the idle gear (9) (1.gear). Both idle gears indicate with the flat side to the shifting sleeve (4)!
5. Assemble the housing halves. Described in section Assembly of housing valves.

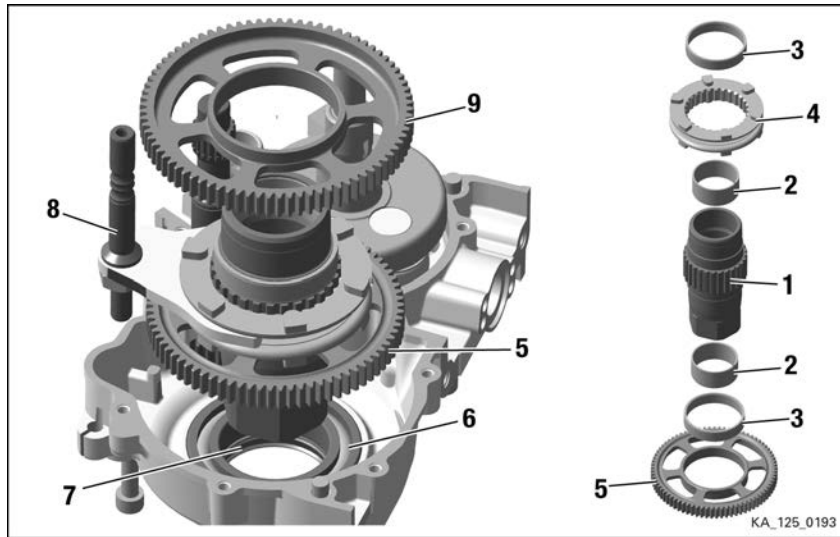

Figure 5.24: Shafts and wheels

- | | | | |
|---|---------------------------|---|------------------------|
| 1 | Hollow shaft | 2 | Plain bearing 40x44x20 |
| 3 | Needle bearing K 52x57x12 | 4 | Shifting sleeve |
| 5 | Idle gear 77 T | 6 | Ball bearing 6010 C3 |
| 7 | Oil seal ASL 50x68x8 | 8 | Shift fork assy. |
| 9 | Idle gear 81 T | | |

BRP-Rotax REPAIR MANUAL

ASSEMBLY OF THE GEARBOX HOUSING

General

NOTE

*When using new studs for the assembly of the cylinder, first screw the long side of the threaded studs into the housing and secure them with LOCTITE 243.
Tightening torque 10 Nm.*

When using new housing halves insert new dowel pins!

Instruction

ATTENTION

Pay attention on the different lengths of the Allen. screws!
Tighten the Allen. screws crosswise, start in the middle of the housing.

1. Insert a new housing gasket part no. 630522 included in the gasket set part no. 296162.
2. Mount both housing halves together with 12 Allen screws M6x45 (see mounting plan) together.
Tightening torque 10 Nm.
3. Crankcase assy. –cool down.
4. Attach the crankcase assy. on trestle mounting plate with 4 attachment screws.

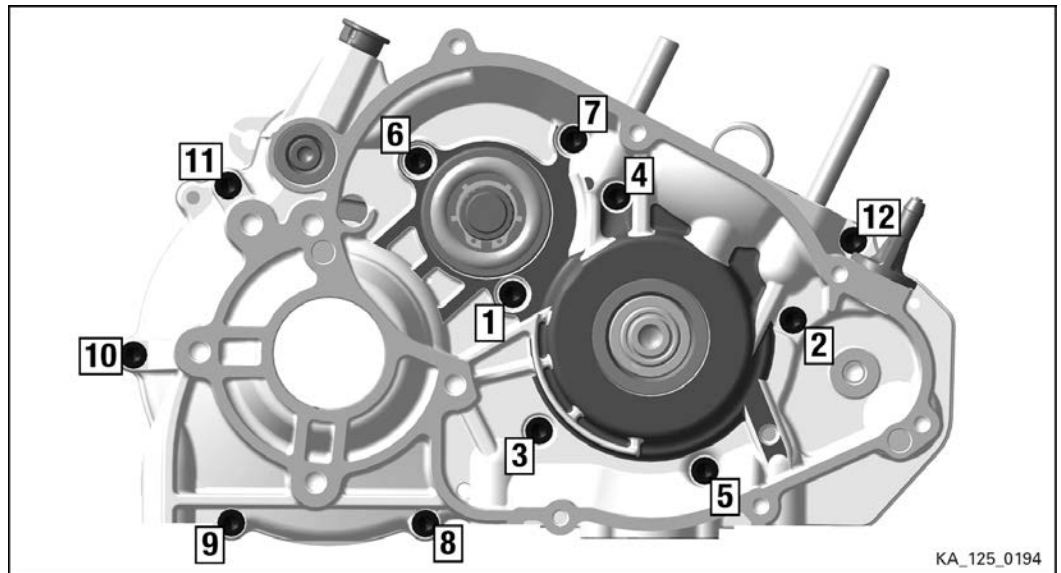

Figure 5.25: Mounting plan 1-12

BRP-Rotax **REPAIR MANUAL**

5. Cut off the protruding section of the crankcase gasket with a sharp knife at the cylinder base surface.

INSTALLATION OF CRANK CASE ASSY.

Final tasks

1. Install cylinder assy. See Chapter 4).
2. Install balance drive and centrifugal clutch. See Chapter 7).
3. Take the engine off the assembly stand. See Chapter 3).
4. Install the engine in the kart chassis. See Chapter 3).
5. Filling the gear housing with oil. See Chapter 7).
6. Install the fuel line. See Chapter 3).
7. Install the exhaust system. See Chapter 9).
8. Install the carburetor and air filter. See Chapter 6).
9. Install the water pump hoses. See Chapter 8).
10. Install the ignition system. See Chapter 3).

Chapter: Chapter 6
CARBURETOR AND INTAKE SILENCER

TOPICS IN THIS CHAPTER

System description	2
Removal of the carburetor and intake silencer	3
Removal of the carburetor, intake silencer	3
Removal of the fuel pump.....	5
Disassembly of the carburetor	5
Disassembly of the intake silencer	7
Carburetor and intake silencer – inspection of components	8
Inspection of the carburetor	8
Inspection of the fuel pump	9
Inspection of the intake silencer.....	9
Installing the carburetor and intake silencer.....	11
Assembly of carburetor	11
Assembly of float housing	11
Assembly of intake silencer	12
Installation of fuel pump, carburetor	13

Contents This chapter describes the removal and installation of the carburetor and intake silencer assembly for the ROTAX® 125 MAX DD2 evo engine. The description is divided into subsections.

BRP-Rotax
REPAIR MANUAL

SYSTEM DESCRIPTION

Overview

Position on engine

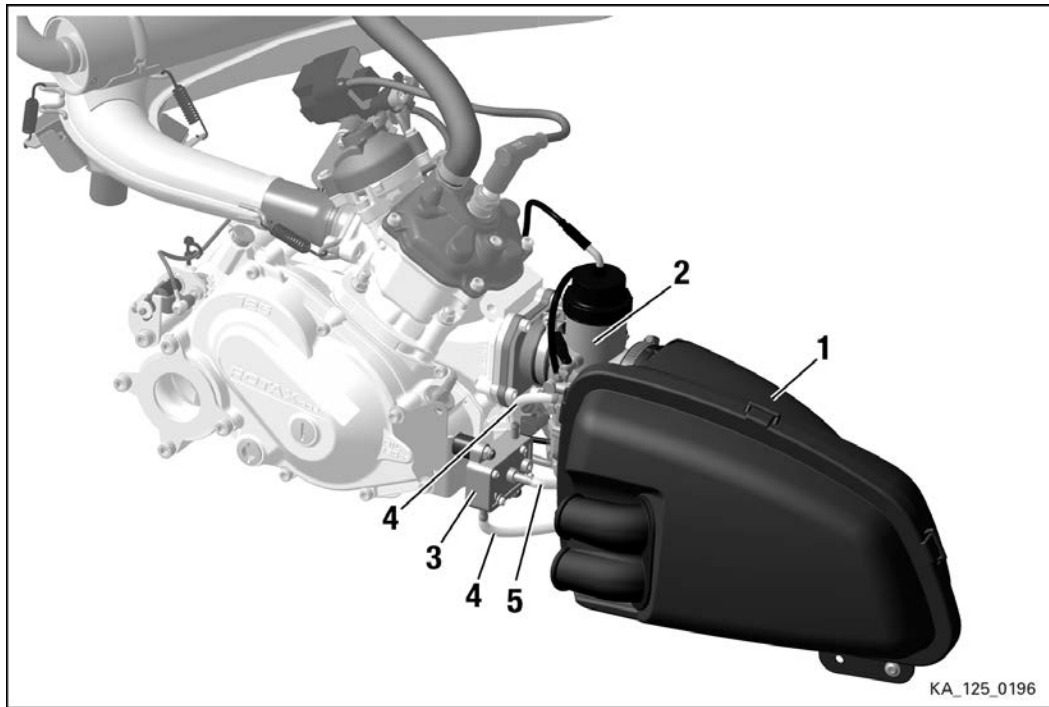

Figure 6.1: Position on engine

- | | |
|-------------------|--------------|
| 1 Intake silencer | 2 Carburetor |
| 3 Fuel pump | 4 Fuel line |
| 5 Impulse pipe | |

REMOVAL OF THE CARBURETOR AND INTAKE SILENCER

Safety instructions

⚠ WARNING

Danger of explosion and ignition!

Overflowing and spoilt gasoline must be absorbed immediately with a binding agent and correctly disposed. Do not work with open flames and sources of ignition. Fuel must not come into contact with hot parts such as engine or exhaust since this may cause a fire!.

Preparation

The following preparations should be carried out before removing the components: See [Figure: Carburetor and intake silencer](#).

1. Pull off fuel pipe between the fuel tank and fuel pump from the fuel pump (4) and seal it with a screw.
2. Remove the Bowden cable. See also Chapter 3).

REMOVAL OF THE CARBURETOR, INTAKE SILENCER

Instruction

See [Figure: Carburetor and intake silencer](#).

ATTENTION

Fuel may spill out when removing the carburetor.

ENVIRONMENTAL NOTE

Protect the environment!

Use a container to collect the fuel from the carburetor.

To remove the carburetor and intake silencer the following steps are required:

1. Remove the fuel line (1) between the fuel pump (3) and the carburetor.
2. Loosen the hose clamp (4).
3. Remove the carburetor along with the intake silencer (5).

BRP-Rotax
REPAIR MANUAL

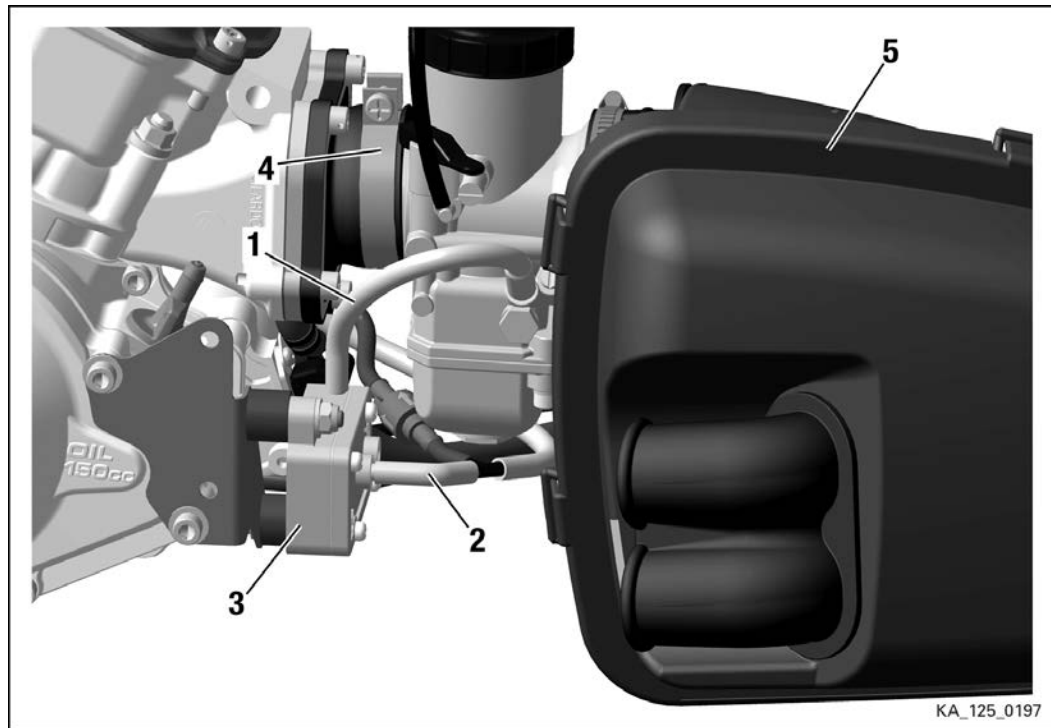

Figure 6.2: Carburetor and intake silencer

- | | |
|-------------------------------|-----------------|
| 1 Fuel line to the carburetor | 2 Impulse line |
| 3 Fuel pump | 4 Pipe clamp 51 |
| 5 Intake silencer | |

REMOVAL OF THE FUEL PUMP

Instruction See [Figure: Fuel pump](#).

To remove the fuel pump the following steps are required:

1. Remove the fuel pump (1) from the retaining plate (5).

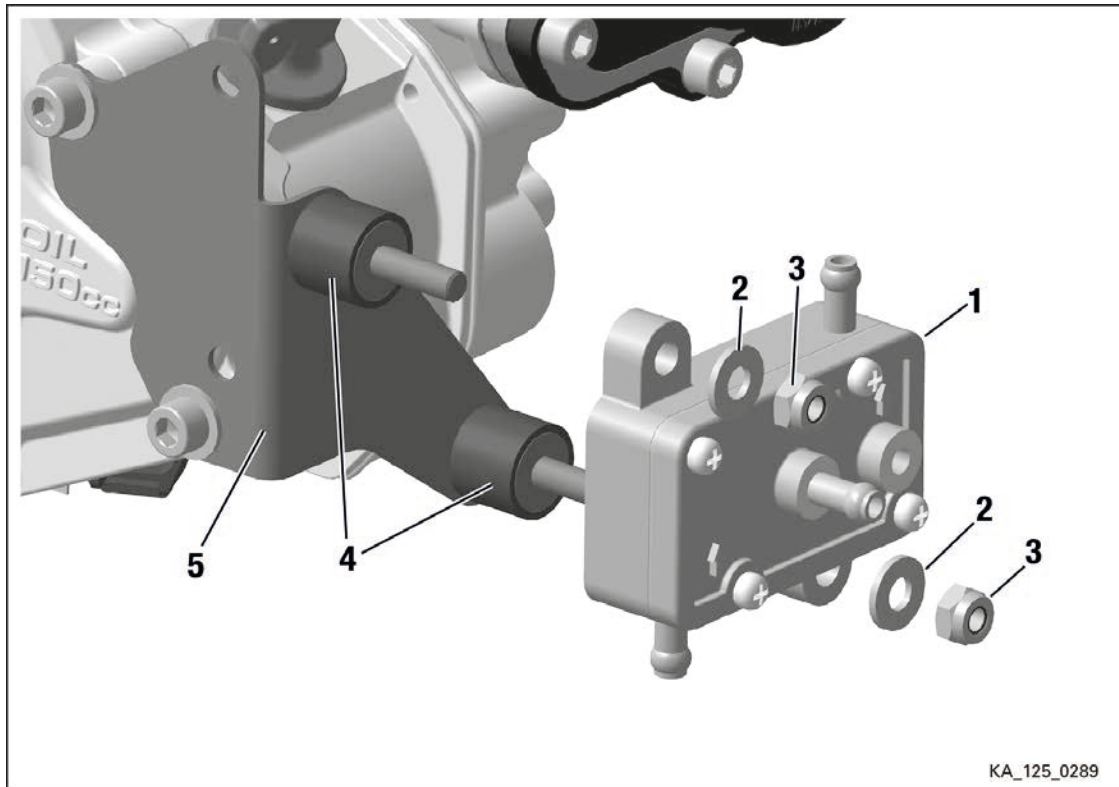

1 Fuel pump

2 Washer 6.4

3 Lock nut M6

4 Rubber buffer

5 Retaining plate

Figure 6.3: Fuel pump

DISASSEMBLY OF THE CARBURETOR

1. Disassembly of the carburetor to the parts shown in [Figure: Carburetor](#) and clean them with fuel.

BRP-Rotax
REPAIR MANUAL

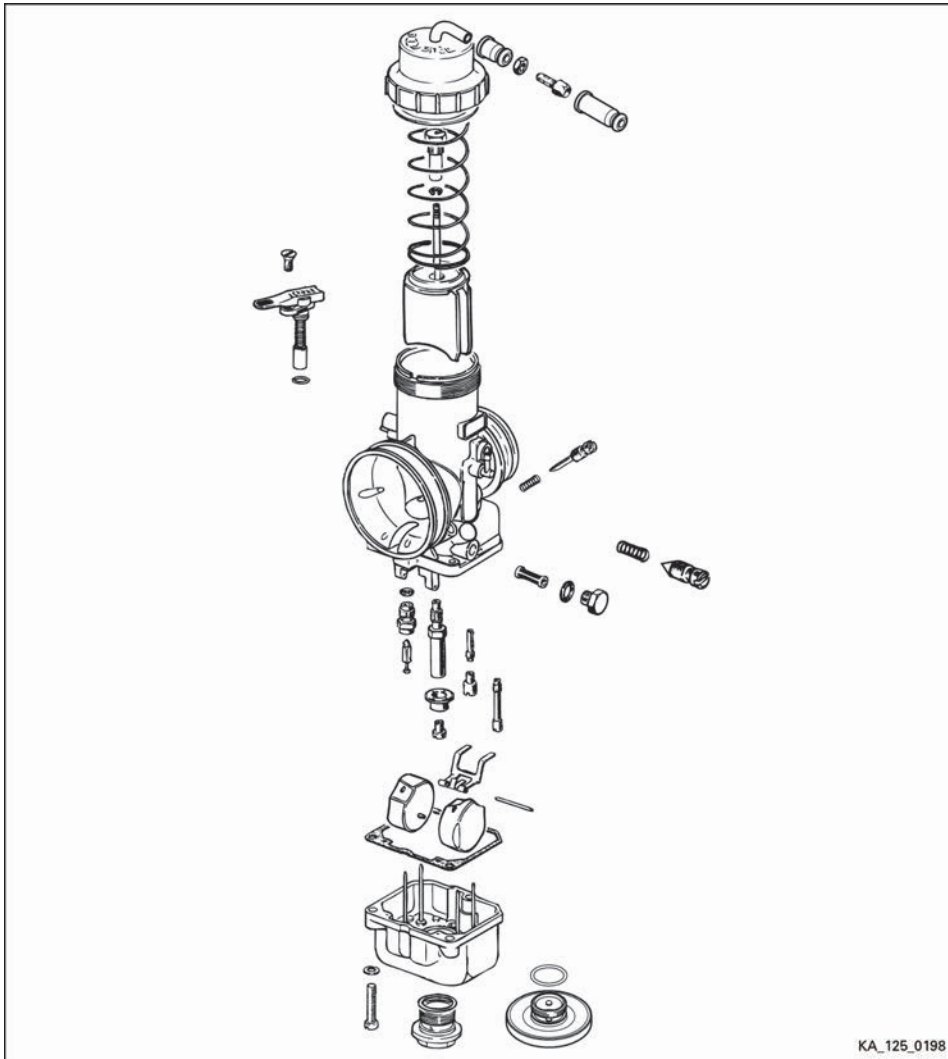

Figure 6.4: Carburetor

BRP-Rotax REPAIR MANUAL

DISASSEMBLY OF THE INTAKE SILENCER

Intake silencer See [Figure: Intake silencer](#).

1. Disassemble the intake silencer to the parts shown in following Figure.

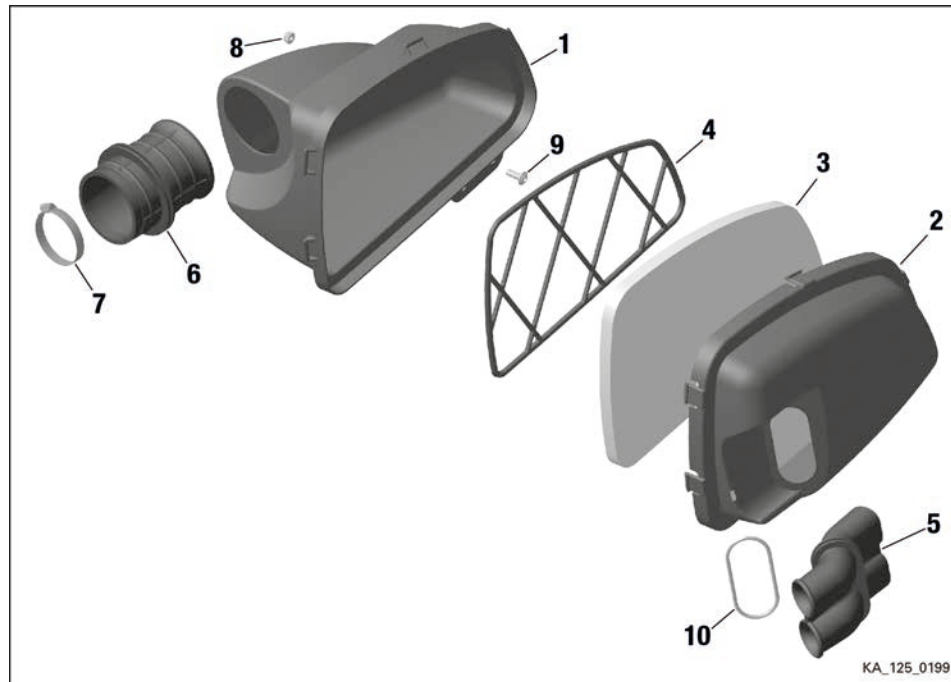

Figure 6.5: Intake silencer

- | | | | |
|---|---|----|------------------------|
| 1 | Intake silencer case | 2 | Intake silencer cover |
| 3 | Filter element | 4 | Filter element support |
| 5 | Intake silencer tube | 6 | Carburetor socket |
| 7 | Clamp 50–70 | 8 | Lock nut M6 |
| 9 | Allen screw with rounded flange head
M6x16 | 10 | O-ring 59.52x2.62 |

BRP-Rotax
REPAIR MANUAL

CARBURETOR AND INTAKE SILENCER – INSPECTION OF COMPONENTS

In the case of problems with the fuel supply the carburetor should be checked:
First the components should be cleaned and then inspected.

INSPECTION OF THE CARBURETOR

Instruction See [Figure: Carburetor](#).

1. Clean the fuel filter (1) and make sure that it is in good condition.
2. Blow compressed air through the holes in the carburetor housing (2) and the jets (3, 4, 5, 6 and 7) and make sure that there is no pollution to have an easy and free flow.
3. Check that the clip (8) is tightly seated on the jet needle (9).

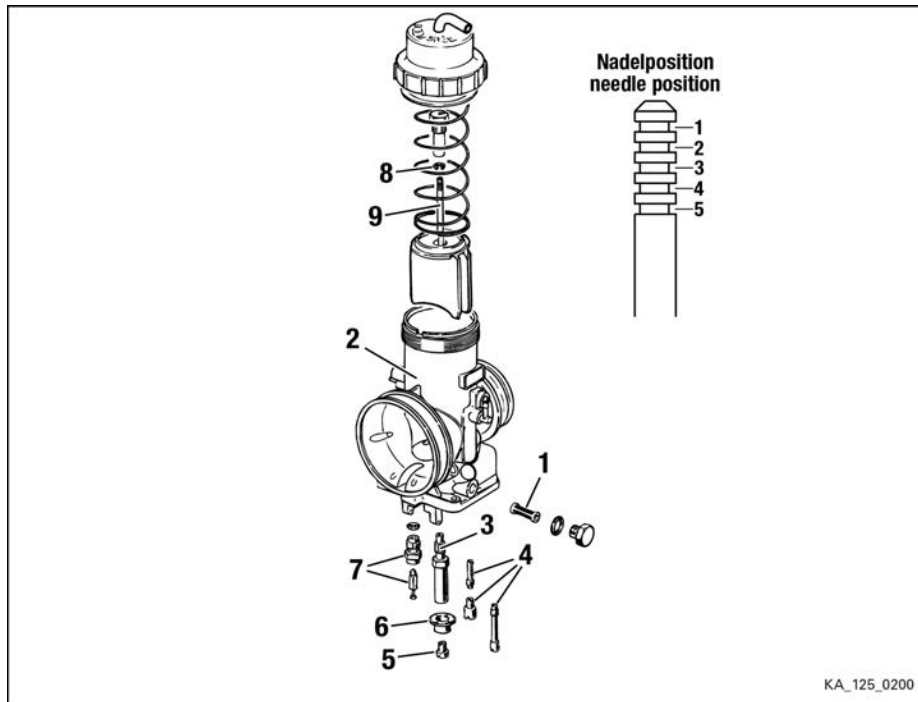

Figure 6.6: Carburetor

- | | |
|--|---------------------------|
| 1 Fuel filter | 2 Carburetor housing |
| 3 Needle jet DP 267 | 4 Idling and starter jets |
| 5 Main jet | 6 Main jet cup |
| 7 Needle valve 150 (standard) 200 (optional) | 8 Clip |
| 9 Jet needle K 57 | |

BRP-Rotax REPAIR MANUAL

INSPECTION OF THE FUEL PUMP

General

NOTE

Only the complete membrane and gasket set of the fuel pump can be replaced.

Fuel pump gasket set: Part no. 296165

Instruction

See [Figure: Fuel pump](#).

1. Check the condition of the impulse pipe (1), fuel line (2) and fuel overflow line (3) and in case of doubt replace them.

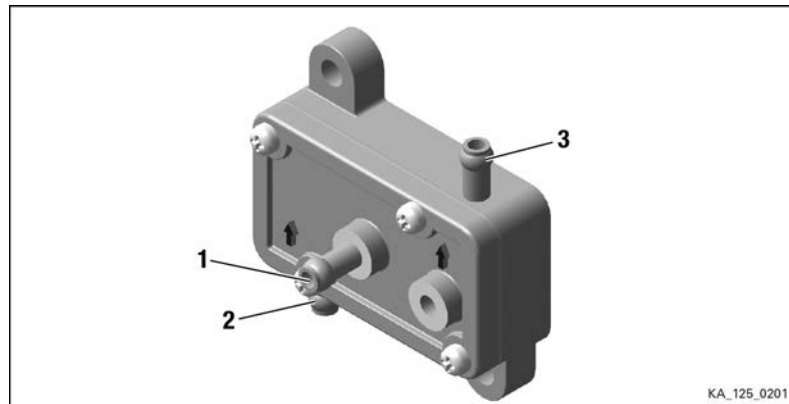

Figure 6.7: Fuel pump

1 Impulse pipe

2 Fuel line (from fuel tank)

3 Fuel line (to carburetor)

INSPECTION OF THE INTAKE SILENCER

General

ATTENTION

A damaged filter element must be replaced immediately. Otherwise dirt particles can enter the intake and cause damage to the engine.

Instruction

See [Figure: Intake silencer](#).

1. Inspect the silencer housing (1) and silencer cover (2) for cracks.
2. Inspect the intake silencer tube (5) and carburetor socket (6) for cracks or porosity.
3. Clean the filter element (3) with filter cleaner and oil it afterwards slightly with air filter oil.
4. Inspect the filter element (3) for cracks.

BRP-Rotax REPAIR MANUAL

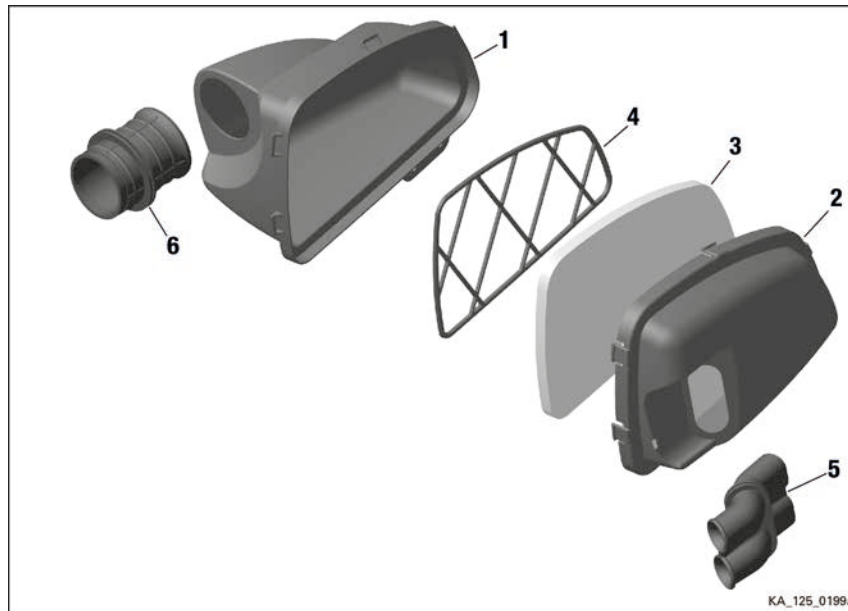

Figure 6.8: Intake silencer

- | | | | |
|---|-----------------------------|---|-------------------------------|
| 1 | <i>Intake silencer case</i> | 2 | <i>Intake silencer cover</i> |
| 3 | <i>Filter element</i> | 4 | <i>Filter element support</i> |
| 5 | <i>Intake silencer tube</i> | 6 | <i>Carburetor socket</i> |
-

INSTALLING THE CARBURETOR AND INTAKE SILENCER

ASSEMBLY OF CARBURETOR

Instruction **NOTE**

Use ROTAX® gasket set, part no. 293834.

1. Assemble the components in the opposite succession as you disassembled them. See also Chapter 6) section: Disassembly of the carburetor.

ASSEMBLY OF FLOAT HOUSING

General **NOTE**

The tips of the bracket must be at the same height. Adjust them if necessary. In this check the float chamber should not have been fitted.

Instruction The following steps are required to install the float housing:

See [Figure: Float chamber](#)

1. Check the position of the float attachment (1) in its installed state.
2. When the floats (2) are inserted you should be able to see the word "ALTO" on their top surfaces.
3. Install and adjust the Bowden cable in accordance with the operating instructions.
4. Set the idle adjuster screw (3) and adjustment screw kit (4).

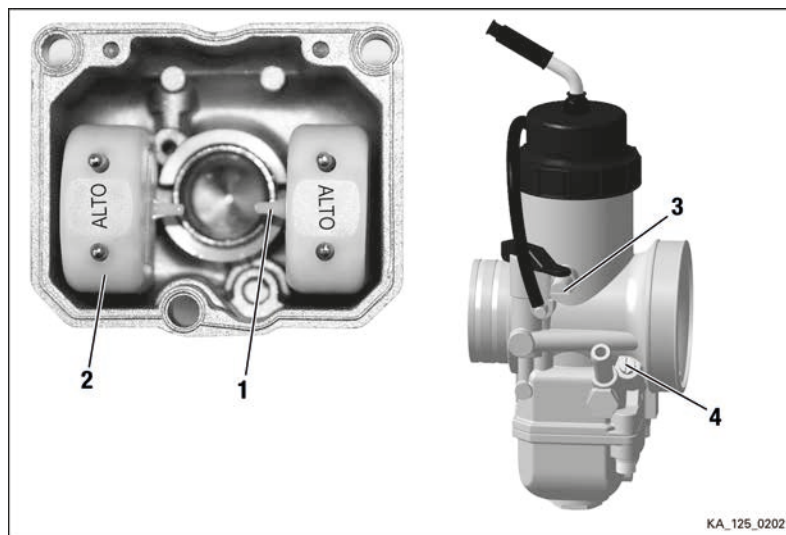

Figure 6.9: Float chamber

1 *Float attachment*

2 *Float 4.0*

3 *Adjustment screw*

4 *Adjustment screw kit*

BRP-Rotax REPAIR MANUAL

ASSEMBLY OF INTAKE SILENCER

General

NOTE

Before assembly, first immerse the filter element in filter oil. Squeeze out excess oil.

Instruction

The following steps are required to install the intake silencer:

1. Assemble the components in the opposite succession as you disassembled them. See also Chapter 6. section: Disassembly of the intake silencer.

INSTALLATION OF FUEL PUMP, CARBURETOR

Safety instructions

⚠ WARNING

Danger of explosion and ignition!

Overflowing and spoilt gasoline must be absorbed immediately with a binding agent and correctly disposed. Do not work with open flames and sources of ignition. Fuel must not come into contact with hot parts such as engine or exhaust since this may cause a fire!

NOTE

When assembling the parts make sure that the pipes are connected to the correct terminal!

Preparation The following preparations should be carried out before installing the components:

Installation of fuel pump

➔ Install the fuel pump (8) with 2 rubber buffer and new lock nuts with washers.

Instruction To install the carburetor and intake silencer the following steps are required:

See [Figure: Carburetor and intake silencer](#).

1. Pull the hose clamp (3) over the carburetor flange.
2. Push the carburetor (1) onto the carburetor flange (2) and fasten the hose clamp (3).
3. Secure the intake silencer (4) with the hose clamp (5) on the carburetor.
4. Check the Bowden cable (6) for wear, especially where it bends. Bends can cause the throttle to be stuck in fully open. See Chapter 9.
5. Connect the fuel feed line (5) and Bowden cable (6) to the carburetor.
6. Connect the impulse pipe (7).

Chapter: Chapter 7
CENTRIFUGAL CLUTCH, PRIMARY AND BALANCE DRIVE

TOPICS IN THIS CHAPTER

System description	2
Removal of the centrifugal clutch assy.....	4
Drain oil	4
Removal of centrifugal clutch, primary and balance drive	5
Centrifugal clutch assy. – inspection.....	10
Inspection of clutch and starter gear.....	10
Check the thrust washers, O-rings and needle cage.....	10
Inspection of starter reduction gear	11
Inspection of gears	12
Inspection of clutch cover	12
Centrifugal clutch assy. – installation.....	14
Installation of starter reduction gear	14
Installation of balance gear, starter gear and clutch plate.....	15
Installation of balance gear.....	15
Installation of starter gear	16
Installation of clutch plate	17
Installation of clutch drum and secondary gear.....	18
Installation of support plate and clutch cover.....	20
Filling the gear housing with oil.....	21

Contents

This chapter describes the disassembly and assembly of the centrifugal clutch and the primary and balance drive for the ROTAX® 125 MAX DD2 evo engine. The description is broken down into subsections.

SYSTEM DESCRIPTION

Overview

Position on engine

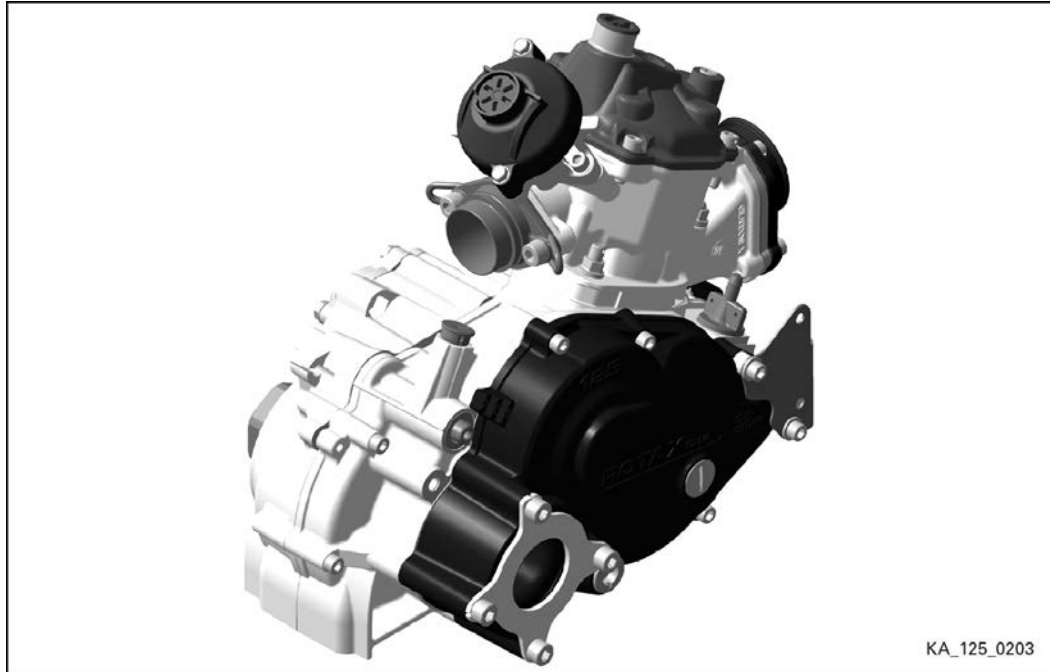
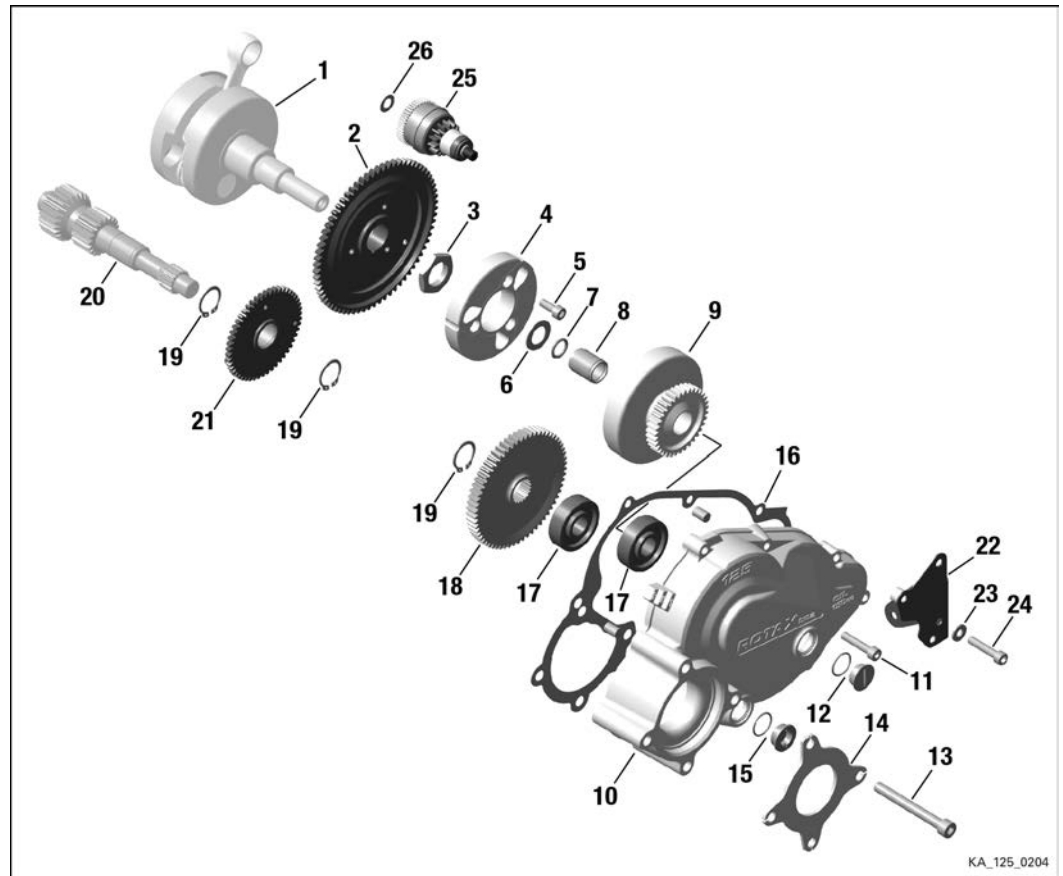

Figure 7.1: Position on engine

BRP-Rotax REPAIR MANUAL



KA_125_0204

Figure 7.2

1 Crankshaft assy.	2 Starter gear 70 T	3 Hex. nut M22x1.5
4 Clutch	5 Allen screw M6x16	6 Thrust washer 15.2/25/1
7 O-ring 12x2.5	8 Needle cage 15x19x24	9 Clutch primary drive gear
10 Clutch cover, black coated	11 Allen screw M6x30	12 Plug screw M18x1.5
13 Allen screw M8x70	14 Support plate	15 Oil level screw M18x1.5
16 Gasket	17 Ball bearing 6302	18 Secondary gear
19 Retaining ring with lug 20x1.2	20 Primary shaft 24/19 T	21 Balance gear 50 T assy.
22 Retaining plate assy.	23 Washer 6.4	24 Allen screw M6x40
25 Starter reduction gear assy.	26 Thrust washer 8.5/15/0.5	

REMOVAL OF THE CENTRIFUGAL CLUTCH ASSY.

Safety instructions

⚠ WARNING

Danger of severe burns and scalds! Always allow the engine to cool down to ambient temperature before starting any work.

⚠ WARNING

Danger of explosion and ignition!

Overflowing and split gasoline must be absorbed immediately with a binding agent and correctly disposed of. Do not work with open flames and sources of ignition. Fuel must not be allowed to come into contact with hot engine parts and components.

DRAIN OIL

Instruction

See [Figure: Drain oil.](#)

1. Remove the Magnetic drain plug (1) with gasket (2) from the crankcase and gearbox housing.
2. Drain the oil into a suitable vessel and dispose of it in the proper manner.

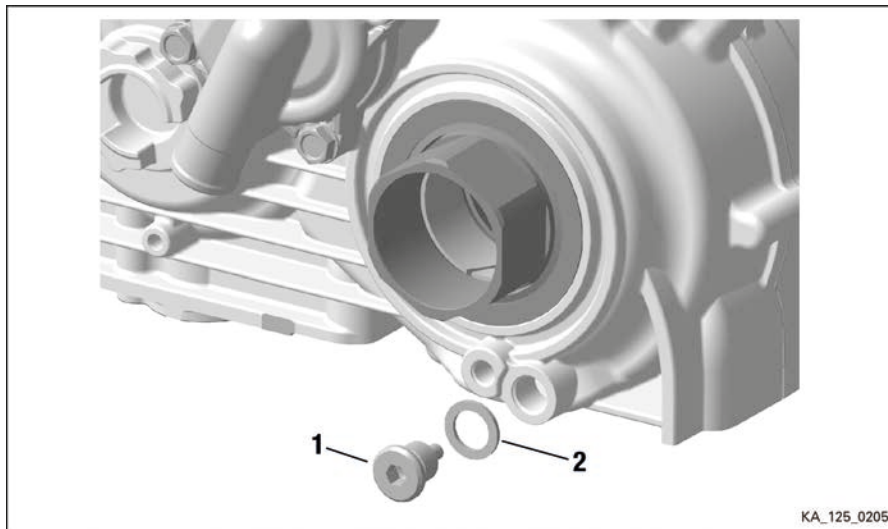

Figure 7.3: Drain oil

1 Magnetic drain plug M12x1.5

2 Gasket

BRP-Rotax REPAIR MANUAL

REMOVAL OF CENTRIFUGAL CLUTCH, PRIMARY AND BALANCE DRIVE

Special tools The following special tools/equipment are required.

Part number	Designation	Field of application
276016	Puller assy.	Starter gear
676202	Fixation tool	Starter gear

Instruction See [Figure: Clutch cover](#).

1. Loosen the 4 Allen screws M6x30 (1), 2 Allen screws M6x40 (4) include washer and retaining plate on the clutch cover (7).
2. Loosen the 4 Allen screws M8x70 (2) and remove them along with the support plate (3) .
3. Remove the clutch cover (7).
4. Remove the gasket (8).

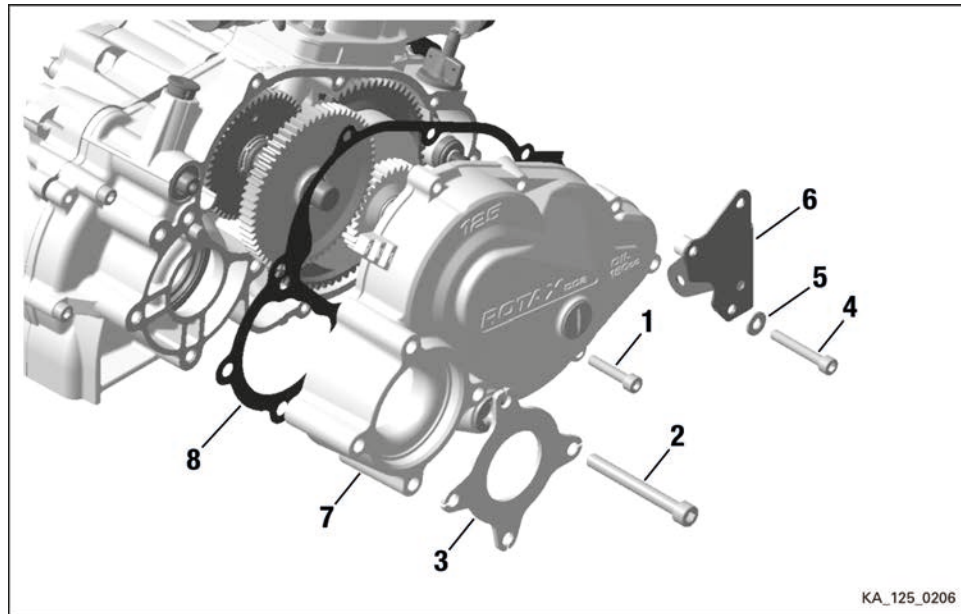

Figure 7.4: Clutch cover

- | | |
|------------------------------|-------------------------|
| 1 Allen screw M6x30 | 2 Allen screw M8x70 |
| 3 Support plate | 4 Allen screw M6x40 |
| 5 Washer 6.4 | 6 Retaining plate assy. |
| 7 Clutch cover, Black coated | 8 Gasket |

BRP-Rotax REPAIR MANUAL

Instruction See [Figure: Primary-Secondary gears](#).

5. Remove the secondary gear (2) and clutch primary drive gear (1).
6. Remove the retaining ring (4) from the primary shaft (3) using circlip pliers.

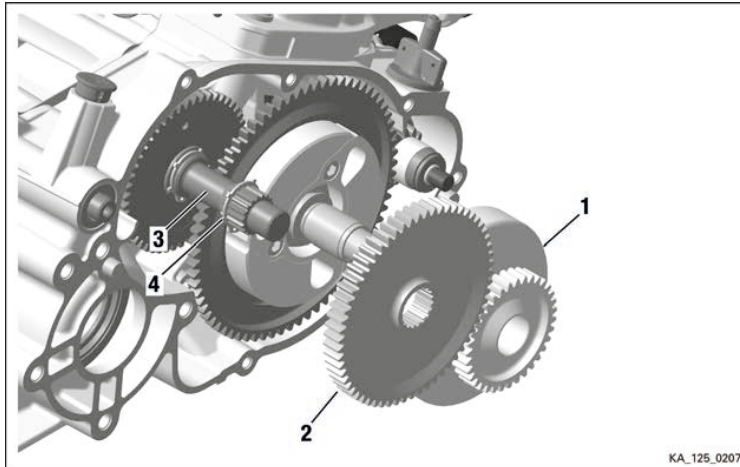

Figure 7.5: Primary — Secondary gears

- | | |
|--------------------------------|-------------------------|
| 1 Clutch w. primary drive gear | 2 Secondary gear |
| 3 Primary shaft | 4 Retaining ring 20x1.2 |

Instruction See [Figure 7.4: Figure: Clutch cover](#).

7. Remove the needle cage (1) along with the O-ring (2) and thrust washer (3) from the crankshaft (4).

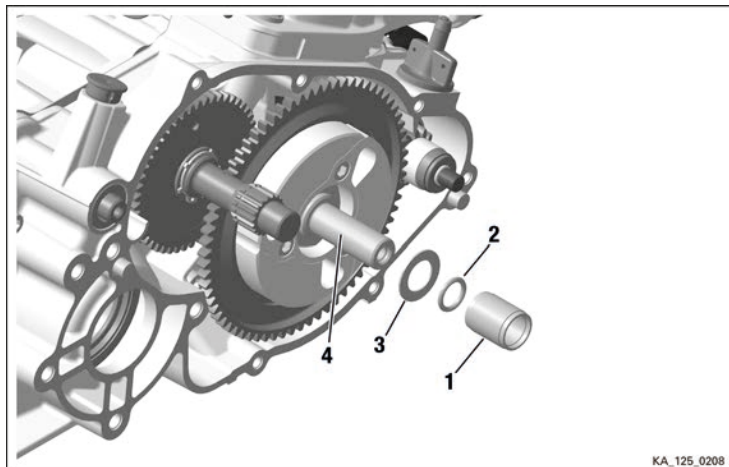

Figure 7.6: Clutch cover

BRP-Rotax REPAIR MANUAL

- | | |
|---------------------------|--------------------|
| 1 Needle cage 15x19x24 | 2 O-ring 12x2.5 |
| 3 Thrust washer 15.2/25/1 | 4 Crankshaft assy. |
-

Instruction See [Figure: Clutch plate](#).

8. Block the starter gear (1) using the fixation tool part no. 676202 (2).
9. Loosen the 3 Allen screws M6x16 (4) and remove the clutch plate (3) using a flathead screwdriver.

NOTE

Screws are stuck in with LOCTITE 648, and can (if necessary) therefore first be heated with a heat gun.

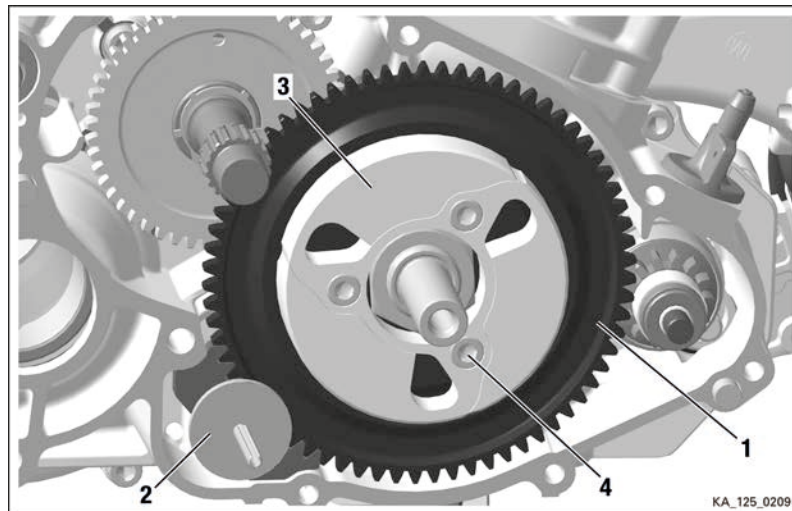

Figure 7.7: Clutch plate

- | | |
|---------------------|---------------------|
| 1 Starter gear 70 T | 2 Fixation tool |
| 3 Clutch plate | 4 Allen screw M6x16 |
-

Instruction See [Figure: Clutch cover](#).

10. Loosen the hex nut M22x1.5 (3) using a flathead screwdriver.

NOTE

The hex nut is stuck in with LOCTITE 648, and must therefore first be heated with a heat gun.

BRP-Rotax REPAIR MANUAL

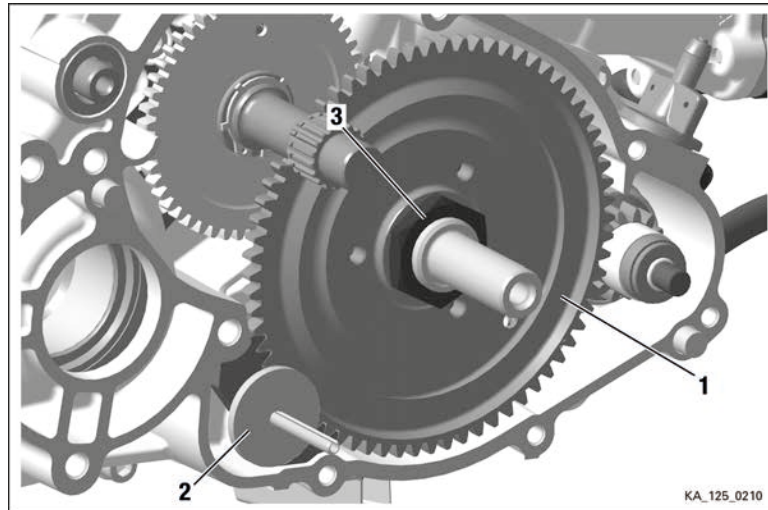

Figure 7.8: Clutch cover

- 1 Starter gear
- 2 Fixation tool
- 3 Hex. nut M22x1.5

Instruction

See [Figure: Special tool](#).

11. Pull the starter gear off the crankshaft using the special tool part no. 276016.

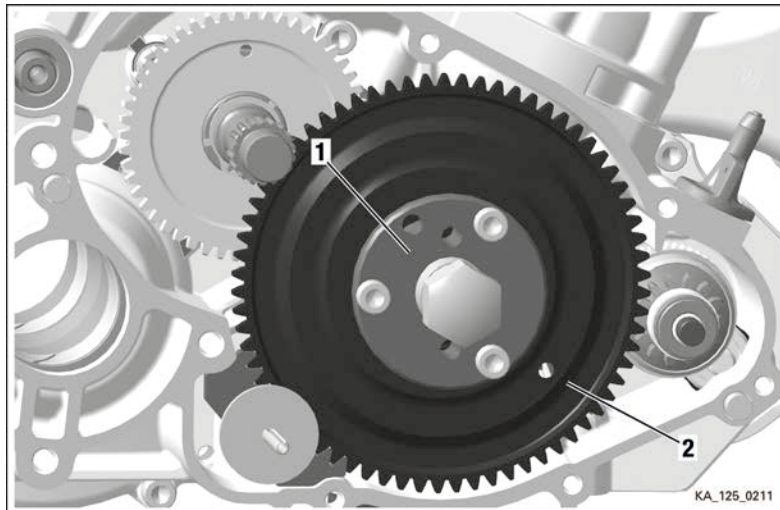

Figure 7.9: Special tool

- 1 Special tool part no. 276016 (Puller assy.)
- 2 Starter gear

BRP-Rotax REPAIR MANUAL

Instruction See [Figure: Starter reduction gear](#).

12. Remove the starter reduction gear (1) along with the thrust washer (2).

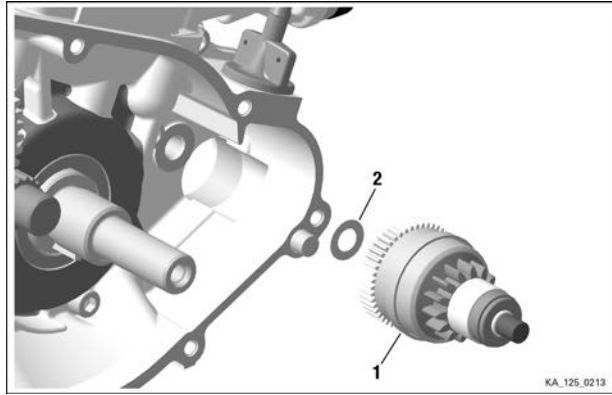

Figure 7.10: Starter reduction gear

1 Starter reduction gear

2 Thrust washer

Instruction See [Figure: Balance gear](#)

13. Remove the shaft retaining ring (2) from the balance gear using circlip pliers.
14. Remove the balance gear (1).
15. Remove the third shaft retaining ring (3) from the primary shaft.

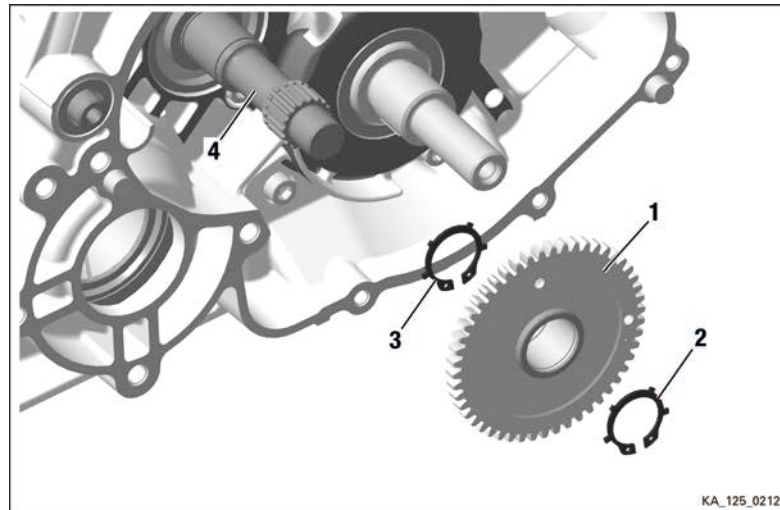

Figure 7.11: Balance gear

1 Balance gear 50 Z

2 Retaining ring 20x1.2

3 Retaining ring 20x1.2

CENTRIFUGAL CLUTCH ASSY. – INSPECTION

INSPECTION OF CLUTCH AND STARTER GEAR

Preparation See [Figure: Clutch plate](#).

1. Check the clutch plate.

NOTE

Thickness of clutch arm –24.10 mm (0.95 in.)

Thickness of clutch plate – min. 14.45 mm (0.57 in.)

2. Check the teeth on the starter gear for damage.
3. Remove any residue of LOCTITE adhesive from the starter gear

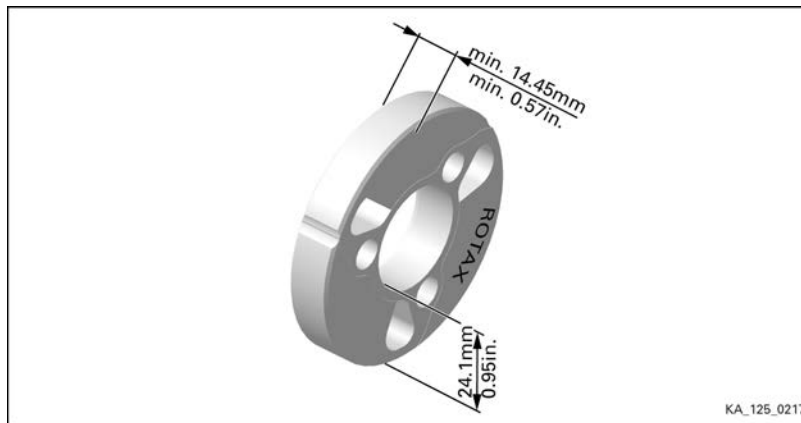

Figure 7.12: Clutch plate

CHECK THE THRUST WASHERS, O-RINGS AND NEEDLE CAGE

Instruction See [Figure: Clutch drum](#).

1. Inspect the thrust washers (1) and O-rings (2) for signs of wear and replace them if necessary.
2. Inspect the needle cage (3) for sign of wear and replace if necessary.

BRP-Rotax REPAIR MANUAL

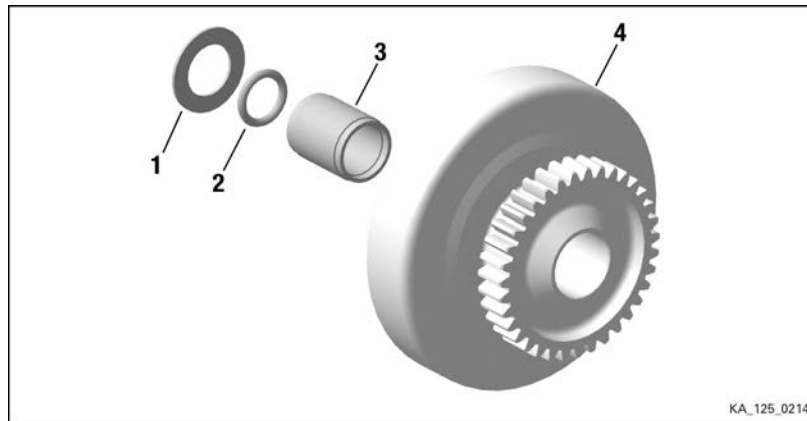

Figure 7.13: Clutch drum

- | | |
|---------------------------|--------------------------------|
| 1 Thrust washer 15.2/25/1 | 2 O-ring 12x2.5 |
| 3 Needle cage 15x19x24 | 4 Clutch w. primary drive gear |

INSPECTION OF STARTER REDUCTION GEAR

Instruction See [Figure: Starter reduction gear](#).

1. Clean the starter reduction gear assy. (1).
2. Checking that the starter reduction gear can move freely.

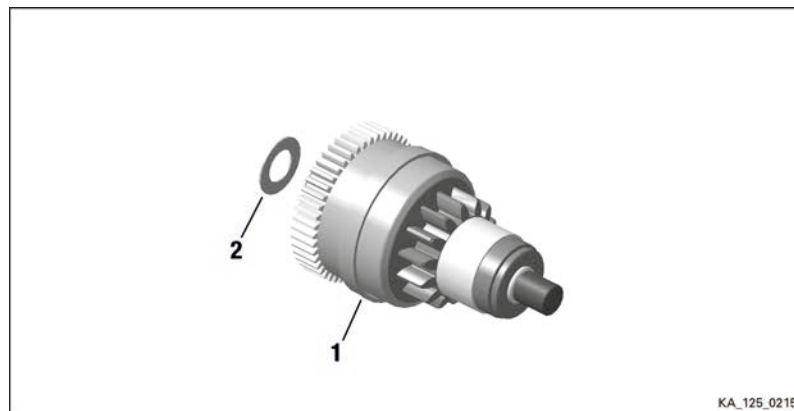

Figure 7.14: Starter reduction gear

- | | |
|--------------------------------|----------------------------|
| 1 Starter reduction gear assy. | 2 Thrust washer 8.5/15/0.5 |
|--------------------------------|----------------------------|

BRP-Rotax REPAIR MANUAL

INSPECTION OF GEARS

Instruction See [Figure: Gears](#).

1. Check the teeth on the illustrated components for damage, pitting and deformation.

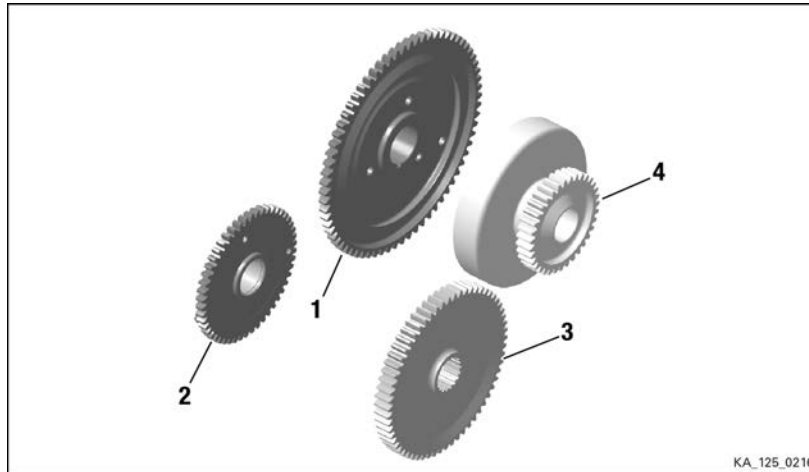

Figure 7.15: Gears

- | | |
|---------------------|--------------------------------|
| 1 Starter gear 70 T | 2 Balance gear |
| 3 Secondary gear | 4 Clutch w. primary drive gear |
-

INSPECTION OF CLUTCH COVER

Instruction See [Figure: Clutch plate](#).

1. See Chapter 5 – proceed initially as in Section: Installing of shafts and wheels.
2. Check the halves of the housing.
3. Check the bearings (2) and if necessary replace the bearings.

BRP-Rotax REPAIR MANUAL

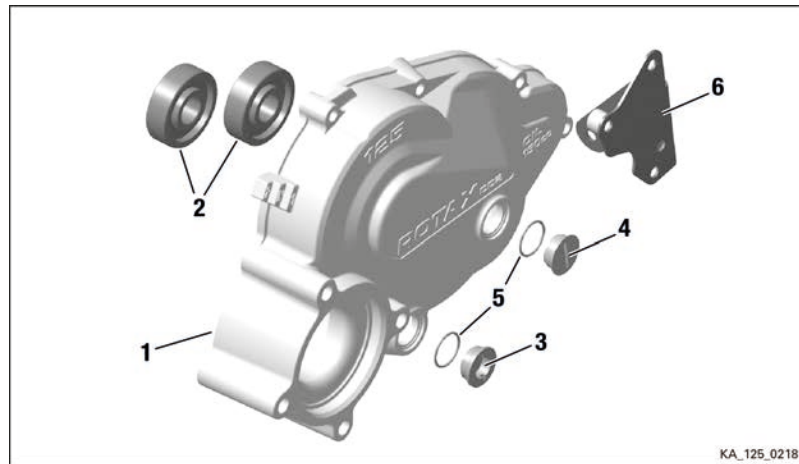

Figure 7.16: Clutch plate

- | | |
|------------------------------|-------------------------|
| 1 Clutch cover, black coated | 2 Ball bearing 6302 |
| 3 Oil level screw M18x1.5 | 4 Plug screw M18x1.5 |
| 5 O-ring 17x1.5 | 6 Retaining plate assy. |
-

CENTRIFUGAL CLUTCH ASSY. – INSTALLATION

General

NOTE

*The correct sequence **MUST** be followed. Once the starter gear has been installed it is no longer possible to install the starter reduction gear.*

INSTALLATION OF STARTER REDUCTION GEAR

Special tools

The following special tools/equipment are required:

Part number	Designation	Field of application
897330	Lithium-based grease	Starter reduction gear

Instruction

See [Figure: Starter reduction gear](#).

1. Insert the thrust washer (2) along with the starter reduction gear into the bearing point of the housing.
2. Grease the starter reduction gear assy. (1) with lithium-based grease in the area around the bearing points.

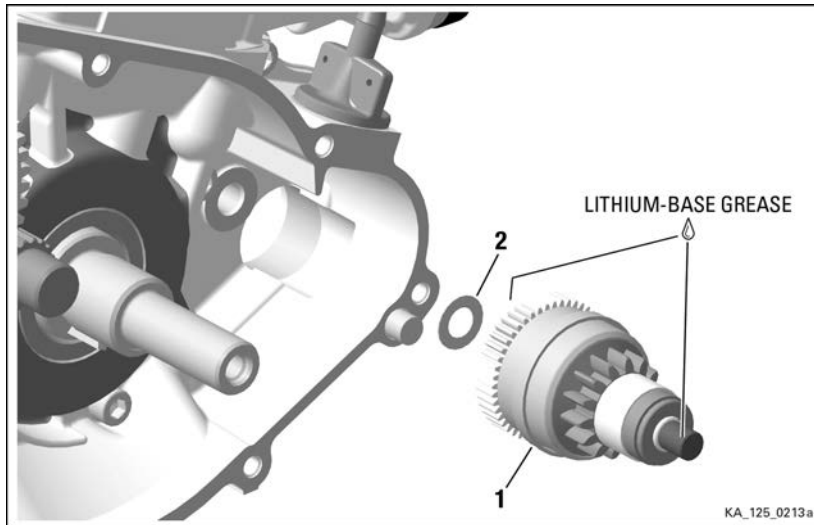

Figure 7.17: Starter reduction gear

1 Starter reduction gear assy.

2 Thrust washer 8.5/15/0.5

INSTALLATION OF BALANCE GEAR, STARTER GEAR AND CLUTCH PLATE

Special tools The following special tools/equipment are required

Part number	Designation	Field of application
n.a.	Circlip pliers	Shaft retaining rings
676202	Fixation tool	Starter gear
899788	LOCTITE 648	Starter gear

INSTALLATION OF BALANCE GEAR

Instruction See [Figure: Balance gear](#).

1. Fit the shaft retaining ring (3) on position 3 using the circlip pliers.
2. Insert the balance gear (1) onto the primary shaft (4).
3. Fit the outer shaft retaining ring (2) on position 2 using the circlip pliers.

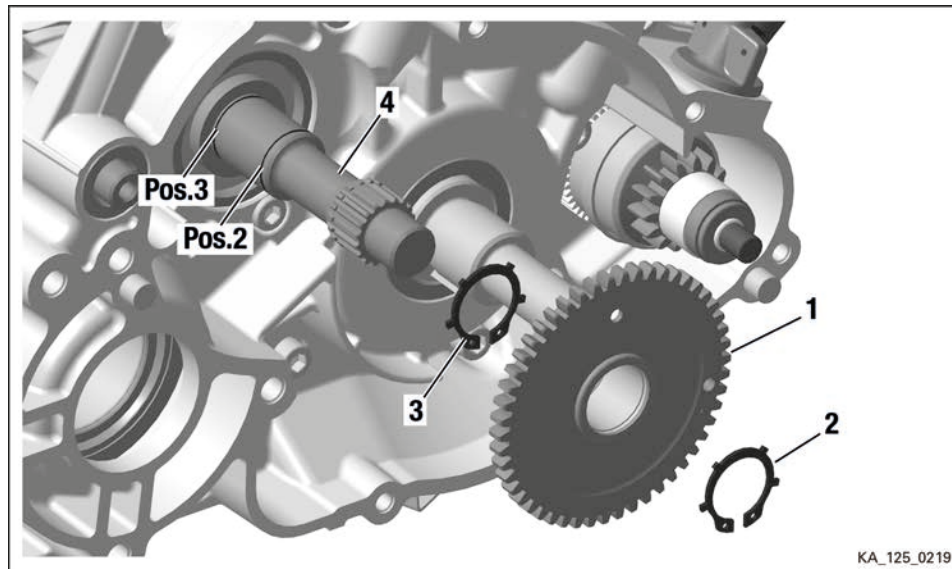

Figure 7.18: Balance gear

- 1 Balance gear
3 Shaft retaining ring 3

- 2 Shaft retaining ring 2
4 Primary shaft

BRP-Rotax REPAIR MANUAL

INSTALLATION OF STARTER GEAR

Instruction See [Figure: Starter gear](#).

1. Insert the starter gear (2) onto the crankshaft, take care to position it correctly in relation to the balance gear (1).

NOTE

Both components have a hole that has to overlap. This is to check the correct positioning of the gears.

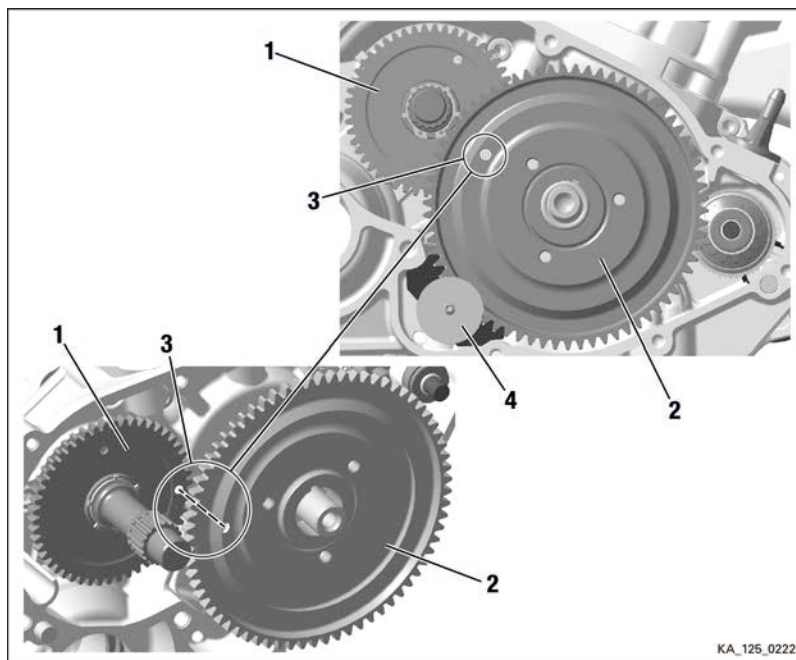

Figure 7.19: Starter gear

1 Balance gear 50 T

2 Starter gear 70 T

3 Markers

4 Fixation tool

Instruction See [Figure: Fixation tool](#).

2. Block the starter gear (2) using the fixation tool (4), part no. 676202.
3. Lubricate LOCTITE 648 on the Hex nut M22x1.5 SW 30 H=6 (3) and fit it using a suitable tool. Tightening torque 180 Nm.
4. Remove excess LOCTITE.

BRP-Rotax REPAIR MANUAL

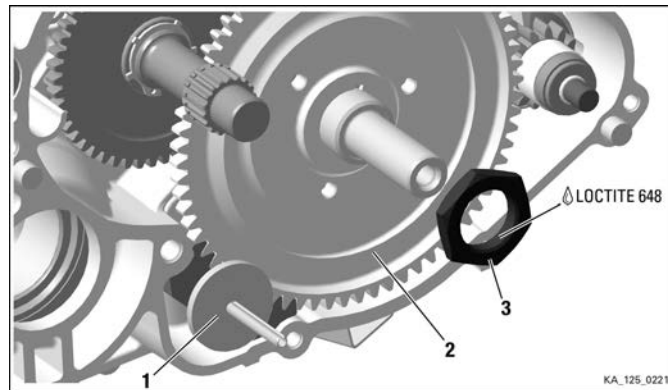

Figure 7.20: Fixation tool

- | | | | |
|---|-----------------|---|-------------------|
| 1 | Fixation tool | 2 | Starter gear 70 T |
| 3 | Hex.nut M22x1.5 | | |

INSTALLATION OF CLUTCH PLATE

Instruction See [Figure: Clutch](#).

1. Lubricate LOCTITE 648 on the new Allen screws M6x16 (2).
2. Insert the clutch (1) on and secure it with 3 Allen screws M6x16 (2). Tightening torque 17 Nm.

NOTE

Strength class of screws: 12.9!

3. Remove excess LOCTITE.

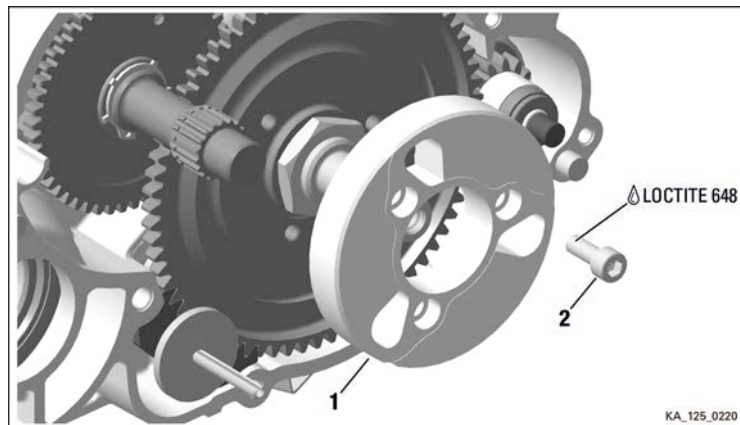

Figure 7.21: Clutch

- | | | | |
|---|--------|---|-------------------|
| 1 | Clutch | 2 | Allen screw M6x16 |
|---|--------|---|-------------------|

BRP-Rotax
REPAIR MANUAL

INSTALLATION OF CLUTCH DRUM AND SECONDARY GEAR

Special tools The following special tools/equipment are required:

Part number	Designation	Field of application
897330	Lithium-based grease	Needle cage

Instruction See [Figure: Clutch drum](#).

1. Slide the thrust washer (3) and O-ring (2) onto the crankshaft (4).
2. Lubricate lithium-based grease on the needle cage (1) and slide it onto the crankshaft.

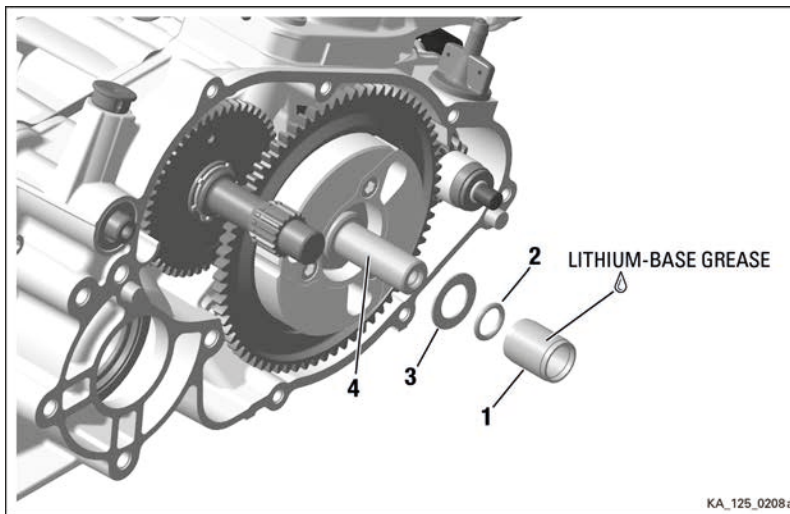

Figure 7.22: Clutch drum

- | | |
|---------------------------|--------------------|
| 1 Needle cage 15/19/24 | 2 O-ring 12x2.5 |
| 3 Thrust washer 15.2/25/1 | 4 Crankshaft assy. |

Instruction See [Figure: Secondary gear](#).

3. Slide the clutch primary drive gear (1) onto the crankshaft.
4. Fit the outer shaft retaining ring (4) on the primary shaft.
5. Engage the secondary gear (2) with the teeth on the primary shaft.

⚠ WARNING

Risk of fatal injury!

The engine must not be started without a clutch drum.

BRP-Rotax REPAIR MANUAL

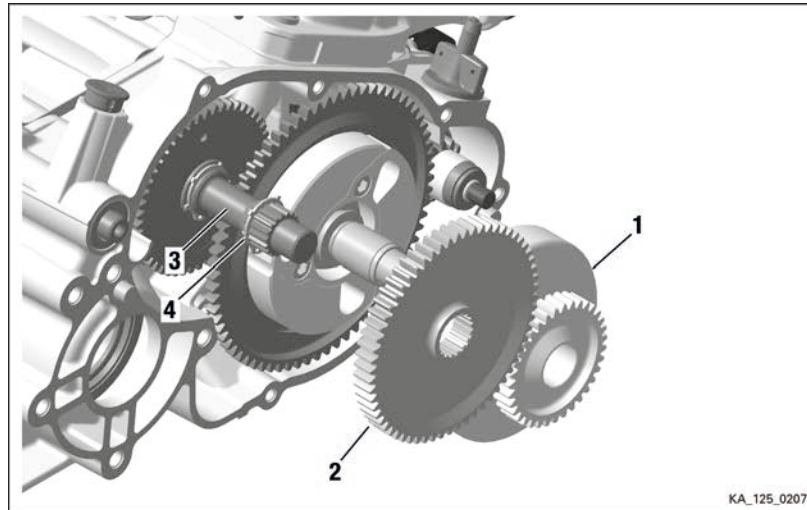

Figure 7.23: Secondary gear

- | | | | |
|---|----------------------------------|---|--------------------------------|
| 1 | <i>Clutch primary drive gear</i> | 2 | <i>Secondary gear</i> |
| 3 | <i>Primary shaft 24/19 T</i> | 4 | <i>Retaining ring with lug</i> |
-

BRP-Rotax
REPAIR MANUAL

INSTALLATION OF SUPPORT PLATE AND CLUTCH COVER

Special tools The following special tools/equipment are required:

Part number	Designation	Field of application
n.a.	Torque wrench	Clutch cover

Instruction See [Figure: Clutch cover, support plate](#).

1. Fit new gasket (8).
2. Fit the support plate (3) using 4 Allen screws M8x70 (2). Tightening torque 22 Nm.
3. Use 4 Allen screws M6x30 (1) to secure the clutch cover. Tightening torque 10 Nm.
4. Fit the retaining plate assy. (6) using 2 Allen screw M6x40 (4) with washer 6.4 (5). Tightening torque 10 Nm.

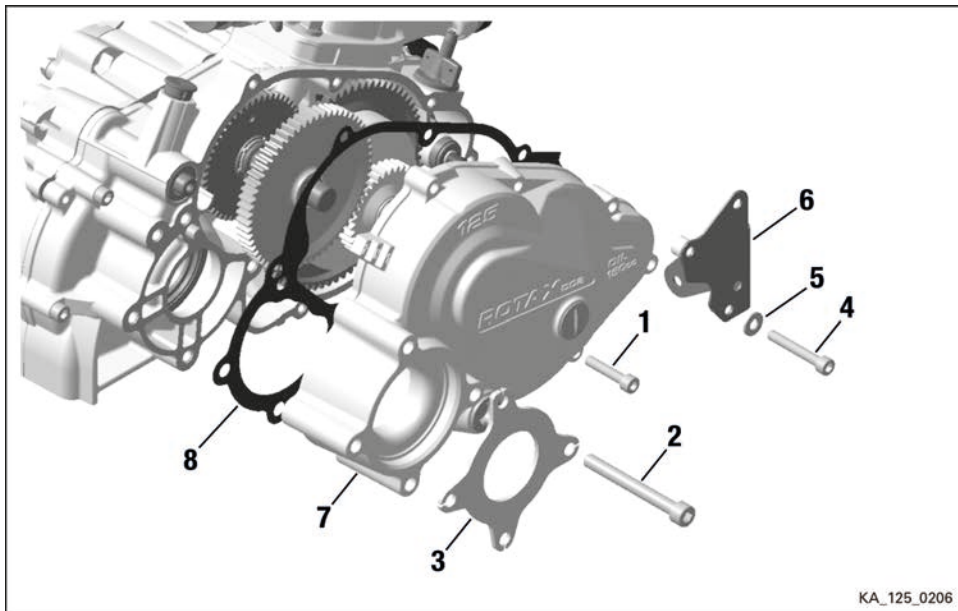

Figure 7.24: Clutch cover, support plate

- | | |
|------------------------------|-------------------------|
| 1 Allen screw M6x30 | 2 Allen screw M8x70 |
| 3 Support plate | 4 Allen screw M6x40 |
| 5 Washer 6.4 | 6 Retaining plate assy. |
| 7 Clutch cover, black coated | 8 Gasket |

FILLING THE GEAR HOUSING WITH OIL

General

NOTE

With the engine in a horizontal position pour in 150 ml of gear oil.

Special tools

The following special tools/equipment are required:

Part number	Designation	Field of application
25473	XPS® KART TEC DD2 KART GEAR OIL	Gear lubrication

Instruction

See [Figure: Gear housing](#).

1. Install the oil plug screw (1) with a new O-ring.
2. Install the oil level screw (2) with a new O-ring.
3. Remove the air vent screw (3) with O-ring (4).
4. Add the specified quantity (150 ml) of gear oil through the opening in the housing.
5. Replace the air vent screw (3) with a new O-ring (4).

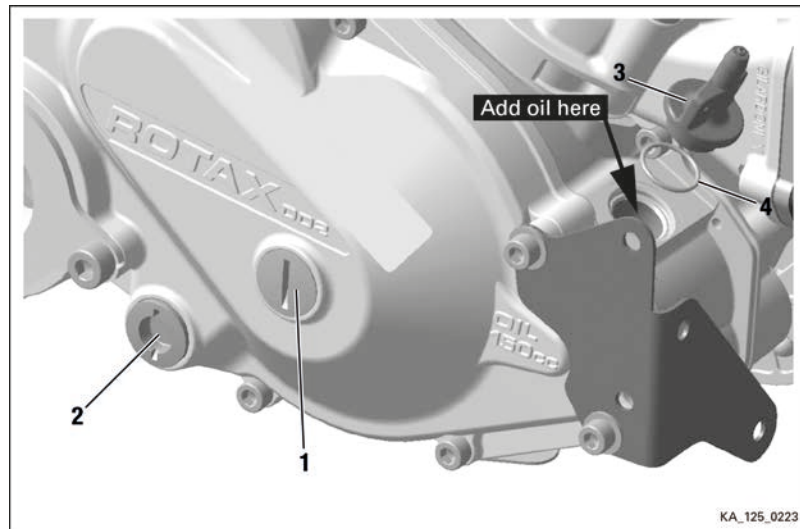

Figure 7.25: Gear housing

1 Plug screw M18x1.5

2 Oil level screw M18x1.5

3 Air vent screw M18x1.5

4 O-ring 17x1.5

BRP-Rotax
REPAIR MANUAL

NOTES

BRP-Rotax
REPAIR MANUAL

Chapter: Chapter 8
COOLING SYSTEM

TOPICS IN THIS CHAPTER

System description	2
Removal of radiator	4
Removal of radiator with cap assy.	4
Removal of water pump shaft	6
Inspection of cooling system	8
Radiator – inspection of components	8
Inspection of water pump shaft	9
Installing the radiator	10
Installation of radiator with cap assy.	10
Installing the water pump shaft	11
Replacing the oil seals on the water pump	11
Installation of water pump shaft	11
Final tasks	13

Contents This chapter describes the removal and installation of the cooling system for the ROTAX® 125 MAX DD2 evo engine. The description is broken down into subsections.

BRP-Rotax
REPAIR MANUAL

SYSTEM DESCRIPTION

Overview

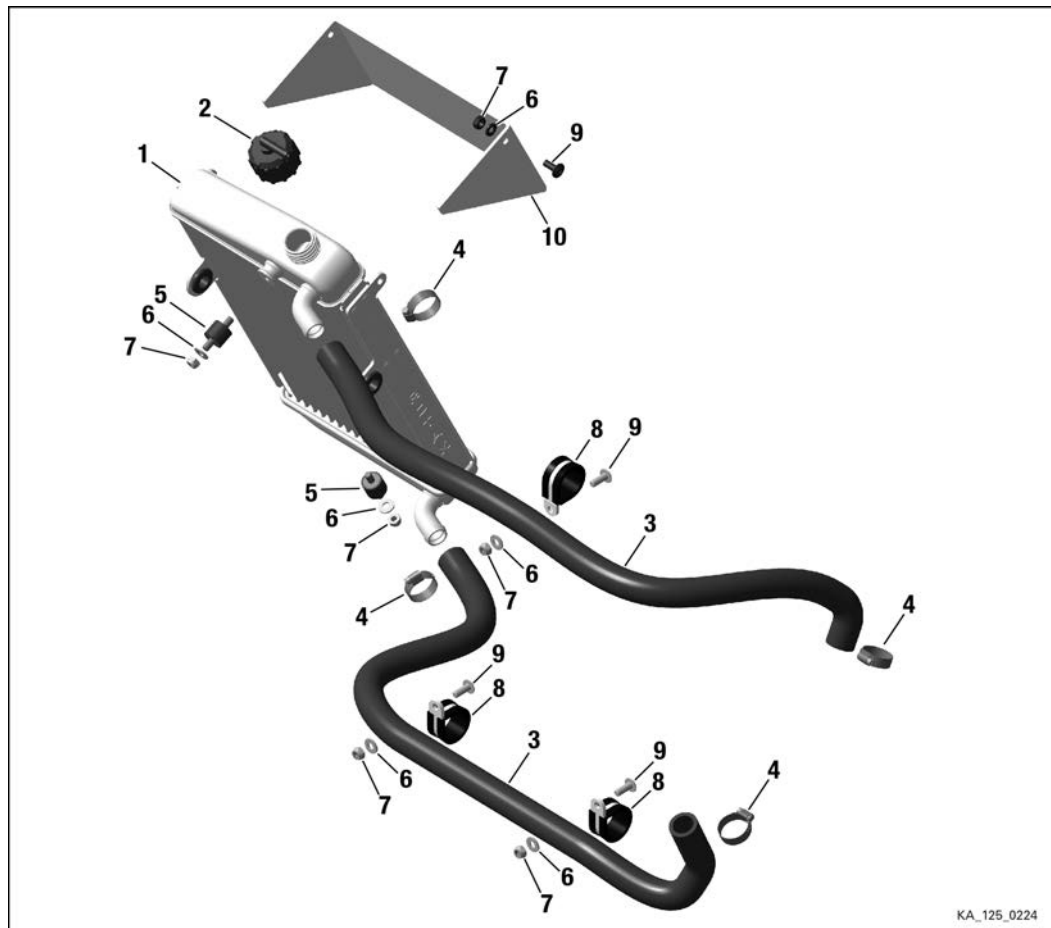

KA_125_0224

Figure 8.1: Radiator

- | | |
|---------------------------|-------------------------------|
| 1 Radiator | 2 Radiator cap with cap assy. |
| 3 Cooling water hose NW18 | 4 Clamp 16–25 |
| 5 Rubber buffer 18x15xM6 | 6 Washer 6.4 |
| 7 Lock nut M6 | 8 Cable clamp 26/M6 |
| 9 Allen screw M6x16 | 10 Windshield |

BRP-Rotax REPAIR MANUAL

Overview

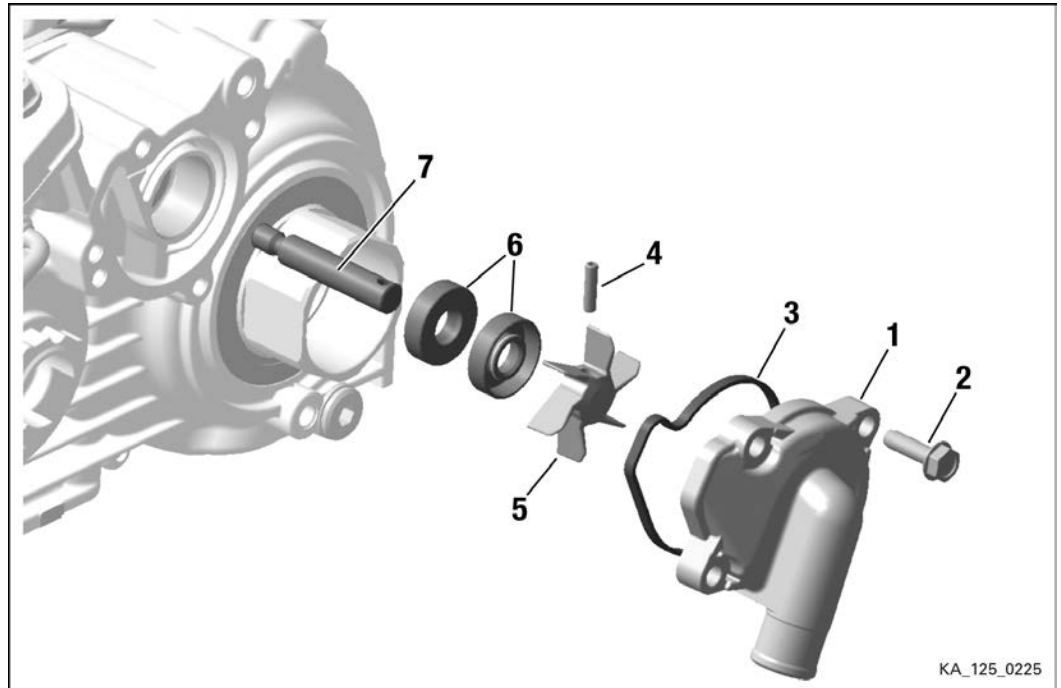

Figure 8.2: Water pump

- | | | | |
|---|--------------------------|---|--------------------------|
| 1 | Water pump housing | 2 | TAPTITE screw M6x20 (4x) |
| 3 | Rubber ring 61.5x1.5x3.5 | 4 | Dowel 4x16 |
| 5 | Impeller | 6 | Oil seal A 10x26x7 |
| 7 | Water pump shaft assy. | | |

REMOVAL OF RADIATOR

Safety instructions

⚠ WARNING

Danger of severe burns and scalds! Always allow the engine to cool down to ambient temperature before starting any work.

Preparation The following preparations should be carried out before removing the components:

1. Open the radiator cap.

REMOVAL OF RADIATOR WITH CAP ASSY.

Safety instruction

ENVIRONMENTAL NOTE

Please observe the disposal regulations applicable in your area.

General **NOTE**

Drain the engine coolant in a suitable container.

Instruction See [Figure: Radiator](#).

1. Unscrew the clamps (4). Disconnect the cooling water hose from the radiator. See also Chapter 8.
2. Disconnect the cooling water hose from the cylinder head cover (3).
3. Disconnect the cooling water hose from the water pump housing (2).

BRP-Rotax
REPAIR MANUAL

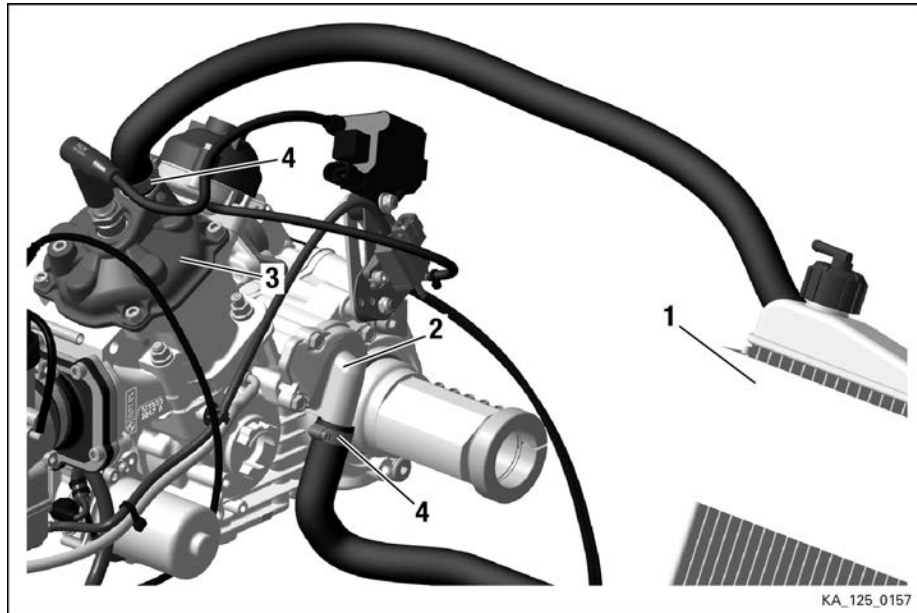

Figure 8.3: Radiator

- | | |
|---------------------------|----------------------|
| 1 Radiator with cap assy. | 2 Water pump housing |
| 3 Cylinder head cover | 4 Clamp 16–25 |
-

REMOVAL OF WATER PUMP SHAFT

General

NOTE

Collect the coolant in a suitable vessel.

Instruction

See [Figure: Water pump housing](#).

1. Remove the cooling water hose.
2. Release and remove the water pump housing (2) and rubber ring (3) from the housing via 4 TAPTITE screws (1).

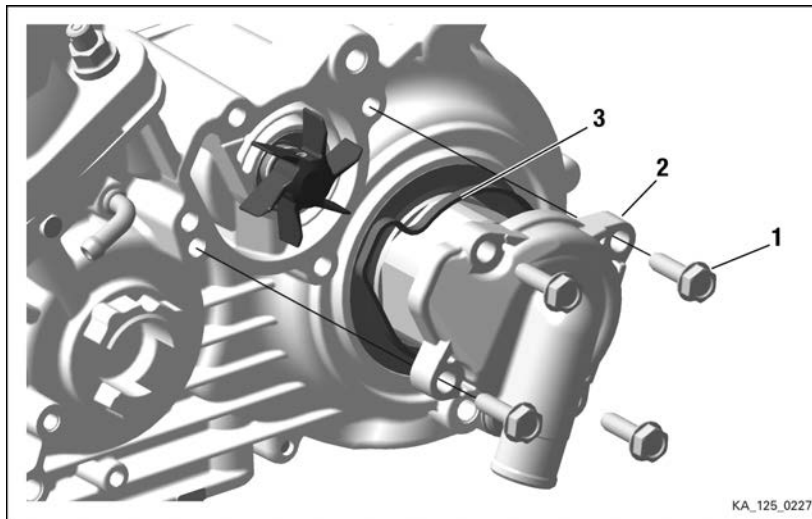

Figure 8.4: Water pump housing

1 TAPTITE screw M6x20

2 Water pump housing

3 Rubber ring 61.5x1.5x3.5

Instruction

See [Figure: Water pump shaft](#).

ATTENTION

Water pump shaft has a left hand thread!

3. Unscrew the water pump shaft (1) from the primary shaft. To do so, the primary shaft needs to be prevented from rotation.
4. Remove the two oil seals (2).

BRP-Rotax REPAIR MANUAL

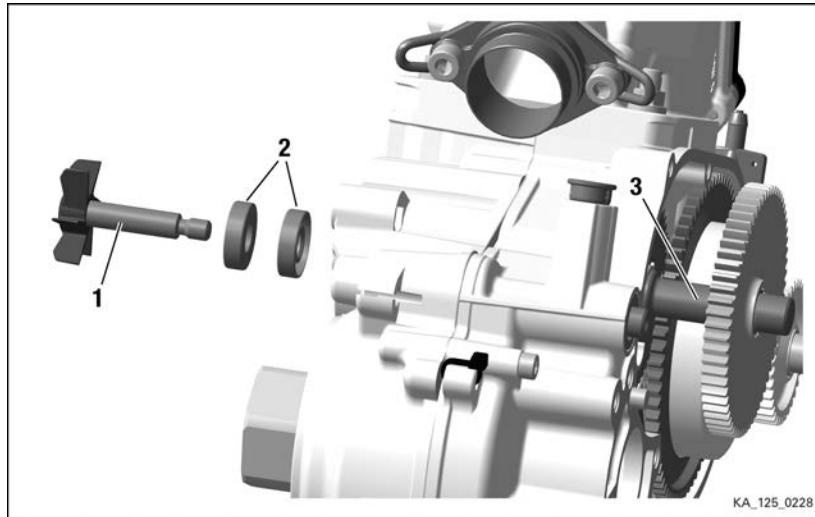

Figure 8.5: Water pump shaft

1 *Water pump shaft*

2 *Oil seal A 10x26x7*

3 *Primary shaft*

BRP-Rotax REPAIR MANUAL

INSPECTION OF COOLING SYSTEM

RADIATOR – INSPECTION OF COMPONENTS

Instruction See [Figure: Radiator](#).

NOTE

If some of the cooling fins are slightly bent, they may be gently bent back into shape.

1. Use compressed air to remove dirt from the cooling fins of the radiator. Never use a high-pressure cleaner.
2. Visual check of the radiator assy. for any cracks or other damage.
3. Check that the radiator cap gasket is in perfect condition.
4. Check the cooling water hoses for porosity and leakage.
5. Check the radiator's windshield for cracks and damage (visual check).
6. Check the rubber buffers for wear and cracks.

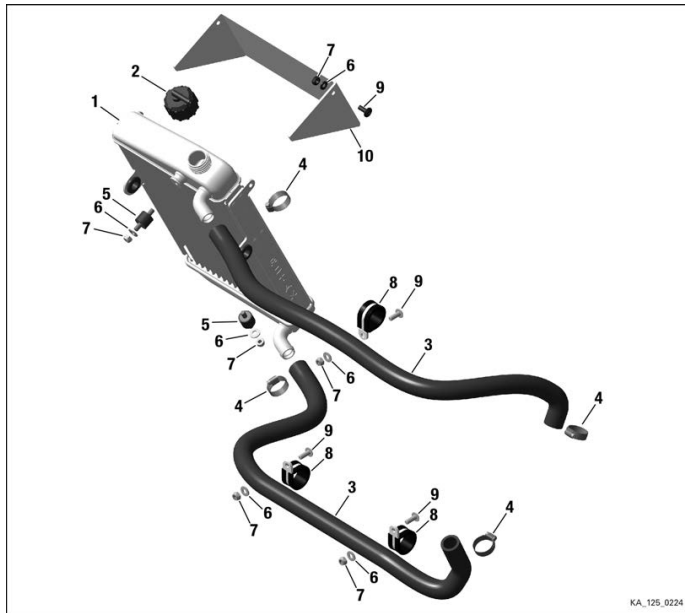

Figure 8.6: Radiator

- | | |
|----------------------------|----------------------------|
| 1 Radiator | 2 Radiator cap with gasket |
| 3 Cooling water hose NW 18 | 4 Clamp 16–25 |
| 5 Rubber buffer 18x15xM6 | 6 Washer 6.4 |
| 7 Lock nut M6 | 8 Cable clamp 26/M6 |
| 9 Allen screw M6x16 | 10 Windshield |

BRP-Rotax REPAIR MANUAL

INSPECTION OF WATER PUMP SHAFT

Instruction See [Figure: Water pump shaft](#).

1. Check the water pump shaft in the areas around the two shaft seal rings; if it is excessively worn it must be replaced.
2. Check the impeller for damage and/or any abnormal deformation, and replace it if necessary.

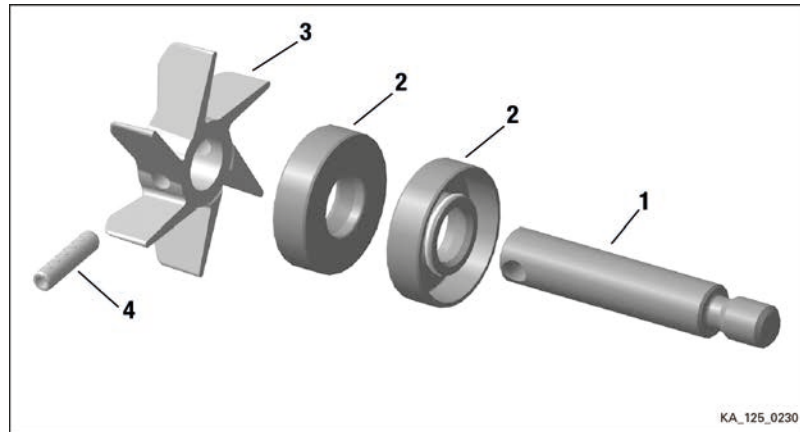

Figure 8.7: Water pump shaft

1 *Water pump shaft*

2 *Oil seal A 10x26/7*

3 *Impeller*

4 *Dowel 4x16*

BRP-Rotax
REPAIR MANUAL

INSTALLING THE RADIATOR

INSTALLATION OF RADIATOR WITH CAP ASSY.

Instruction See [Figure: Radiator](#).

1. Secure the radiator with cap assy. to the kart frame with 3 rubber buffers (5), windshield (10) with Allen screws (9) and washers using lock nuts M6 (7). Tightening torque 10 Nm.

NOTE

Take care to ensure that the radiator is installed in the correct position. New lock nuts must be used. Use washers on the kart frame.

2. Place the cooling water hoses (3) on the sockets on the radiator (4) and align them with the sockets on the engine; then tighten them with the hose clamps (4) to make a watertight connection.
3. Place 3 cable clamps 26/M6 (8) over the radiator hoses (two below, one above) and secure them to the frame with Allen screws w. rounded flange heads (9).
4. Connect the cooling water hoses (3) with the cable clamp 16–25 (4) on the engine.

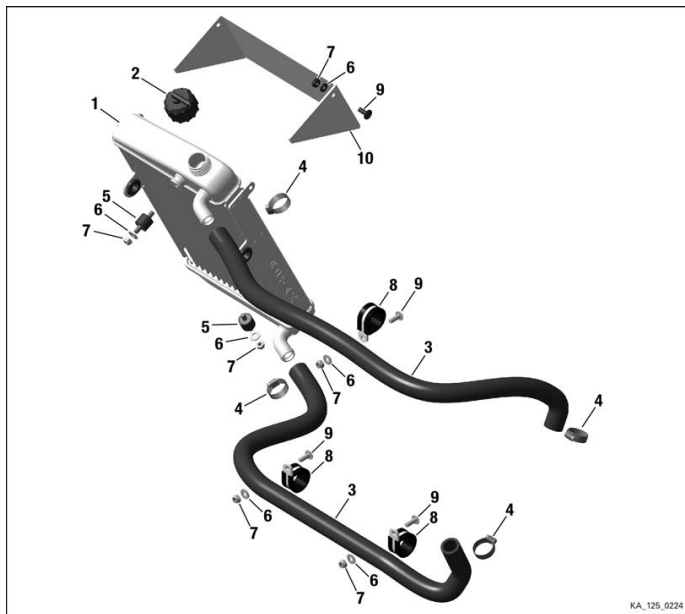

Figure 8.8: Radiator

- | | |
|----------------------------|----------------------------|
| 1 Radiator | 2 Radiator cap with gasket |
| 3 Cooling water hose NW 18 | 4 Cable clamp 16–25 |
| 5 Rubber buffer 18x15xM6 | 6 Washer 6.4 |
| 7 Lock nut M6 | 8 Cable clamp 26/M6 |
| 9 Allen screw M6x16 | 10 Windshield |

INSTALLING THE WATER PUMP SHAFT

REPLACING THE OIL SEALS ON THE WATER PUMP

Instruction See [Figure: Shaft seal ring – water pump](#).

1. Remove the oil seals that need to be replaced from water pump with the insertion jig ROTAX® part no. 676021.
2. Grease the new oil seals with Molycote 111 near the sealing lip and use an insertion jig to press them back in.

NOTE

Take care to install them in the correct position. The hose spring on the outer oil seal must face "outwards", and the hose spring on the inner oil seal should not be visible.

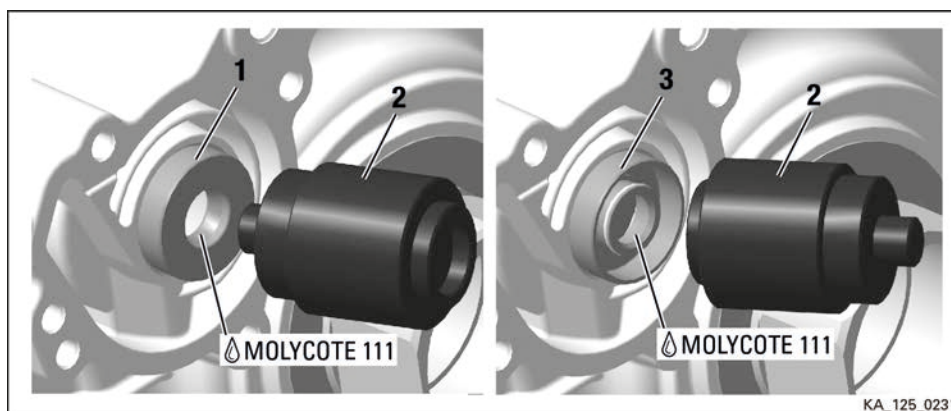

Figure 8.9: Shaft seal ring – water pump

- 1 "Inner" oil seal
- 3 "Outer" oil seal

2 Insertion jig

INSTALLATION OF WATER PUMP SHAFT

Instruction See [Figure: Water pump shaft](#).

1. Secure the impeller of the water pump assy. with spring pin 4x16.

ATTENTION

Water pump shaft has a left hand thread!

2. Fix the water pump shaft (1) to the primary shaft and secure it with LOCTITE 243. Hold up the primary shaft (2) against this movement.

BRP-Rotax REPAIR MANUAL

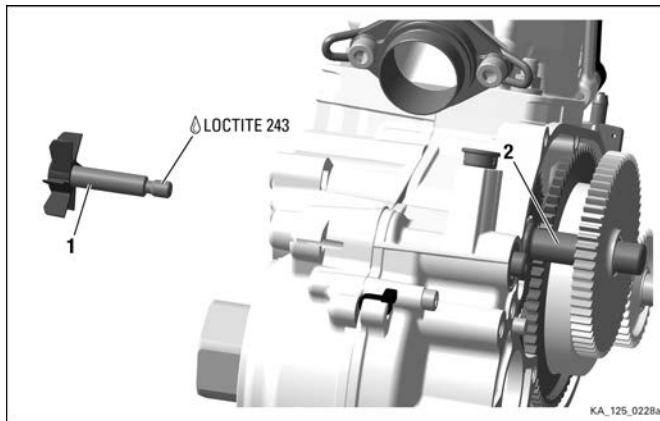

Figure 8.10: Water pump shaft

1 *Water pump shaft*

2 *Primary shaft*

Instruction

See [Figure: Water pump housing](#).

3. Secure the water pump housing (2) and rubber ring (3) to the housing using 4 TAPTITE screws M6x20 (1) and tighten to 7 Nm.

NOTE

Use only the special TAPTITE screws as specified. These are self-tapping. Other types of screw may destroy the threads in the housing, thus resulting in leaks.

4. Assemble the cooling water hose.

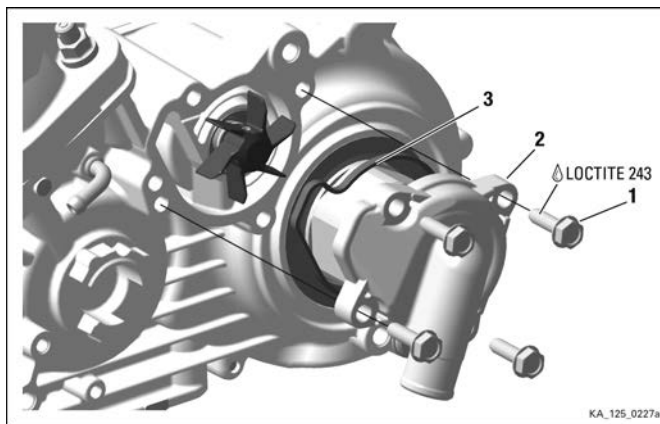

Figure 8.11: Water pump housing

1 *TAPTITE screw M6x20*

2 *Water pump housing*

3 *Rubber ring 61.5x1.5x3.5*

BRP-Rotax
REPAIR MANUAL

FINAL TASKS

Instructions

1. Using a funnel, pour the specified amount of coolant into the filling opening of the radiator.
2. Close the radiator cap.
3. Check that the cooling system is leak-free by warming up the engine.
4. Add some more coolant if necessary.

BRP-Rotax
REPAIR MANUAL

NOTES

BRP-Rotax
REPAIR MANUAL

Chapter: Chapter 9
EXHAUST SYSTEM

TOPICS IN THIS CHAPTER

System description	2
Removal of the exhaust system.....	3
Checking the exhaust system	4
Disassembling the exhaust system	4
Assembling the exhaust system.....	4
Installation of the exhaust system	5

Contents This chapter describes the removal and installation of the exhaust system module of the ROTAX® 125 MAX DD2 evo engine. The description is divided into sections.

BRP-Rotax
REPAIR MANUAL

SYSTEM DESCRIPTION

Overview

Exhaust system

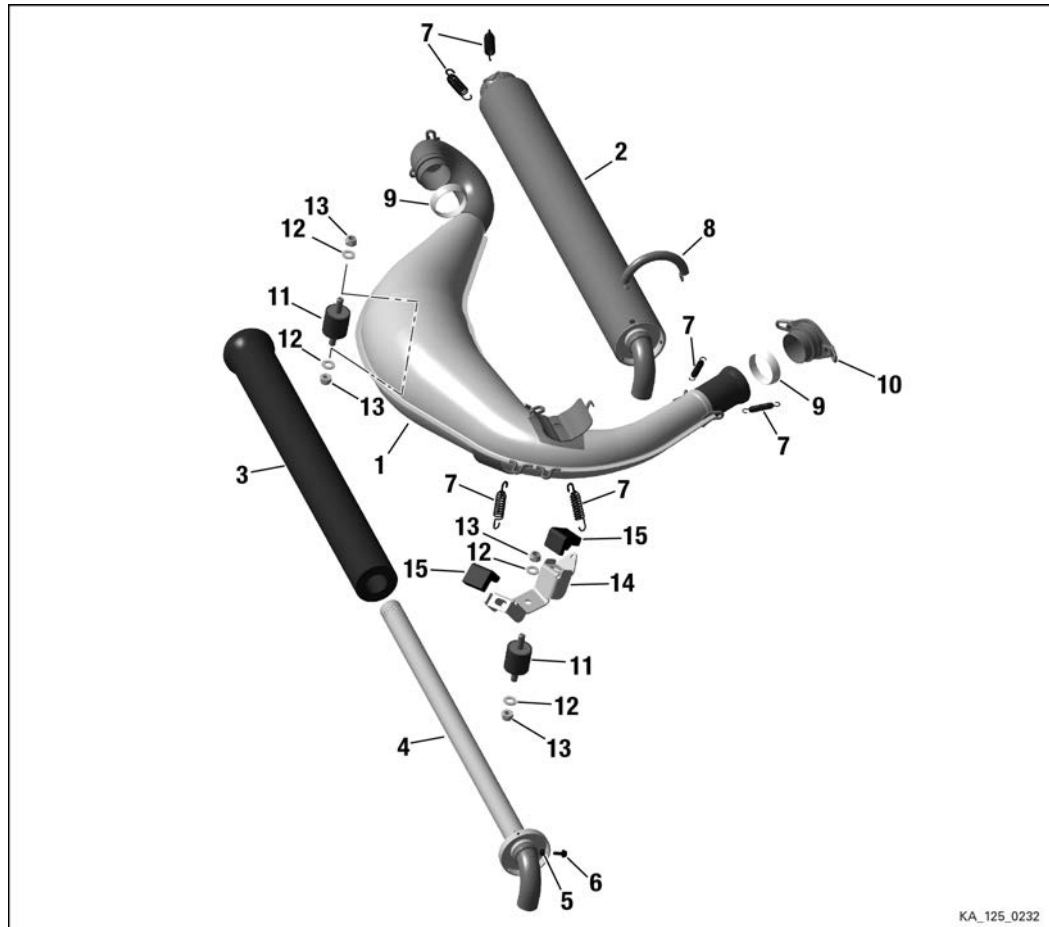

Figure 9.1

1	Exhaust muffer assy.	2	Silencer assy.	3	Isolating mat
4	Perforated tube assy.	5	Lock nut M4	6	Allen screw M4x12
7	Spring stainless	8	Tension spring	9	Exhaust gasket
10	Exhaust socket assy.	11	Rubber buffer	12	Washer 8.4
13	Lock nut M8	14	Retaining plate	15	Rubber buffer

REMOVAL OF THE EXHAUST SYSTEM

Safety instructions

⚠ WARNING

Danger of severe burns and scalds! Always allow the engine to cool down to ambient temperature before starting any work.

Special tools

The following special tools and equipment are required:

Part no.	Description	Field of application
251680	Spring hook	Tension spring

Instruction

Proceeds follows to dismantle the exhaust system:

1. Disconnect tension springs (3) with spring hooks from the exhaust socket (2).
2. Loosen the nuts M8 with washer on the rubber buffer and remove the exhaust system.
3. Take care about the exhaust gasket between exhaust socket and exhaust, replace if worn out.

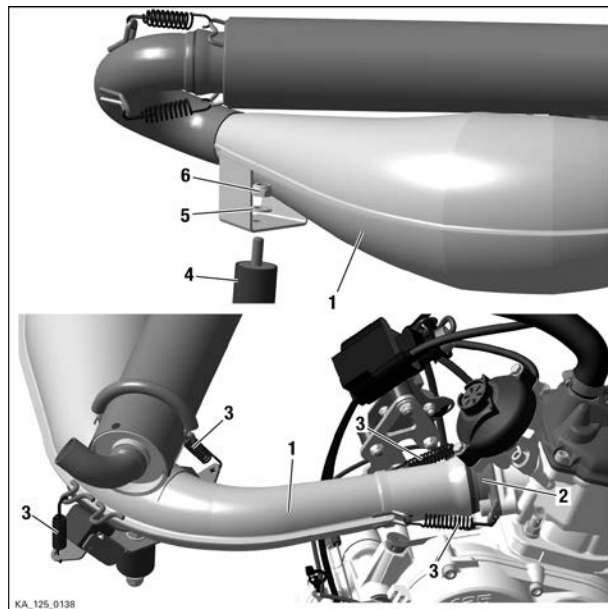

Figure 9.2

- | | |
|------------------------|--------------------------|
| 1 Exhaust muffer assy. | 2 Exhaust socket assy. |
| 3 Spring | 4 Rubber buffer 30x30xM8 |
| 5 Washer 8.4 | 6 Lock nut M8 |

BRP-Rotax REPAIR MANUAL

CHECKING THE EXHAUST SYSTEM

ATTENTION

A worn isolating mat has a major engine damage as result!

Instructions See Figure

1. Check exhaust system for cracks, bending or other damages. Replace if necessary.
2. Clean the ball socket of combustion residue and inspect for wear.
3. Check that the cover rivets are tightly seated.
4. Check exhaust gasket for cracks and inspect for wear. Replace if necessary.
5. Check rubber buffer for cracks and inspect for wear. Replace if necessary.
6. Check the retaining plate for cracks and inspect for wear.

DISASSEMBLING THE EXHAUST SYSTEM

General **NOTE**

If the exhaust system noise increases, then the silencer baffle mat should be replaced.

Instructions See [Figure: Exhaust system](#).

1. Disassembly the exhaust muffler assy. and the silencer assy. Using the exhaust springs tool (part no .251680), remove exhaust springs. Remove the exhaust gasket.
2. Remove hex. collar screw M4x12 with lock nut from the silencer assy.
3. Remove old isolating mat.

ASSEMBLING THE EXHAUST SYSTEM

Instructions See [Figure: Exhaust system](#).

1. Roll up new isolating mat (3) on the inside silencer assy. (2).
2. Put both into the exhaust system.
3. Install cover with Allen screw M4x12 (6) and new lock nut M4 (5).
4. Install a new exhaust gasket (7).
5. Make sure front exhaust pipe end is properly aligned inside ball socket. Install 3 exhaust spring (8)

BRP-Rotax REPAIR MANUAL

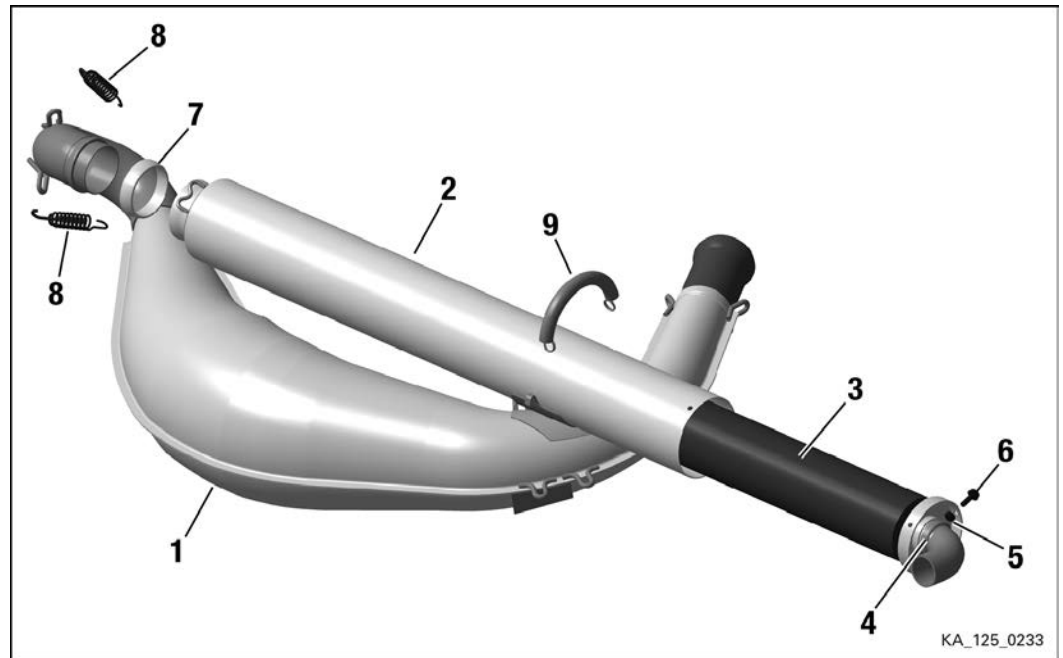

Figure 9.3: Exhaust system

- | | |
|-------------------------|-------------------------|
| 1 Exhaust muffler assy. | 2 Silencer assy. |
| 3 Isolating mat | 4 Perforated tube assy. |
| 5 Lock nut M4 | 6 Allen screw M4x12 |
| 7 Exhaust gasket | 8 Spring stainless |
| 9 Tension spring | |

INSTALLATION OF THE EXHAUST SYSTEM

Instructions

For installation of the exhaust system, see latest Installation Manual for the engine type 125 MAX DD2 evo.

BRP-Rotax
REPAIR MANUAL

NOTES

BRP-Rotax REPAIR MANUAL

Index

A

abbreviations	3
Assembling the exhaust system	4
Assembly of carburetor	11
Assembly of float housing	11
Assembly of housing halves	29
Assembly of intake silencer	12
Authorized personnel	3

C

Carburetor and intake silencer – inspection of components	8
Centrifugal clutch assy. – inspection	10
Check bearings	23
Check the thrust washers, O-rings and needle cage	10
Checking the exhaust system	4
combustion chamber insert installation	29
Consumable materials	6
Crank case assembly	22
Crankshaft assembly	16
Crankshaft not in specification	15
cylinder components inspection	11
cylinder components installation	21
Cylinder installation	25
Cylinder removal	3

D

Disassembling crankcase	6
Disassembling of the crankshaft	9
Disassembling the cylinder	5
Disassembling the exhaust system	4
Disassembly of the carburetor	5
Disassembly of the intake silencer	7
Drain oil	4

E

Engage the secondary gear with the teeth on the primary shaft	20
Exhaust valve, gasket, valve rod housing	22
Exhaust valve, piston	22

F

Filling the gear housing with oil	21
Final tasks	13

G

General note	2
--------------------	---

I

Inspection and adjustment of squish gap	31
Inspection of clutch and starter gear	12
Inspection of clutch drum	10
Inspection of cooling system	8
Inspection of crankshaft	13
Inspection of cylinder components	11
Inspection of exhaust valve	20
Inspection of gears	12
Inspection of intake silencer	9
Inspection of piston and piston ring	12
Inspection of starter reduction gear	11
Inspection of the carburetor	8
Inspection of the carburetor flange and reed valve	19
Inspection of the combustion chamber insert	17
Inspection of the cylinder head cover	17
Inspection of the exhaust socket	18
Inspection of the fuel pump	9
Inspection of the gear wheels	21
Inspection of the housing halves	20
Inspection of the spark plug	15
Inspection of water pump shaft	9
Installation of balance gear	15
Installation of balance gear, starter gear and clutch plate	15
Installation of bearing and oil seal for shaft	22
Installation of clutch drum and secondary gear	18
Installation of clutch plate	17
Installation of crank case assy.	30
Installation of cylinder head cover	29
Installation of exhaust valve	21
Installation of fuel pump, carburetor	13
Installation of piston	24
Installation of radiator with cap assy.	10
Installation of spark plug	34
Installation of starter gear	16
Installation of starter reduction gear	14

BRP-Rotax REPAIR MANUAL

Installation of the carburetor flange and reed valve	27	Removal of the combustion chamber insert	6
Installation of the crankshaft repair kit	9	Removal of the crankcase	5
Installation of the engine on kart chassis	13	Removal of the cylinder head cover	5
Installation of the exhaust socket	26	Removal of the engine from kart chassis	10
Installation of the exhaust system	5	Removal of the exhaust socket	7–8
Installation of water pump shaft	11	Removal of the exhaust system	6, 3
Installation or Replace sealings	23	Removal of the fuel line	7
Installing of shaft and gears	27	Removal of the fuel pump	5
Installing the carburetor and intake silencer	11	Removal of the ignition system	3
Installing the radiator	10	Removal of the overload clutch	8
Installing the water pump shaft	11	Removal of the piston	10
Instruction	5	Removal of the shift mechanism	9
INTRO	1	Removal of the spark plug	5
		Removal of the thermostat	6
		Removal of water pump shaft	6
		Removing the engine from the trestle mounting plate	13
P		Replace of bearing	24
Piston and cylinder sizing	14	Replacing the oil seals on the water pump	11
Piston diameter	13		
Piston pin, circlip	15	S	
Process advice	4	Safety	4
		Safety notice	4
		Special tools	8
R			
Radiator – inspection of components	8	T	
Removal of centrifugal clutch, primary and balance drive	5	Technical data	7
Removal of radiator	4		
Removal of radiator with cap assy	6, 4	U	
Removal of the Bowden cable	8	Use for intended purpose	6
Removal of the carburetor and intake silencer	3		
Removal of the carburetor flange and reed valve	8		
Removal of the carburetor, intake silencer	3		
Removal of the centrifugal clutch assy	4		
Removal of the clutch assy	14		

ROTAX[®]
KARTING

